

# KEYSTONE<sup>®</sup> DESIGN MANUAL & KEYWALL<sup>®</sup>PRO OPERATING GUIDE

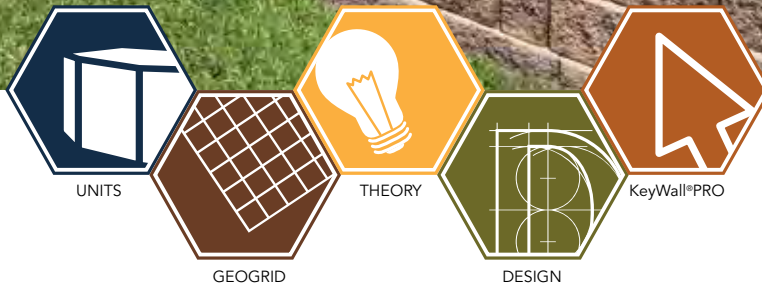

KeyWall<sup>®</sup>PRO

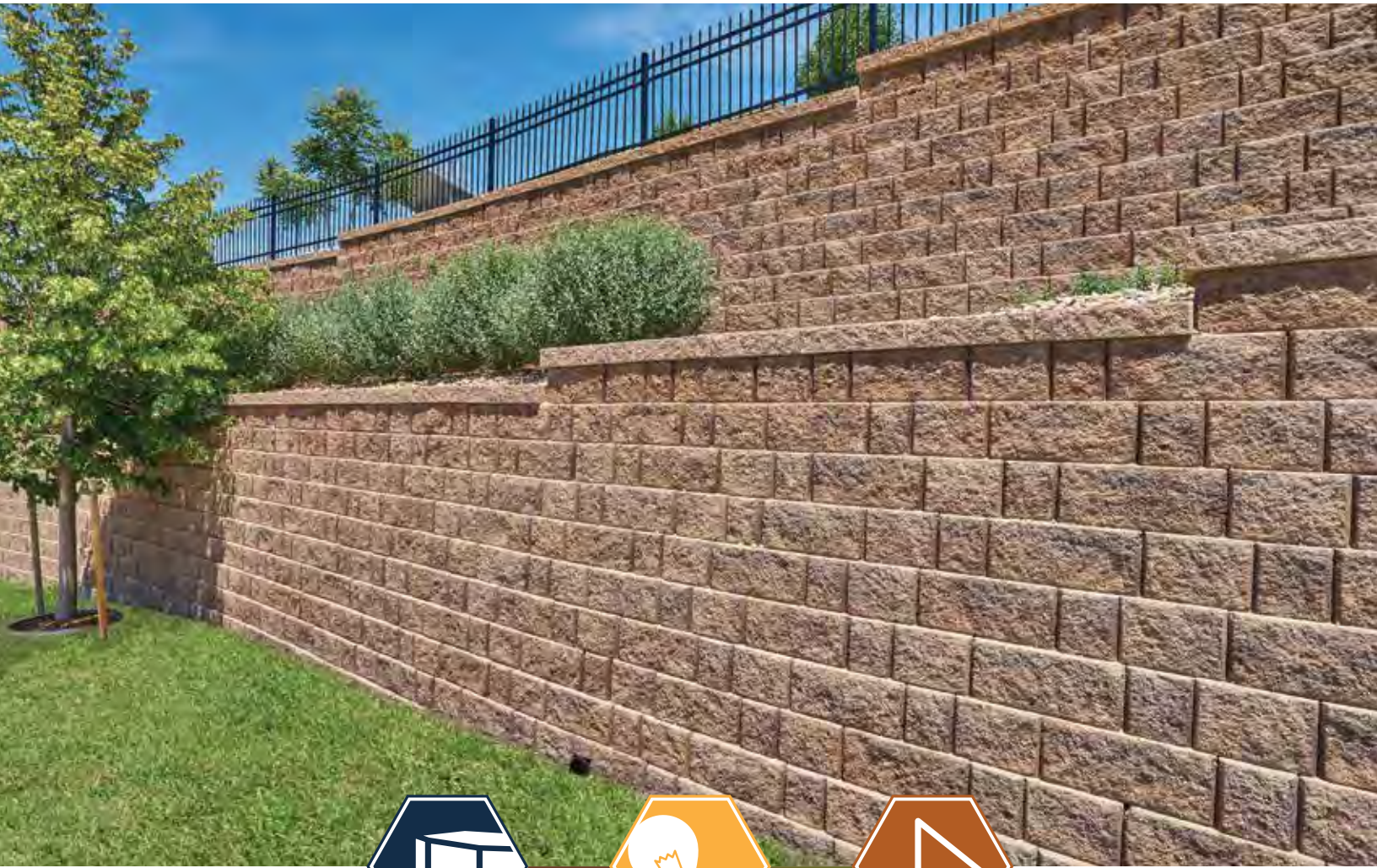

# KEYSTONE<sup>®</sup> DESIGN MANUAL & KEYWALL<sup>®</sup> PRO OPERATING GUIDE

*The information presented in this manual, including technical and engineering data, figures, tables, drawings, and procedures, is provided for general information only. While every effort has been made to ensure accuracy, this information should not be used or relied upon for any specific application without independent professional examination and verification of its accuracy, suitability, and applicability. Anyone using this material assumes any and all liability resulting from such use. Keystone Retaining Wall Systems disclaims any and all express or implied warranties of merchantability fitness for any general or particular purpose or freedom from infringement of any patent, trademark, or copyright in regard to the information or products contained or referred to herein. Nothing herein contained shall be construed as granting a license, express or implied, under any patents. Keystone is a registered trademark of Keystone Retaining Wall Systems LLC. Keystone Retaining Wall Systems are covered by one or more U.S. Patents. Copyright © 1993, 1994, 1995, 2001, 2011, 2020 by Keystone Retaining Wall Systems LLC. Printed in the United States.*

# KEYSTONE<sup>®</sup> DESIGN MANUAL & KEYWALL<sup>®</sup>PRO OPERATING GUIDE



Keystone Retaining Wall Units



Geosynthetic Soil Reinforcement



Retaining Wall Design Theory



The Design Process



KeyWall<sup>®</sup>PRO Operating Instructions



Appendices



**INTRODUCTION**

Table of Contents

# TABLE OF CONTENTS



Introduction..... iv  
 Design Manual & KeyWall®PRO Operating Guide ..... v  
 Geotechnical Responsibility..... vi  
 References ..... vii



**PART ONE | Keystone Retaining Wall Units**

Keystone Retaining Wall Units ..... 1.1  
 Keystone Materials ..... 1.2  
**Pinned Units**  
 Keystone Standard® Unit ..... 1.2  
 Keystone Compac® Unit..... 1.3  
**Lip/Lug Units**  
 Regal Stone Pro®..... 1.3  
 Broadstone® ..... 1.3  
 Valera® ..... 1.4  
 Unit Shear Resistance ..... 1.4  
 Base Shear Resistance ..... 1.4  
 Inter-Unit Shear Resistance..... 1.4-1.5  
 Shear Data & Analysis ..... 1.5  
 Typical Shear Resistance Between Units..... 1.6



**PART TWO | Geosynthetic Soil Reinforcement**

Geosynthetic Soil Reinforcement..... 2.1  
 Design Strength..... 2.2  
 Reduction Factors ..... 2.3  
 Connection Strength..... 2.4-2.5  
 Geosynthetic Soil Interaction Coefficient..... 2.5-2.6  
 Geogrid Manufacturers' Data ..... 2.6



**PART THREE | Retaining Wall Design Theory**

Retaining Wall Design Theory ..... 3.1  
 Important Technical Definitions ..... 3.2  
 Lateral Earth Pressure Theories..... 3.3  
 Coulomb Earth Pressure Theory..... 3.4  
 Coulomb Earth Pressure Equation ..... 3.4-3.5  
 Coulomb Failure Plane Location..... 3.6  
 Rankine Earth Pressure Theory ..... 3.6  
 Rankine Earth Pressure Equations ..... 3.6-3.7  
 Rankine Failure Plane Location ..... 3.7  
 Trial Wedge Analysis..... 3.8  
 Bearing Capacity ..... 3.9  
 Applied Bearing Pressure ..... 3.9  
 Calculated Bearing Capacity ..... 3.10  
 Bearing Capacity Factors ..... 3.10-3.11  
 Settlement..... 3.11  
 Global Stability ..... 3.12  
 Internal Compound Stability..... 3.12-3.13  
 Seismic Analysis ..... 3.14



# TABLE OF CONTENTS



## **PART FOUR** | The Design Process

Introduction .....	4.1
Design Methodology.....	4.2
Unit Selection.....	4.2
Wall Batter .....	4.3
Wall Geometry .....	4.3
Wall Embedment.....	4.4
Sloping Toe.....	4.4
Soil Properties.....	4.5
No-Fines Concrete Backfill .....	4.6
Surcharge.....	4.6
Reinforcement Type & Properties .....	4.7
Soil Reinforcement Length.....	4.7
External Stability Analysis.....	4.8
Battered Wall Design Options .....	4.9
AASHTO LRFD.....	4.9-4.10
Sliding Analysis.....	4.11
Coulomb - NCMA - Sliding .....	4.12
Rankine - AASHTO - Sliding.....	4.12-4.13
Overturning Analysis .....	4.14
Coulomb - NCMA Overturning .....	4.15
Rankine - AASHTO Overturning.....	4.15
Overturning .....	4.15
Bearing Capacity .....	4.15
Ultimate Bearing Capacity .....	4.16
Internal Stability.....	4.16
Tensile Capacity .....	4.17
Tension Level Calculation .....	4.18
AASHTO Internal Tension.....	4.19
Connection Capacity.....	4.19
Pullout Capacity .....	4.20-4.21
Stability of Facing .....	4.21



## **PART FIVE** | KeyWall®PRO Operating Instructions

Installation & User's Guide .....	5.1
KeyWall®PRO Installation .....	5.2-5.4
Launching the KeyWall®PRO Program.....	5.4-5.5
Registration .....	5.6-5.9
KeyWall®PRO Windows Interface .....	5.10-5.18



# TABLE OF CONTENTS



## PART FIVE | KeyWall®PRO Operating Instructions *(continued)*

Project Screen .....	5.18-5.19
Design Criteria Tab.....	5.20-5.21
Wall Unit Tab.....	5.22
Reinforcement Tab.....	5.23
Soil Conditions Tab.....	5.24
Extreme Events Tab.....	5.25-5.26
Stations Tab.....	5.26-5.27
Panels Tab.....	5.28-5.29
Loading Conditions Tab.....	5.29-5.30
Design Tab (Full Wall Design).....	5.30-5.34
Design Tab (Wall Section Analysis).....	5.34-5.37
Internal Compound Stability Tab .....	5.38
Printing Results.....	5.39-5.41
Export to AutoCad .....	5.42
Importing or Updating Data Files .....	5.43



## PART SIX | Appendices Examples

Appendix A: Infinite Slope Surcharge NCMA 3rd Edition - Coulomb Methodology .....	A.1-A.5
Appendix B: NCMA 3rd Edition - Coulomb Methodology Level Surcharge - 250 psf.....	B.1-B.10
Appendix C: Rankine Methodology Level Surcharge - 250 psf.....	C.1-C.11
Appendix D: 3H:1V Sloping Surcharge AASHTO LRFD Methodology.....	D.1-D.12
Appendix E: AASHTO LRFD Methodology Level Surcharge - 250 psf.....	E.1-E.11

Horizon Six Detention Basin  
Mohave County, Arizona  
Keystone Compac® - Tri-plane  
64,000 square feet

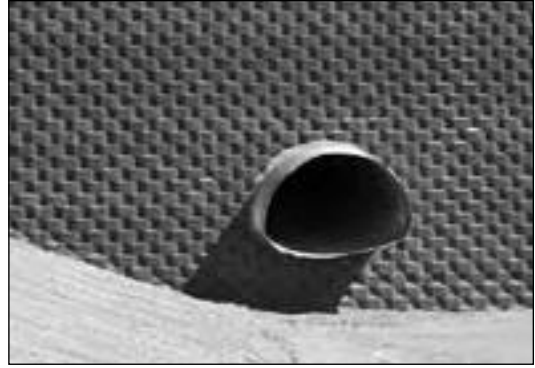



## INTRODUCTION

The Keystone retaining wall system was created to provide an economical, easy-to-install, aesthetically appealing, and structurally sound system as an alternate to boulder, timber tie, concrete panel, or cast-in-place retaining walls. The Keystone system was initially conceived as a gravity wall system that could be constructed to heights of up to 6.5 feet (2 m). The original Keystone Standard unit was 2 feet (600 mm) from face to tail, providing weight and stability to resist the applied earth pressures. Later, the Keystone Compac unit was introduced, a smaller 1-foot (300 mm) deep unit. The units have the stability of a large mass, but are easier to handle, lighter to place, and quicker to install than boulders, crib structures or thin-shelled panel structures. Both units were designed with a structural pin connection and granular interlock, eliminating the need for grouting or mortar. Because of their structural strength with the fiberglass pins and granular drainage fill, the interlocked assembly is more stable than most other structures.

Concurrent with the development of the Keystone system, geosynthetic soil reinforcement was gaining approval and acceptance as a viable soil reinforcement material. The combination of geogrids and Keystone units provided an integrated wall system that could be constructed to heights far exceeding the limits of simple gravity walls. Since 1986, millions of square feet of Keystone retaining walls have been successfully constructed, both as gravity and reinforced systems. Applications vary from residential landscaping walls to structural highway walls, some exceeding 50 feet (15 m) in height.

In 2017, Keystone introduced lip/lug structural units to compliment the current Keystone unit offering. The units include the rear lipped Regal Stone Pro unit and the Broadstone and Valera units which have lug connections. These units are similar in size to Keystone Compac units and also accommodate geosynthetic soil reinforcement.

*Costco Station, Dallas, Texas; Regal Stone Pro® - Straight*







## INTRODUCTION

### Design Manual & Operating Guide

## DESIGN MANUAL & KEYWALL®PRO OPERATING GUIDE

**T**his manual concisely describes the retaining wall design components and related design theory based on accepted engineering principals and concepts discussed in the National Concrete Masonry Association (NCMA) *Design Manual for Segmental Retaining Walls, Third Edition* [Bernardi, et. al, 2009], The American Association of State Highway and Transportation Officials (AASHTO), AASHTO LRFD *Bridge Design Specifications*, and Federal Highway Administration (FHWA) design guidelines. Extensions, additions, or deviations from these methodologies are noted and explained.

It is important for the designer to understand that there are other design methodologies in use in the United States and around the world which will provide different results due to the simplifying design assumptions and methods of calculation utilized. Some use a Coulomb earth pressure analysis like NCMA, others use a Rankine earth pressure analysis. The 7th edition of the AASHTO LRFD Bridge Design Specifications published in 2014 recommends a “simplified” method of design using a load and resistance factor design (LRFD) format. FHWA mandated all retaining walls be designed using LRFD after October 1, 2010. Prior to 2002, an Allowable Stress Design (ASD) approach was specified.

It is our opinion that the NCMA design manual represents a comprehensive approach to segmental retaining wall (SRW) design but tends to conflict in principal with existing methodologies such as those originally developed by the geogrid manufacturers and those contained in AASHTO design guidelines. The NCMA design manual recognizes the many technical nuances of segmental retaining wall design and provides needed criteria for proper engineering and design evaluation of modular systems. The more conservative AASHTO design standards remain the published standard for the transportation sector and cover many of the major structures constructed to date.

KeyWall, Keystone's previous software last updated in 2012, allowed users to design multiple wall sections using different design methodologies. All pertinent data and design criteria were pre-programmed so the designer could focus on the wall geometry, loading conditions, and constructability. The program was easy to understand and the results easy to analyze.

The new KeyWallPRO program has been developed to be more useful to the designer and still simple to use. The designer can choose to design multiple wall sections by choosing "New Wall Section Analysis," similar to the previously offered KeyWall program or they can choose to design the entire wall by choosing "New Full Wall Design." The latter takes user-defined wall profile geometry and will draw, design and compute quantity estimates for multiple walls. It also has the capability to export .dxf CAD files of wall sections and profiles. This manual explains how to use KeyWallPRO to perform both "New Project" options from start to finish.



## GEOTECHNICAL RESPONSIBILITY

**M**ost civil projects designed by professional firms require a subsurface investigation by a qualified geotechnical engineer as part of the site engineering process. The purpose of the investigation is to provide design recommendations for structures that interact with the site soils and to comment on construction considerations for the soils in general.

It is important that the geotechnical investigation and analysis include an assessment of the soil and water conditions in the area of the proposed retaining structures. The appropriate design recommendations should address the following items as they pertain to the retaining structures:

- Bearing capacity of the foundation soils
- Strength properties of the in-situ and proposed fill soils
- Long-term global stability of the structure and adjacent slopes
- Settlement estimates
- Groundwater and subsurface drainage considerations

If this information is not included in the initial soils report, the geotechnical engineer should be contacted to provide the additional information required for the retaining wall design.

The design and successful performance of Keystone retaining wall structures is dependent upon the quality of information obtained by the site investigation. We recommend that all walls of significant size or walls with poor soils and/or steep slopes be evaluated by a geotechnical engineer. For many sites, the geotechnical engineer will be able to provide estimates of the basic design parameters and long-term stability considerations without extensive and expensive testing. For larger structures and more difficult soil conditions, the geotechnical engineer may have to obtain more information about the site soils with additional borings and/or lab tests.

The KeyWallPRO computer-assisted design approach for retaining walls gives the user a sense of simplicity and security in the design of these structures. KeyWallPRO simplifies design to the point that anyone, technically qualified or not, can easily perform an analysis. Although we encourage the responsible use of KeyWallPRO for wall design, we strongly recommend that the final design and site conditions be reviewed by a qualified geotechnical engineer.



## INTRODUCTION

References

## REFERENCES

- American Association of State Highway and Transportation Officials, *AASHTO LRFD Bridge Design Specifications*, 5th Edition, 2010, Washington, DC.
- American Association of State Highway and Transportation Officials, *AASHTO LRFD Bridge Design Specifications*, 7th Edition, 2014 with 2015 Interims, Washington, DC.
- American Society for Testing and Materials, Philadelphia, PA.
- Bowles, J.E., *Foundation Analysis and Design*, 5th ed., McGraw Hill Book Company, N.Y., 1996.
- Federal Highway Administration, *Mechanically Stabilized Earth Walls and Reinforced Soil Slopes, Design and Construction Guidelines*, Report No. FHWA-NHI-00-043, National Highway Institute, Washington, DC, 2001.
- Federal Highway Administration, *Design and Construction of Mechanically Stabilized Earth Walls and Reinforced Soil Slopes*, Report No. FHWA-NHI-10-024, National Highway Institute, Washington, DC, 2009.
- Federal Highway Administration, *Corrosion/Degradation of Soil Reinforcement for MSE Walls and Reinforced Soil Slopes*, Report No. FHWA-NHI-09-087, National Highway Institute, Washington, DC, 2009.
- National Concrete Masonry Association, *Design Manual for Segmental Retaining Walls*, 3rd Edition, 2010 & subsequent minor updates in reprints.

# PART ONE

## KEYSTONE® RETAINING WALL UNITS

*Nordstrom Distribution Center, Elizabethtown, Pennsylvania; Keystone Compac® - Straight Split*

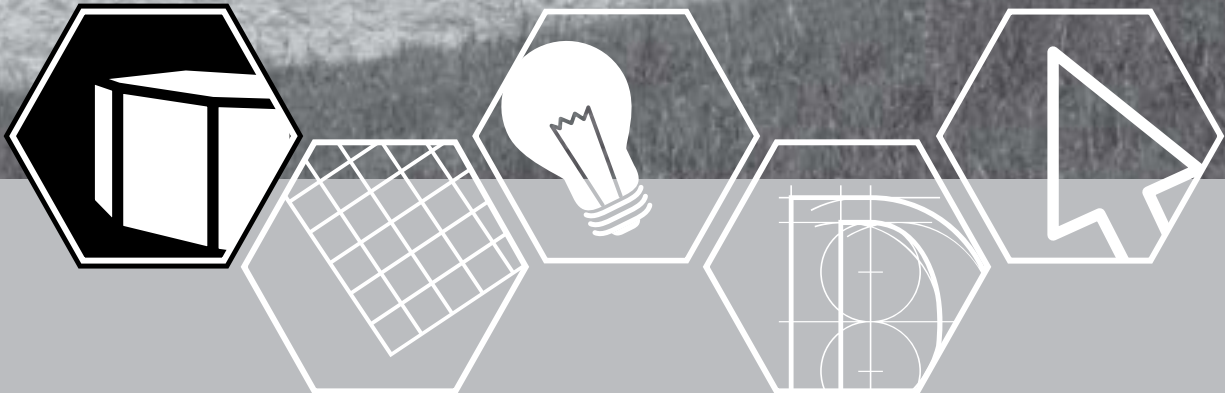
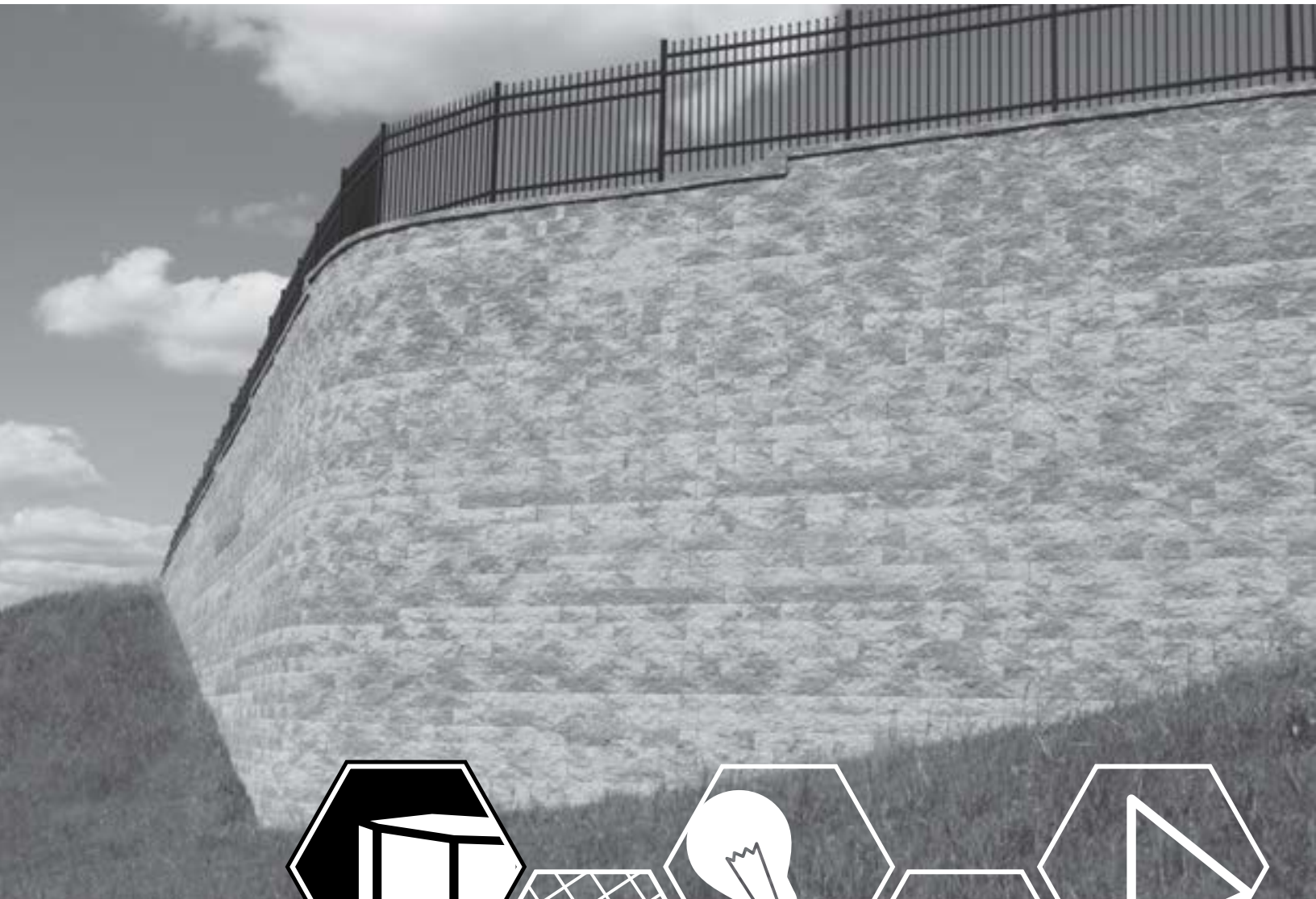



## KEYSTONE RETAINING WALL UNITS

**K**eystone retaining wall units are a zero-slump concrete masonry product developed specifically for use in earth retaining wall structures. Keystone has developed a wide variety of shapes and designs to accommodate most architectural and structural requirements. Local producers of the Keystone products have a variety of colors available, complementing most landscaping and structural retaining wall applications.

Keystone structural products most commonly available include:

### Pinned Units

- Keystone Standard I/Keystone Standard III, Figure 1:1
- Keystone Compac II/Keystone Compac III, Figure 1:2

### Lip/Lug Units

- Regal Stone Pro, Figure 1:3
- Broadstone, Figure 1:4
- Valera, Figure 1:5

Contact your Keystone local producer for additional available units.

The Keystone units listed above are designed for use as structural retaining walls, i.e., those of sufficient height and loadings that require the engagement of a qualified engineer to design the retaining wall structure with appropriate soil reinforcement.

In addition to the above units, Keystone has a complete line of smaller landscape products that are marketed and sold through retail distribution and landscape supply outlets. These products are generally not considered for structural applications and are not discussed further in this manual.

*E7L73 I-75 Off Ramp, Tampa, Florida; Keystone Compac® - Straight Split*





## PART ONE

### Retaining Wall Units

#### Note:

*Not all unit types, face treatments and colors are available at all manufacturing locations. Please check with your local manufacturer or Keystone supplier for availability.*

## KEYSTONE MATERIALS

Keystone units are typically manufactured of concrete with a minimum compressive strength of 3,000 psi (21MPa) at 28 days and a maximum absorption of 8%. All dimensions are plus or minus 1/8 inch (3mm) except for the unit depth, which varies due to the split rock finish. The manufacturing process is automated, so the mixing, compaction, and curing are performed under controlled conditions and provide consistent quality. The units have various face textures available, depending on your local manufacturer.

Keystone Standard and Compac units are vertically interconnected using high-strength pultruded fiberglass pins. The Keystone units have cores that are filled with clean crushed stone to provide additional mechanical interlock and internal drainage. The pins assure a running bond configuration of the units and provide significant lateral connection strength between units. The pins improve the connection between the units and the structural soil reinforcement while assuring proper placement of the reinforcement materials.

The Keystone Standard and Compac units use straight pins which are 5 1/4 inches (133mm) long and 1/2 inch (12.7mm) in diameter. The minimum pin strength is 6,400 psi (44MPa) short beam shear strength and 110,000 psi (750MPa) tensile strength. The pins are manufactured of pultruded fiberglass and will not corrode or deteriorate. In addition, the fiberglass pin does not change properties (soften or become brittle) due to the temperature changes typical in retaining wall applications.

Regal Stone Pro uses a formed rear lip for vertical connection. Broadstone and Valera use a double and single lug respectively to provide shear resistance between units. The lip/lug units have cores and/or form core spaces that are filled with clean, crushed stone for interlock and internal drainage.

## Pinned Units

### KEYSTONE STANDARD® UNIT

The Keystone Standard unit varies due to manufacturing considerations from 18 to 21 inches (457 to 534mm) in depth, with a typical face width of 18 inches (457mm) and height of 8 inches (203mm). The geometry yields exactly 1 square foot (0.09 m<sup>2</sup>) of face area per unit. Units weigh from 95 to 125 pounds (43 to 56kg) each, varying with local manufacturing and aggregates. The centroid of the unit is slightly forward of center toward the face, but for design purposes, it is taken at the center. For design purposes, the in-place density of the aggregate-filled unit is 120 pcf (18.85 kN/m<sup>3</sup>).



Figure 1:1 Keystone Standard I / Keystone Standard III Units

Keystone Standard units are manufactured with a dual pin hole configuration. The front pin setting allows the units to be placed at a minimum setback of approximately 1/8-inch (3.2mm) per 8-inch (203mm) unit height (1° batter, for design purposes use 0°). The rear pin setting allows placement of the units at a minimum 1/4-inch (31.7mm) setback per 8-inch (203mm) unit height (8° batter). An alternate placement of front/back pin hole allows a setback of 5/8-inch (15.9mm) per 8-inch (203mm) unit height (4° batter).



## KEYSTONE COMPAC® UNIT

The Keystone Compac unit is a 12 inch (305mm) deep unit with a typical face width of 18 inches (457mm) by 8 inches (203mm) high. This geometry yields exactly 1 square foot (0.09 m<sup>2</sup>) of face area per unit. Depth may vary from 11 to 12.5 inches (280 to 317mm) depending upon local manufacturing and splitting requirements. Units weigh from 70 to 95 pounds (32 to 43kg) each, varying with local manufacturing and aggregates. For design purposes, the in-place density of the aggregate-filled unit is 120 pcf (18.85 kN/m<sup>3</sup>).



Figure 1:2 Keystone Compac II / Keystone Compac III Units

The dual pin hole configuration allows the same 1° (0° for design purposes), 4°, and 8° setback as the Keystone Standard unit.

## Lip/Lug Units

### REGAL STONE PRO® UNIT

The Regal Stone Pro unit is a 12 inch (305mm) deep unit with an average face width of 18 inches (457mm) by 8 inches (203mm) high (actual width varies dependent on the face style chosen). This geometry yields approximately 1 square foot (0.09m<sup>2</sup>) of face area per unit. Units weigh approximately 80 pounds (36kg), varying with local manufacturing and aggregates. For design purposes, the in-place density of the aggregate filled unit is 120 pcf (18.85 kN/m<sup>3</sup>).



Figure 1:3 Regal Stone Pro Unit

Regal Stone Pro units are manufactured with a rear lip. The rear lip creates a setback of approximately 1 inch (25.4mm) per 8-inch (203mm) unit height (7.1° batter).

### BROADSTONE® UNIT

The Broadstone 8-inch (203mm) is a 12 inch (305mm) deep unit with an average face width of 18 inches (457mm) by 8 inches (203mm) high (actual width varies dependent on the face style chosen). This geometry yields approximately 1 square foot (0.09m<sup>2</sup>) of face area per unit. Units weigh approximately 72 pounds (32kg), varying with local manufacturing and aggregates. For design purposes, the in-place density of the aggregate filled unit is 120 pcf (18.85 kN/m<sup>3</sup>).



Figure 1:4 Broadstone 8-inch Unit

Broadstone 8-inch units are manufactured with a double lug, one on each tail leg. The lugs create a setback of approximately ¼ inch (6.4mm) per 8-inch (203mm) unit height (1.8° batter).



## PART ONE

### Retaining Wall Units

#### VALERA® UNIT

The Valera unit is an 11 inch (279mm) deep unit with an average face width of 18 inches (457mm) by 8 inches (203mm) high (actual width varies dependent on the face style chosen). This geometry yields approximately 1 square foot (0.09m<sup>2</sup>) of face area per unit. Units weigh approximately 93 pounds (42kg), varying with local manufacturing and aggregates. For design purposes, the in-place density of the aggregate-filled unit is 120 pcf (18.85 kN/m<sup>3</sup>).



Figure 1:5 Valera Unit

Valera units are manufactured with a center lug. The center lug creates a setback of approximately  $\frac{1}{6}$  inch (14.3mm) per 8 inches (203mm) of unit height (4.0° batter).

#### UNIT SHEAR RESISTANCE

There are two areas where the shear resistance is important:

- Leveling pad shear resistance
- Inter-unit shear resistance

Both are important to the wall's ability to resist lateral movements during construction and to hold the retained soil in place. The shear and moment capacity of the wall facing prevents bulging of the wall face.

#### BASE SHEAR RESISTANCE

A prepared leveling pad is required to provide a firm, level surface on which to place the base course units at the design elevations and provide localized bearing capacity for the units.

Leveling pads may be constructed of well-compacted gravel/crushed stone or unreinforced concrete. For most walls, the gravel/crushed stone leveling pad is adequate. For taller walls (over 15 feet or 5m), contractors have found that concrete can lead to faster wall installation and is easier to use on the larger projects. The concrete pad requires more care in placement and more expensive materials (concrete versus aggregate), but the speed of placing the first course generally increases.

In Keystone walls with no earth reinforcement (gravity walls), the total resistance of the wall to lateral movement (sliding) is provided by the friction along the base of the units. In soil-reinforced Keystone walls, unit base friction is a lesser component of the sliding calculation as the reinforced zone provides most of the resistance along the base. Since the leveling pad may be constructed of various materials, the frictional resistance varies with the roughness and shear strength of the materials.

#### INTER-UNIT SHEAR RESISTANCE

Laboratory testing has been performed to determine the inter-unit shear resistance of the various Keystone units. The inter-unit shear resistance is the internal shear capacity of the wall facing. Without adequate shear resistance between units, a wall could bulge between layers of reinforcing, shear during construction, or in the case of a gravity wall, shear between any unit above the base.





## INTER-UNIT SHEAR RESISTANCE *(continued)*

For gravity walls, the inter-unit shear capacity is obtained based on the calculated normal force. When a layer of geogrid reinforcing is included in the wall system, the shearing resistance between units may be reduced because the reinforcing can reduce friction between units. The granular interlock is decreased and the unit-to-unit friction may be reduced. For many systems, reinforcing may actually decrease the stability of the face while providing stability to the overall earth mass.

## SHEAR DATA AND ANALYSIS

Inter-unit shear testing (with and without geogrid) has been performed on all Keystone structural units. Testing was initially done at Utah State University on the Keystone Compac and Keystone Standard units. The inter-unit shear testing on the remainder of the units has been completed by Bathurst, Clarabut Geotechnical Testing Inc., NCMA Research & Development Laboratory, SGI Testing Services, LLC, and TRI Environmental. The results of the test for the Keystone Standard III and Keystone Compac III units are graphically depicted in Figures 1:6 and 1:7. Laboratory testing provides the following derived equations for shear resistance based on a total calculated normal force, N, in lbs/lf.

INTER-UNIT SHEAR TABLE

$$N = h W_u \gamma_{\text{unit}}$$

where:

h = Depth to Interface

W<sub>u</sub> = Width of unit face

γ<sub>unit</sub> = Unit weight of unit face

	Unit to Unit	Unit to Unit w/geogrid
Keystone Standard	Minimum 2427	Minimum 1550
	Shear Angle 17.4	Shear Angle 17.4
	Maximum 5506	Maximum 4709
Keystone Standard III	Minimum 1719	Minimum 1500
	Shear Angle 37	Shear Angle 32
	Maximum 4522	Maximum 3984
Keystone Compac II	Minimum 1475	Minimum 1250
	Shear Angle 29	Shear Angle 29
	Maximum 3337	Maximum 3129
Keystone Compac III	Minimum 1393	Minimum 900
	Shear Angle 34	Shear Angle 34
	Maximum 3245	Maximum 2762
Regal Stone Pro	Minimum 1570	Minimum 1260
	Shear Angle 38	Shear Angle 37
	Maximum 4383	Maximum 3973
Broadstone 8"	Minimum 565	Minimum 520
	Shear Angle 38	Shear Angle 37
	Maximum 2909	Maximum 2781
Valera	Minimum 1540	Minimum 1415
	Shear Angle 36	Shear Angle 36
	Maximum 3938	Maximum 3813

To determine metric equivalents in kN/m, divide the minimum and maximum by 68.5. For example, the Keystone Standard unit-to-unit minimum and maximum shear equation would be 35.43 and 80.38, respectively. Shear test reports are available from Keystone.

Additional direct shear tests were completed at Utah State University to evaluate base shear using three types of leveling pad materials. The results of that testing are listed below:

BASE SHEAR TABLE

	Standard	Compac
Crushed Stone Pad	F=995+0.31N	F=0.92N
Concrete Pad	F=205+0.30N	F=0.90N

**Note:**

By default, KeyWallPRO uses a masonry friction reduction factor for design per NCMA versus these base shear equations.



## TYPICAL SHEAR RESISTANCE BETWEEN UNITS

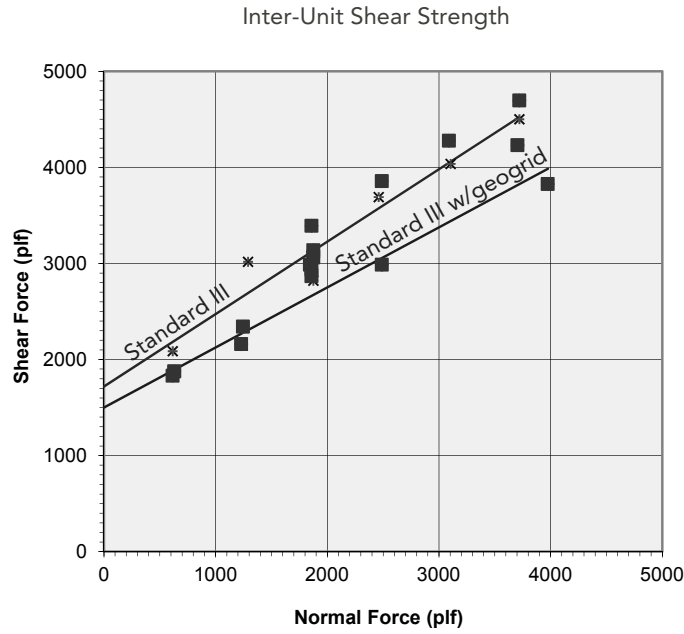

Figure 1:6 Keystone Standard III Unit Inter-unit Shear Strength

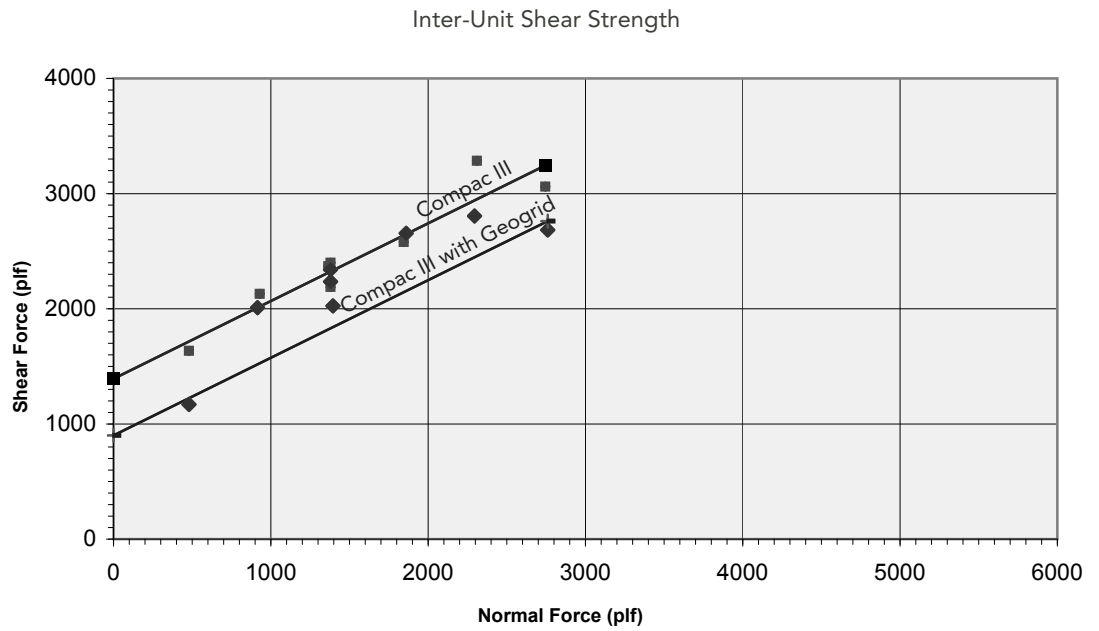
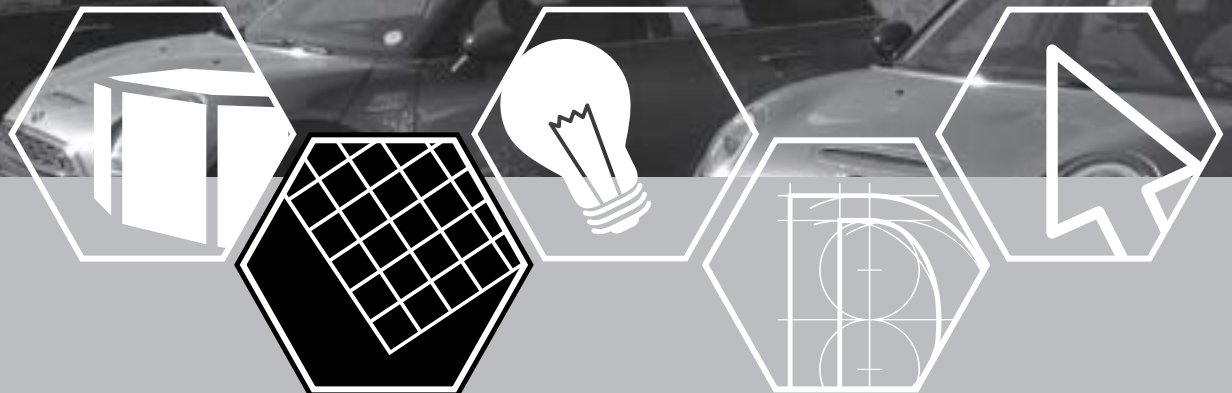
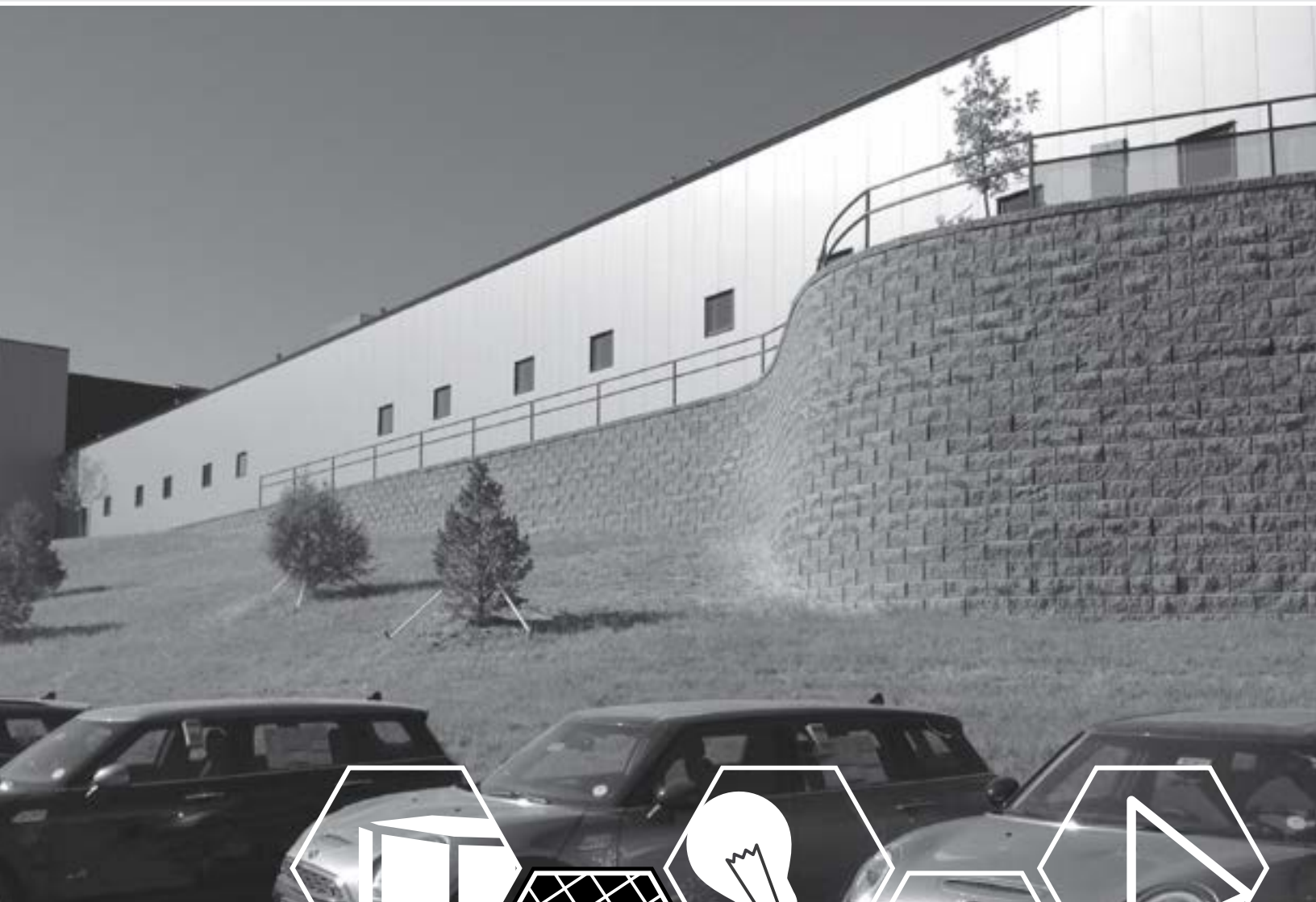

Figure 1:7 Keystone Compac III Unit Inter-unit Shear Strength

# PART TWO

## GEOSYNTHETIC SOIL REINFORCEMENT

*Schomp Mini, Highlands Ranch, Colorado; Keystone Compac® - Victorian*





## GEOSYNTHETIC SOIL REINFORCEMENT

**K**eystone retaining walls may perform as gravity retaining walls for heights up to 6 feet (1.8m) for Keystone Standard units and up to 3.3 feet (1m) for Keystone Compac, Regal Stone Pro, Broadstone and Valera units, depending on geometry, soil type, and specific loading. When a wall exceeds safe gravity heights, soil reinforcement is required to provide stability against overturning and sliding. The majority of Keystone retaining walls are constructed using geosynthetic reinforcement, which is the focus of this manual and the KeyWallPRO program.

Soil-reinforced walls typically consist of geosynthetic materials, primarily geogrids, which are connected to the Keystone units and placed in horizontal layers in the compacted backfill. A limit equilibrium design procedure is used to determine the number, strength, length, and distribution of geosynthetic reinforcement layers required to form a stable soil-reinforced mass.

Geosynthetic material design parameters in the limit equilibrium analysis are:

- Long-Term Design Strength (LTDS) and allowable strength,  $T_{al}$
- Geosynthetic-Keystone unit connection strength,  $T_{cl}$ ,  $T_{sc}$
- Geosynthetic-soil pullout interaction coefficient,  $C_i$
- Geosynthetic-soil direct shear coefficient,  $C_{ds}$

Terminology used to define geosynthetic soil reinforcement tensile strength varies somewhat between authors, specifiers, and suppliers. The terminology used within this section is consistent with that of NCMA and AASHTO/FHWA, unless otherwise noted.

*Wall construction with geogrid reinforcement.*





## PART TWO

### Geosynthetic Soil Reinforcement

## DESIGN STRENGTH

The practice for determining the allowable tensile strength of geosynthetic reinforcement ( $T_{al}$ ), is based upon the U.S. Federal Highway Administration guidelines. This method establishes the Long Term Design Strength (LTDS), be based on sustained load testing, extrapolated to a design life for the structure.

The Long-Term Design Strength (LTDS), for geogrid reinforcement utilized in the Keystone Retaining Wall design is:

$$\text{Equation (2a)} \quad LTDS = T_{ult} / RF_{cr} \times RF_{id} \times RF_d$$

There are two design philosophies currently employed in retaining wall design and analysis. Allowable Stress Design (ASD) is the conventional working stress and factor of safety method of analysis that has been used for years. Limit State Design (LSD) or Load and Resistance Factor Design (LRFD) is the newer method that compares factored loads to factored resistances.

### Allowable Stress Design

The long-term design strength (LTDS), is reduced by an overall safety factor (FS), in Allowable Stress design to account for all factors on loads, uncertainties, etc.

$$\text{Equation (2b)} \quad T_{al} = LTDS / FS$$

### Limit State Design (LRFD)

The Long Term Design Strength (LTDS) is reduced by a resistance factor ( $\phi$ ) in Limit State Design/ (LRFD) to account for material uncertainty.

$$\text{Equation (2c)} \quad T_{al} = \phi_{GEO} LTDS$$

The NCMA and Rankine design methods in KeyWallPRO employ Allowable Stress design procedures. The AASHTO LRFD and Australian AS 4678 design methods in KeyWallPRO employ Limit State design procedures.

### Tensile Strength ( $T_{ult}$ )

$T_{ult}$  is the ultimate strength of geosynthetic reinforcing when tested in a wide width test per ASTM D4595 (geotextile) or D6637 (geogrid). This value is reported as the Mean Average Roll Value (MARV), as determined by the manufacturer's quality control process and accounting for statistical variation.



## REDUCTION FACTORS

### $RF_{cr}$

$RF_{cr}$  is the reduction factor to account for the long-term creep characteristic of polymeric materials. The long-term tension-strain-time behavior of polymeric reinforcement is determined from results of controlled laboratory creep tests conducted on finished-product specimens for periods up to 10,000 hours per ASTM D5262 and D6992. The data is then extrapolated to the project design life of the structure, 75 years or 100 years. Creep rupture testing is similar to the procedure described above, except that, the load at which rupture may occur at the end of the design life is predicted. A combination of 10,000-hour testing and creep rupture testing appears to be the current standard for evaluating geosynthetic material creep. Typical range of  $RF_{cr}$  is 1.4 to 5.0.

### $RF_{id}$

$RF_{id}$  is the reduction factor for installation damage (i.e., cuts, nicks, tears, etc.) created by fill placement and construction equipment operations with various backfill material that can potentially reduce reinforcing strength and performance. The recommended reduction factor for reinforcement installation damage is based on results of full-scale construction damage tests. Site specific values may be determined by performing construction damage tests for the selected geosynthetic material with project specific backfill and equipment. Typical range of  $RF_{id}$  is 1.05 to 2.00.

### $RF_d$

$RF_d$  is the reduction factor to account for the effects of chemical and biological exposure to the reinforcement that are dependent on material composition, including resin type, resin grade, additives, manufacturing process, and final product physical structure. For most soils used with the Keystone System, the manufacturers have included recommended factors to account for possible chemical and biological degradation. In soils where high alkalinity or other aggressive factors (ph < 3 or > 9) may be present, the manufacturer should be contacted for specific recommendations. Typical range of  $RF_d$  is 1.0 to 2.0.

For further information on the chemical and biological durability of a reinforcement, a review of durability is presented in FHWA-NHI-09-087 “Corrosion/Degradation of Soil Reinforcement for MSE Walls and Reinforced Soil Slopes.”

### FS

FS is the overall tension safety factor for material, geometric, and loading uncertainties that cannot be specifically accounted for. FS is similar to other overall safety factors in Allowable Stress design. A minimum factor of safety of 1.5 is required for most permanent applications. For unusual loading conditions, variable or poorly defined soil conditions, this factor may be increased at the discretion of the designer.

### $\phi_{GEO}$

$\phi_{GEO}$  is the geosynthetic resistance factor for material uncertainty used in Limit State Design. The US AASHTO LRFD Code uses 0.90 for the tensile resistance factor. Resistance factors will vary in Limit State Design based on the load/resistance factor system adopted by specific design codes.

#### Note:

*KeyWallPRO permits the choice of four different backfill materials (clays and silts, sands, 3/4- inch (20 mm) gravels or aggregate, and 1-1/2 inch (37 mm) gravels or aggregate), which establish a default value for the installation damage factors used in the LTDS determination, based on the manufacturer’s recommendations and testing.*



## CONNECTION STRENGTH

The connection strength is the strength state reinforcement-facing connection strength. The capacity is dependent upon the vertical depth to the reinforcement, wall geometry, type of Keystone unit utilized, and the specific geosynthetic utilized.

**Note:**  
*Reinforced soil wall designs are unique to the specific Keystone units and geosynthetic reinforcement used. Connection data is specific to each combination and reinforcement level. Substitution of any materials invalidates a given wall design.*

Laboratory testing is required to define the connection strength for specific units and geosynthetic materials at varying normal pressures. Typical graphs for an individual stress-strain test and complete series plot is shown in Figure 2:1 and Figure 2:2 per NCMA Test Method SRWU-1/ASTM D6638.

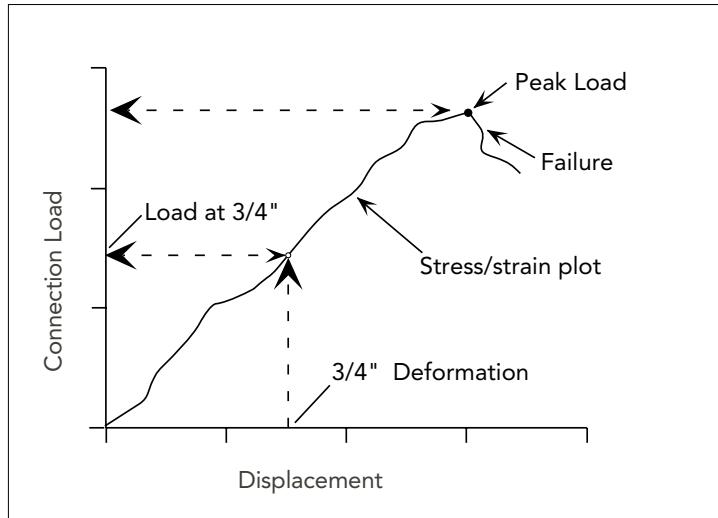

Figure 2:1 Load Test at one Normal Force

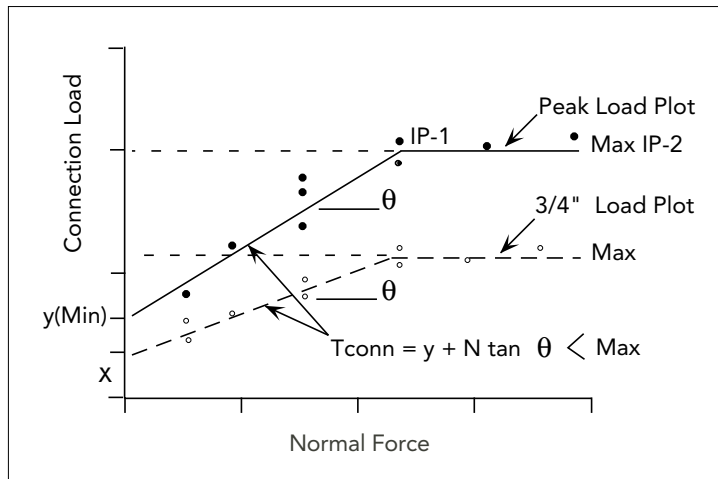

Figure 2:2 Connection Load Plots at Different Normal Forces

**Note:**  
*y(Min): Minimum Connection Capacity*

*IP-1: First Inflection Point*

*IP-2: Second Inflection Point*



## CONNECTION STRENGTH (continued)

In Allowable Stress design, the calculated tensile load at each reinforcement level in the geosynthetic must be less than 1) the allowable geosynthetic design strength,  $T_{al}$ , and 2) an ultimate connection strength limit,  $T_{cl}$ , divided by a safety factor ( $T_{cl}/FS$ ). The recommended minimum factor of safety on the ultimate connection strength is 1.5.

**Equation (2d)**  $T_{cl} = T_{conn} / FS$

RFD design, the factored tensile load at each reinforcement level in the geosynthetic must be less than 1) the allowable geosynthetic design strength,  $T_{al}$ , and 2) the ultimate connection strength limit,  $T_{cl}$ , times the appropriate resistance factor ( $\phi$ ). Using AASHTO LRFD,  $T_{cl}$  is also reduced by the connection creep factor,  $RF_{cn-cr}$ , and durability factor,  $RF_{cn-d}$ .

Serviceability strength,  $T_{sc}$ , is defined as the connection strength at a maximum 0.75-inch (20mm) movement, as determined with the NCMA Test Method SRWU-1/ASTM D6638. Serviceability criteria is only considered when a service state analysis is being performed. In the third edition of the NCMA manual, the serviceability requirement was removed.

**Equation (2e)**  $T_{cl} = \phi_{GEO} \times T_{conn} / CRF_{cn-cr} \times RF_{cn-d}$

**Note:** *AASHTO requires that 1,000-hour sustained load testing be performed on all geosynthetic connection schemes for MSE walls per FHWA guidelines. This testing can result in an additional reduction factor that reduces connection capacity over the life of the structure. There is no evidence that connection creep is a long term performance consideration based on the thousands of walls constructed since the 1980s. NCMA does not recognize the concept in their "Design Manual for Segmental Retaining Walls" and Keystone has not observed this in practice. The most probable explanation is that the "Design" loads never materialize at the connection as extensible reinforcement can "yield" to release any stress build up while the surrounding soil and reinforcement picks up the load (ie, arching). Current US practice is to analyze the connection at 100% of the theoretical design load in the reinforcement, which overstates the load and probably explains the lack of creep-related connection issues.*

## GEOSYNTHETIC-SOIL INTERACTION COEFFICIENT

Two types of soil-reinforcement interaction coefficients or interface shear strength parameters are used for design of soil reinforced structures: pullout interaction coefficient,  $C_i$ , and direct shear coefficient,  $C_{ds}$ .

The pullout interaction coefficient is used in stability analysis to compute the frictional resistance along the reinforcement/soil interface in the zone beyond a defined plane of failure. The calculation yields the capacity to resist pullout of the reinforcement from the soil.

The direct shear coefficient is used to determine the factor of safety against outward sliding of the wall mass along the layers of reinforcement. The coefficients are determined in the laboratory and are a function of soil and geosynthetic material types.

Design pullout resistance of the geosynthetic reinforcement is defined as the ultimate tensile load required to generate movement of the reinforcement through the soil mass measured at a maximum  $\frac{3}{4}$  inch (19 mm) displacement. The recommended minimum factor of safety against geosynthetic pullout is 1.5. Equivalent resistance factors are used in limit state design. ASTM D6706 may be used to determine pullout coefficients for geogrids.





**Note:**  
*These coefficients do not apply to Geotextiles or “fat” soils.*

**Note:**  
*As new materials are developed or new data is provided, KeyWallPRO's data files will be updated. Keystone provides the data as a service to its customers and to ensure data uniformity for Keystone design. This information is provided with no written or implied warranty as to the accuracy of the data supplied. Data values should be verified with the manufacturers.*

## **GEOSYNTHETIC-SOIL INTERACTION COEFFICIENT** (continued)

KeyWallPRO uses the following default values for  $C_i$  and  $C_{ds}$  based upon the reinforced fill material chosen.

<b>Soil Type</b>	<b><math>C_i</math></b>	<b><math>C_d</math></b>
1½" - Gravels or Aggregate	0.9	0.9
¾" - Gravels or Aggregate	0.9	0.9
Sands	0.8	0.8
Clays and Silts	0.7	0.7

Consult geogrid manufacturer for clay-reinforced soil material with an internal friction angle less than 25°.

## **GEOGRID MANUFACTURERS' DATA**

Geogrid manufacturers were contacted during the development of this Keystone Design Manual and asked to provide the required information to evaluate their design parameters. The material provided and testing performed by Keystone is the basis of the data files created for KeyWallPRO. Information provided to Keystone by the geogrid manufacturers/suppliers is available directly from the geogrid manufacturers.

# PART THREE

## RETAINING WALL DESIGN THEORY

*Ironwood at Red Rocks, Littleton, Colorado; Keystone Compac® - Stone Split*

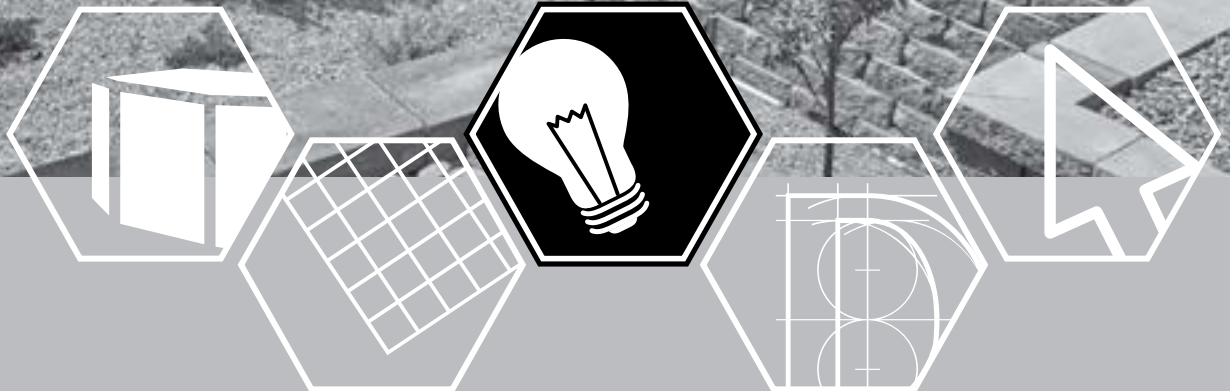
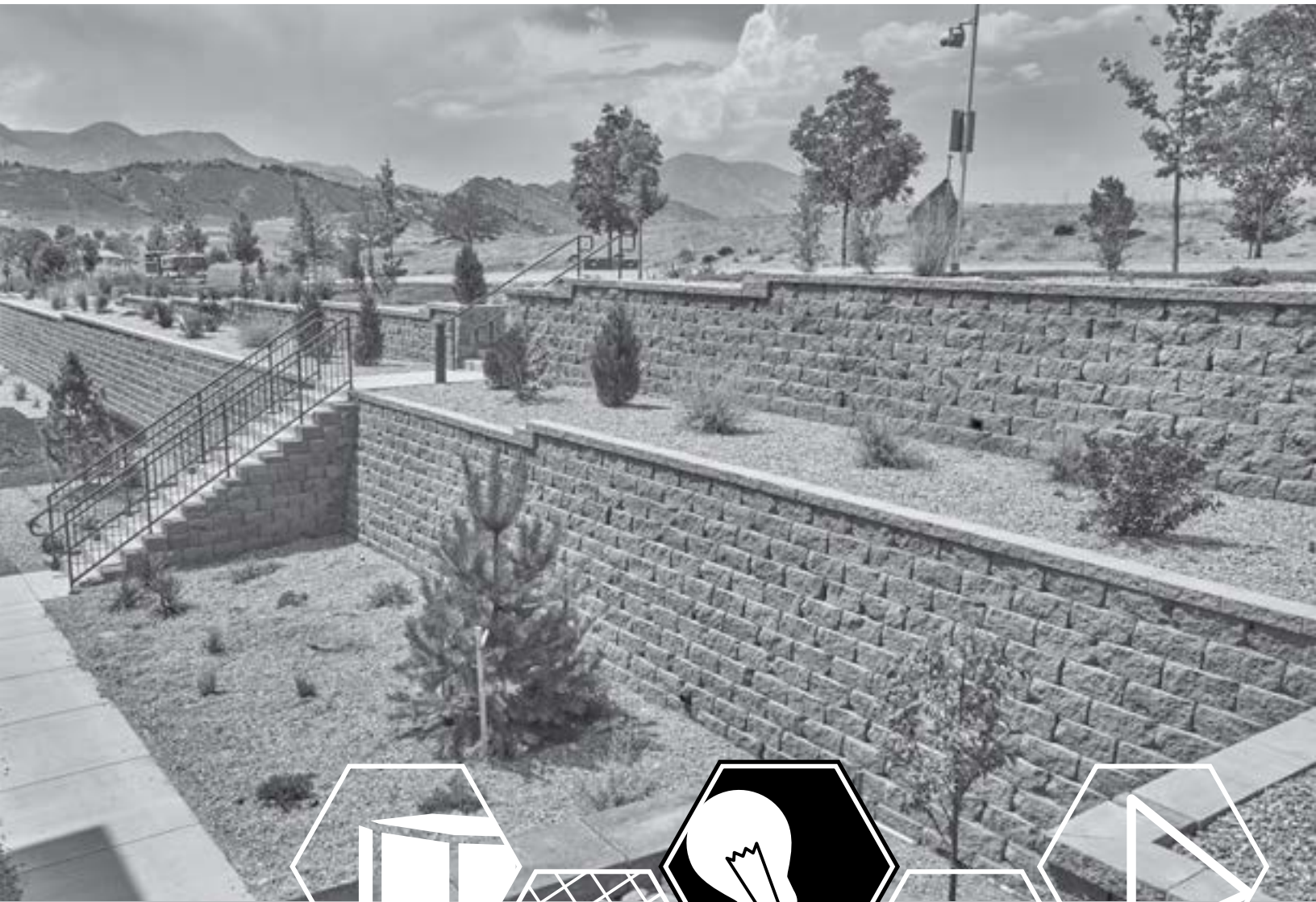



## RETAINING WALL DESIGN THEORY

**E**arth retaining wall structures require three primary areas of design analysis: 1) lateral earth pressures 2) foundation bearing capacity, and 3) global or overall stability. The analysis of each is based on the following engineering properties of the soil(s): angle of internal friction ( $\phi$ ), soil cohesion ( $c$ ), and the density ( $\gamma$ ) of the soils.

In this chapter, the basic mechanisms of lateral earth pressures and stability of foundations are presented. Global stability and seismic analysis are beyond the scope of this design manual but a brief description is provided. Once the basic concepts and mechanisms of earth pressures are understood, simplification of the calculations to develop the Coulomb and Rankine earth pressure theories can be examined. There are further simplifications made to the theories when adapted for design of mechanically stabilized earth (MSE) structures. By starting with the basic theory, it is easier to understand the mechanisms of performance and failure and adapt the design to special conditions not directly addressed by the simplified methods.

The user should refer to recent geotechnical textbooks, the NCMA *Design Manual for Segmental Retaining Walls*, FHWA *Design and Construction of Mechanically Stabilized Earth Walls and Slopes*, and AASHTO *Standard Specifications for Highway Bridges*, for additional material and information on soils and MSE structures. This manual is solely intended to provide insight into the KeyWallPRO design software and the general principles of modular wall design without being an exhaustive summary of soil mechanics.

*Hanover Lakes, St. Cloud, Florida; Keystone Compac® - Straight*





## PART THREE

### Retaining Wall Design Theory

## IMPORTANT TECHNICAL DEFINITIONS

### Effective Stress Design

The soil strength parameters are based on drained conditions that are applicable to granular soils and fine grained soils for long term, drained conditions. (Note: these properties are referred to as  $\phi'$  and  $c'$  in most textbooks. In this manual,  $\phi$  and  $c$  will be used for simplicity and represent effective stress analysis.)

### Angle of Internal Friction ( $\phi$ )

This value represents the frictional shear strength of the soil when tested under compacted and confined conditions. This value should not be confused with a soil “angle of repose,” which reflects the angle that a pile of loose soil will naturally stand.

### Peak Strength

The peak shear strength of a soil is the maximum load measured during a test at a nominal displacement. This manual will utilize peak shear strength values in effective stress analysis unless otherwise noted. Residual strength values require greater movement of the soil than is intended by the design of reinforced soil structures but may be appropriate in some cases with cohesive soils.

### Global Stability

Conventional retaining wall design only looks at simple sliding, overturning, and bearing as failure modes. This manual refers to global stability as all other combinations of internal and external stability, slope stability, and compound failure planes that may compromise the wall structure.

### Failure Plane

Soil failure planes are typically non-linear and are often represented by a log-spiral curve. Internally, the failure plane (locus of maximum stress points) is modeled as a straight line following the appropriate Rankine or Coulomb definition of the slope angle for simplification.

### Bearing Capacity Factors

The general bearing capacity formula as proposed by Terzaghi is used. However, different bearing capacity factors have been published by Meyerhof, Hansen, and Vesic over the years. This manual uses the factors proposed by Vesic (1975), which is consistent with the other documents discussing MSE walls. (Note: All factors assume level ground and must be adjusted for sloping ground conditions.)

Soil mechanics text books include sections on passive and active earth pressures. They describe the theories of Coulomb and Rankine and methods of solution via formulas, graphical methods, and computer analysis. This manual will briefly discuss the methods of active earth pressure calculation as it relates to reinforced soil structures and accepted design principals. Passive pressures are typically neglected and not covered in this manual.



## LATERAL EARTH PRESSURE THEORIES

The NCMA *Design Manual for Segmental Retaining Walls, Third edition*, is based on Coulomb earth pressure theory. The basic assumptions for this active wedge theory were developed by Coulomb (1776). The other major methodology is Rankine earth pressure theory (1857), which is based on the state of stress that exists in the retained soil mass. Both theories essentially model the weight of the soil mass sliding along a theoretical plane of failure (Figure 3.2 and 3.3). The lateral earth pressure,  $P_a$ , is the net force required to hold the wedge of soil in place and satisfy equilibrium.

The major difference between the two theories is that the Coulomb model and equations account for friction between the back of the wall and the soil mass as well as wall batter. Rankine equations more conservatively assume no wall friction at the soil-wall interface and a vertical wall structure which greatly simplifies the mathematics of the problem. The friction at the back of the wall face and at the back of the reinforced zone for external stability computations, provides an additional force component that helps support the unstable wedge of soil. Because of these additional resisting forces, the lateral earth pressure calculated by Coulomb is generally less than the earth pressure that would be predicted by the Rankine equations.

AASHTO design methodologies are generally based on applied Rankine earth pressure theory for earth reinforced structures. AASHTO design methodology is required on most transportation-related projects operating under this more conservative design criteria.

**Note:**

*When the backslope is equal to the assumed friction at the back of the wall ( $\beta=\delta$ ), Coulomb and Rankine formulas provide identical earth pressure coefficients and resultant forces for vertical walls.*



## COULOMB EARTH PRESSURE THEORY

The reader should note that for horizontal surfaces (level surcharge) or infinite sloping surfaces (extending beyond the theoretical Coulomb failure plane), a closed-form equation solution is applicable and easily derived. For geometries where the slope changes within the zone of failure (broken back slope), the simple equations are no longer applicable and may be unnecessarily conservative. For example, if a short broken back slope is modeled as an infinite slope, the design may require significantly more reinforcement and excavation than if modeled correctly. For these conditions, the trial wedge method is used in the external analysis and an approximation method used in the internal analysis depending on design methodology. This is an iterative trial wedge process where successive failure surfaces are modeled until a maximum earth pressure force is calculated for the geometry and loading given (See Figure 3:4).

The earth pressure behind the wall face or at the back of the reinforced zone is represented by a triangular pressure distribution for active soil pressure and a rectangular distribution for uniform surcharge pressure as is shown in Figure 3:1.

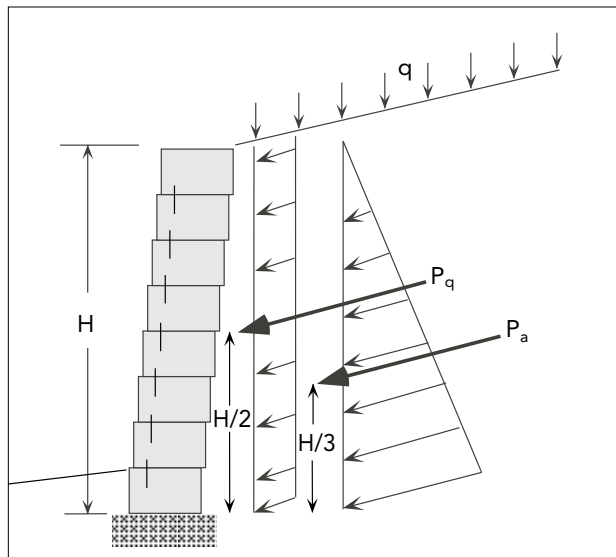

Figure 3:1 Earth Pressure Diagram

## COULOMB EARTH PRESSURE EQUATION

The appropriate Coulomb earth pressure equations for earth and surcharge pressure are as follows:

Equation (3a)  $P_a = \frac{1}{2} \gamma H^2 k_a$

Equation (3b)  $P_q = qHk_a$

where:

$k_a$  = coefficient of active earth pressure

$\gamma$  = moist unit weight of the soil

H = total design height of the wall

q = uniform surcharge



## COULOMB EARTH PRESSURE EQUATION (continued)

The active earth pressure coefficient,  $k_a$ , is determined from an evaluation of the Coulomb wedge geometry shown in Figure 3:2 and results in the following  $k_a$  coefficient:

$$\text{Equation (3c) } k_a = \frac{\sin^2 (\alpha + \phi)}{\sin^2 \alpha \sin (\alpha - \delta) \left[ 1 + \sqrt{\frac{\sin(\phi + \delta) \sin(\phi - \beta)}{\sin(\alpha - \delta) \sin(\alpha + \beta)}} \right]^2}$$

where:

- $\alpha$  = angle of batter from horizontal
- $\phi$  = angle of internal friction of soil
- $\beta$  = slope angle above wall
- $\delta$  = angle of friction at back of wall

This equation is found in differing forms in other texts due to the trigonometric assumptions made in the formula derivation. The derivation of this Coulomb formula can be found in geotechnical textbooks such as *Foundation Analysis and Design* by Bowles (1996).

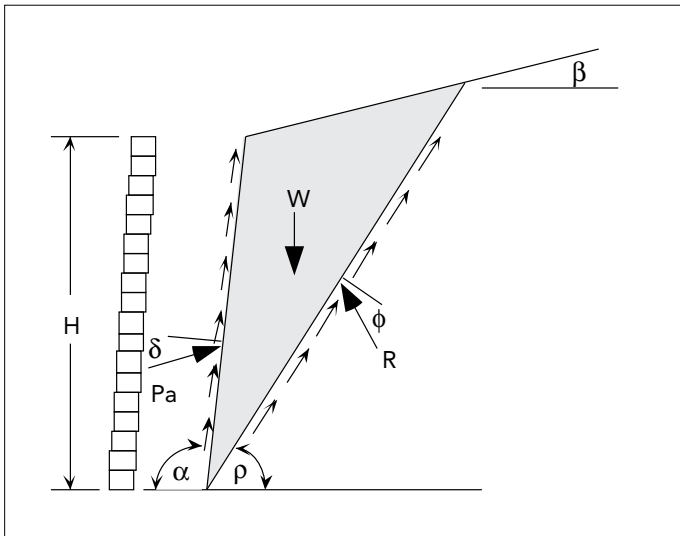

Figure 3:2 Coulomb Wedge Diagram



## PART THREE

### Retaining Wall Design Theory

## COULOMB FAILURE PLANE LOCATION

The Coulomb failure plane varies as a function of the wall geometry and friction angles for both the soils and the soil/wall interface. For level surcharge and infinite slope conditions, the relationship for  $\rho$  is:

$$\text{Equation (3d)} \quad \tan(\rho - \phi) = \frac{-\tan(\phi - \beta) + \sqrt{\tan(\phi - \beta)[\tan(\phi - \beta) + \cot(\phi + \iota)][1 + \tan(\delta - \iota) \cot(\phi + \iota)]}}{1 + \tan(\delta - \iota)[\tan(\phi - \beta) + \cot(\phi + \iota)]}$$

where:

- $\phi$  = angle of internal friction
- $\iota$  = batter of wall measured from vertical ( $\alpha - 90^\circ$ )
- $\beta$  = slope angle above the wall
- $\delta$  = angle of friction at back of wall  
(or reinforced mass)

Tables are available in geotechnical publications that tabulate these values and assist in determining the appropriate Coulomb earth pressure coefficients and failure plane orientation based upon the wall geometry and soil parameters. The KeyWallPRO program calculates these values for each geometry. For broken back conditions, a trial wedge calculation can be used instead of the formulas.

## RANKINE EARTH PRESSURE THEORY

Rankine earth pressure is a state of stress evaluation of the soil behind a retaining structure that traditionally assumes a vertical wall and no friction between the soil/wall interface. The orientation of the resultant earth pressure is parallel to the backslope surface.

## RANKINE EARTH PRESSURE EQUATIONS

The earth pressure behind the wall face or at the back of the reinforced zone is represented by a triangular pressure distribution similar to that shown in Figure 3:1. The earth pressure equations are the same as Coulomb:

$$\text{Equation (3e)} \quad P_a = \frac{1}{2} \gamma H^2 k_a$$

$$\text{Equation (3f)} \quad P_q = qHk_a$$

where:

- $k_a$  = coefficient of active earth pressure
- $\gamma$  = moist unit weight of the soil
- $h$  = total design height of the wall
- $q$  = uniform live load surcharge





## RANKINE EARTH PRESSURE EQUATIONS (continued)

$k_a$  can be determined from an evaluation of the Rankine wedge geometry similar to the Coulomb wedge analysis as shown in Figure 3:3.

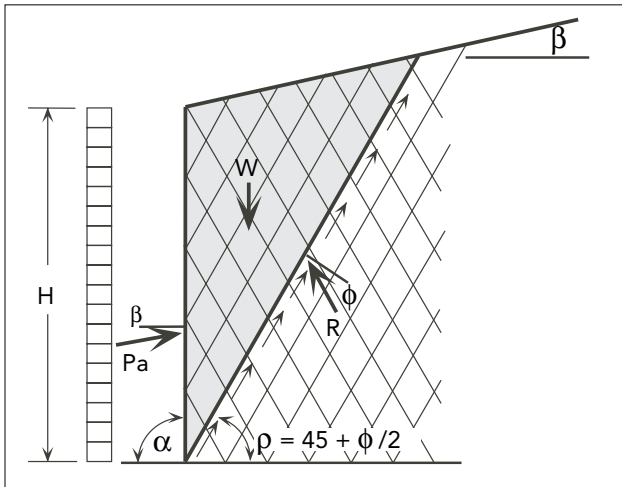

Figure 3:3 Rankine Wedge Diagram

This results in the following equations for  $k_a$ :

- Vertical wall, level backslope

**Equation (3g)**  $k_a = \tan^2 (45 - \phi/2)$

- Vertical wall, backslope

**Equation (3g)**  $k_a = \cos \beta \left[ \frac{\cos \beta - \sqrt{\cos^2 \beta - \cos^2 \phi}}{\cos \beta + \sqrt{\cos^2 \beta - \cos^2 \phi}} \right]$

where:

- $\phi$  = angle of internal friction of soil
- $\beta$  = slope angle above wall

## RANKINE FAILURE PLANE LOCATION

The Rankine failure plane location is typically assumed to be at:

**Equation (3h)**  $\rho = 45^\circ + \phi/2$

Where  $\rho$  is fixed and measured from horizontal under all design scenarios, which is only technically correct for level surcharge applications and minimal wall batter. In theory, the Rankine failure plane varies under backslope conditions. However, it is customary to fix the failure plane at  $45^\circ + \phi/2$  in earth reinforcement design, thus best representing the curved failure surface and locus of maximum stress points for a reinforced soil mass.

### Note:

*The Coulomb earth pressure equation will provide identical Rankine earth pressure coefficients by setting the interface friction angle,  $\delta$ , equal to the backslope,  $\beta$ , for a specific design case. Keystone does not recommend the Rankine design method for battered soil reinforced walls due to the fixed failure plane. Use the NCMA method instead.*



## PART THREE

### Retaining Wall Design Theory

## TRIAL WEDGE ANALYSIS

The limitation of closed form solutions, such as the Coulomb and Rankine equations, is that only simple level and infinite sloping surcharges with uniform loadings can be analyzed. It is necessary to look at a “trial wedge” method or “approximation” method when attempting to analyze broken back slopes or other slope/load combinations.

AASHTO and NCMA suggest an approximation method for broken-back slope conditions that defines equivalent design slopes for the external analysis. However, the internal analysis is not well-defined for unusual slopes and loading conditions and the designer is expected to use engineering judgment with the simplified methods.

When checked on the design tab, the KeyWallPRO program uses a “trial wedge” analysis for determining external forces in order to provide a more accurate result for more complicated design geometries. The “trial wedge” calculation is an iterative process that determines the loading at successive failure plane orientations until a maximum loading is determined for the geometry and surcharge loading (See Figure 3:4).

#### Note:

*The AASHTO LRFD method uses the AASHTO “Simplified” method for calculating internal pressures and the trial wedge for calculating external loading conditions.*

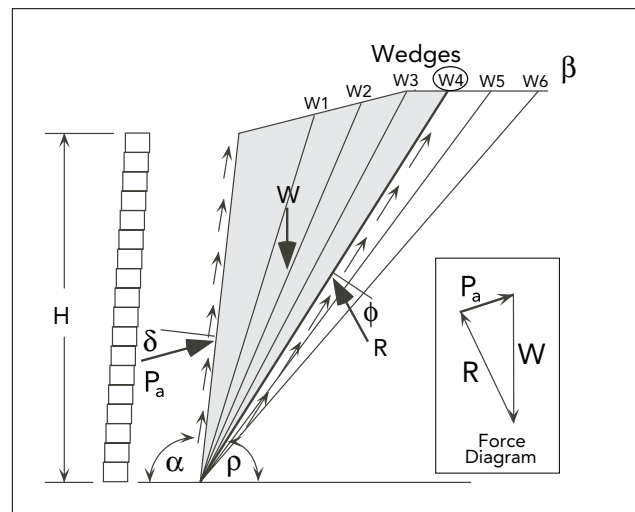

Figure 3:4 Trial Wedge Diagram

The KeyWallPRO “trial wedge” analysis used is consistent with the fundamental assumptions of the applicable Coulomb and Rankine theories by setting  $\delta = \beta$ . “Trial wedge” results match the equation solutions for the level and infinite slope conditions, but will more accurately determine the internal and external values for broken back slope conditions and offset live and dead loads. This method of analysis permits the designer to properly model many typical design conditions and not overly simplify the analysis due to limitations of equation solutions and other design software.



## BEARING CAPACITY

Bearing capacity is the ability of the foundation soil to support additional loading imposed on the surface from the completed wall system. Bearing capacity is analyzed considering two criteria:

- Shear capacity of the soil
- Total and differential settlement

Shear capacity of the soil is a function of the foundation soil strength, the soil mass equivalent footing size, the depth of embedment, and any groundwater conditions as determined by the geotechnical investigation.

## APPLIED BEARING PRESSURE

Figure 3:5 shows the Meyerhof distribution of applied bearing pressure for flexible foundation systems that is typically utilized with earth reinforcement structures.

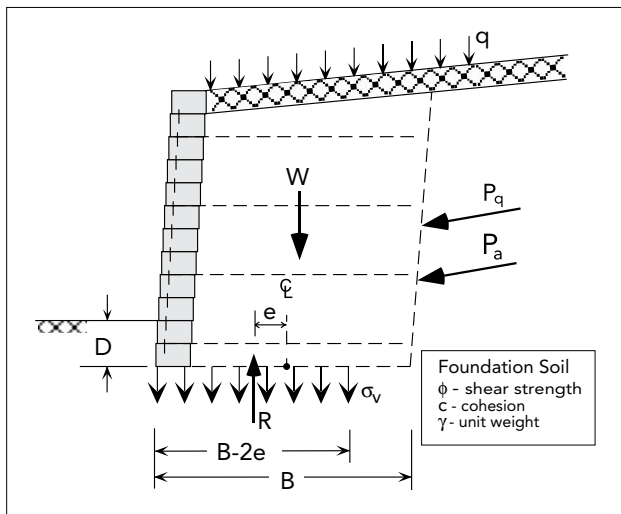

Figure 3:5 Applied Bearing Pressure Diagram

The equivalent footing width and applied bearing pressure are calculated as follows:

**Equation (3i)**  $e = B/2 - (M_r - M_o)/R_v$

**Equation (3j)**  $\sigma_v = R_v/(B - 2e)$

where:

- e = eccentricity of reaction
- B = total length of base
- $M_r$  = sum of resisting moments
- $M_o$  = sum of overturning moments
- $R_v$  = sum of vertical reactions



### PART THREE

## Retaining Wall Design Theory

### CALCULATED BEARING CAPACITY

$Q_{ult}$  is the ultimate bearing capacity of the foundation soils based on the soil and geometry parameters. The ultimate foundation bearing capacity can be calculated from the following Meyerhof equation:

$$Q_{ult} = cN_c s_c d_c + \gamma DN_q s_q d_q + 0.5\gamma B N_\gamma s_\gamma d_\gamma$$

For which infinitely long strip footing with shape and depth factors = 1.0, and effective base width of  $B - 2e$ , simplifies to:

$$\text{Equation (3k)} \quad Q_{ult} = cN_c + \gamma DN_q + 0.5\gamma(B - 2e)N_\gamma$$

where:

- $c$  = cohesion of foundation soil
- $\gamma$  = unit weight of foundation soil
- $D$  = depth of embedment below grade
- $B - 2e$  = effective footing width
- $N_c$  = bearing capacity factor for cohesion
- $N_q$  = bearing capacity factor for embedment
- $N_\gamma$  = bearing capacity for footing width

### BEARING CAPACITY FACTORS

Bearing capacity factors for the bearing capacity equation (through Vesic 1975) are as follows:

$$N_c = (N_q - 1) \cot \phi$$

$$N_q = e^{\pi \tan \phi} \tan^2(45 + \phi/2)$$

$$N_\gamma = 2(N_q + 1) \tan \phi$$

The factor of safety for bearing capacity is the ratio of ultimate bearing capacity to the calculated applied bearing pressure.

$$\text{Equation (3l)} \quad FS_{\text{bearing}} = Q_{ult} / \sigma_v$$

A minimum safety factor of 2.0 (NCMA and Rankine) against bearing capacity failure is considered acceptable for flexible earth reinforced structures.

AASHTO LRFD computes a capacity demand ratio (CDR) for bearing capacity using the equation below:

$$\text{Equation (3m)} \quad CDR_{\text{bearing}} = Q_{ult} RF_b / \sigma_v \text{ (factored loads)}$$

The MSE wall bearing resistance factor is  $RF_b = 0.65$ . As is always the case, the bearing capacity demand ratio is  $> 1.0$ .

**Note:**  
*In some cases, bearing capacity is determined without considering the wall embedment portion of the equation,  $\gamma DN_q$ . See KeyWallPRO Settings > Options dropdown menu item for this option. KeyWallPRO does not consider the sloping toe condition when determining bearing capacity.*



## BEARING CAPACITY FACTORS (continued)

Bearing capacity in KeyWallPRO is based solely on the soil parameters input for the foundation soil and the embedment depth assuming that the ground is level in front of the wall. The designer may check for a total stress condition by inserting total stress parameters for the foundation soil.

$\phi$	$N_c$	$N_q$	$N_\gamma$
0	5.14	1.00	0.00
5	6.49	1.57	0.45
10	8.34	2.47	1.22
15	10.98	3.94	2.65
20	14.83	6.40	5.39
25	20.72	10.66	10.88
30	30.14	18.40	22.40
35	46.12	33.30	48.03
40	75.31	64.20	109.41

Bearing Capacity Factors (Vesic 1975)

## SETTLEMENT

Settlement criteria may limit design bearing pressures for structures having large footing areas, such as mat-type foundations and bearing areas under MSE wall systems. By reviewing equation (3k), it is easy to see that with a large “B”, the shear capacity of the foundation is usually sufficient. However, with larger footing widths, the area of influence below the loaded area becomes quite large, typically 2B, and the addition of this vertical stress over a large area can induce significant settlement. It is important that the designer distinguishes between allowable bearing capacity for shear failure (a catastrophic failure mechanism) and a settlement criterion (a non-catastrophic event).

Total settlement is limited by the designer’s performance criteria and impact on adjacent structures or tolerances on vertical movements. As long as the structure settles uniformly, there is no significant structural effect on the wall system. Differential settlement, however, will cause a flexural movement in the wall face and may lead to unit realignment and cracks to relieve tensile stresses in the concrete. Differential settlements typically should be limited to 1% (i.e., 1 foot in 100 feet) (NCMA) or ½% (i.e., 1 foot in 200 feet) (AASHTO).

Settlement analysis is beyond the scope of this document, and is not included in the KeyWallPRO analysis. Due to the variability of foundation conditions, potential influences of groundwater, and other subsurface conditions, it is recommended that a qualified geotechnical engineer be consulted for proper analysis and specifications.

**Note:**

*Limit State or LRFD analysis requires a service state analysis in addition to the strength analysis. KeyWallPRO provides this bearing pressure in addition to the factored bearing pressure for comparison.*

**Note:**

*The designer is cautioned about spanning box culverts, constructing walls over uncompacted utility trenches, going directly from a rock foundation to a soil foundation, or transitioning from any elastic bearing surface to a rigid foundation surface. Differential settlements in such a short distance will be detrimental to any structure, and vertical construction slip joints are recommended.*



## PART THREE

### Retaining Wall Design Theory

## GLOBAL STABILITY

Global stability analysis is beyond the scope of this document and is not included in the KeyWallPRO program. However, it can be a necessary part of a comprehensive design analysis on larger projects and is best performed by the site geotechnical engineer.

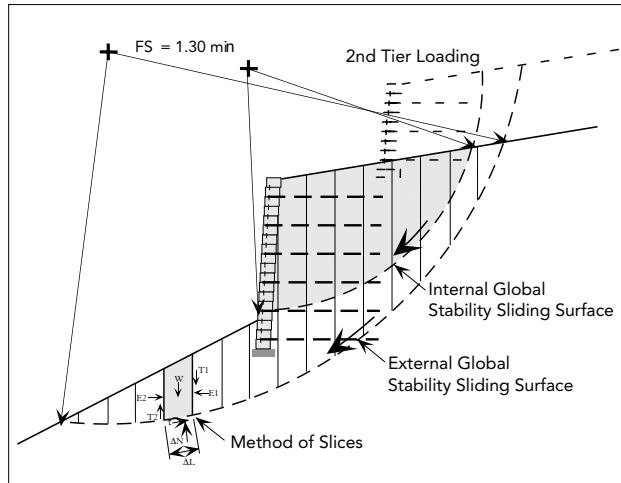

Figure 3:6 Global Stability Section

Global stability should be investigated any time the following situations occur:

- Steep slopes away from the toe of wall
- Steep slopes above the top of wall
- Tiered wall construction
- Poor foundation soils

Slope stability is a complicated analysis that depends on site geometry, construction methods, tested soil parameters and potential influence of groundwater. It is recommended that a qualified geotechnical engineer be consulted for proper analysis and recommendations.

A minimum Factor of Safety of 1.3 is required by NCMA and AASHTO. A higher factor ( $FS = 1.5$ ) may be required for critical structures such as bridge abutments. AASHTO LRFD requires similar ratios.

AASHTO requires resistance factors of 0.75 ( $FS = 1.33$ ) and 0.65 ( $FS = 1.54$ ) for retaining walls and abutments, respectively. However, LRFD calibration has not been performed on stability procedures and no software exists to perform such analysis. Thus, conventional factors of safety of 1.3 and 1.5 are utilized per previous ASD codes.

## INTERNAL COMPOUND STABILITY ANALYSIS

NCMA's Design Manual, 3rd Edition, introduced the concept of internal compound stability (ICS) which is a limited form of global stability analysis that checks failure planes through the wall facing. The analysis includes loading conditions within a limited distance outside of the reinforced zone and is therefore considered a compound analysis.



## INTERNAL COMPOUND STABILITY ANALYSIS (continued)

ICS is not a substitute for global stability analysis. This limited analysis only considers failure circles with entry points that originate a distance of  $2H$  or  $H_{ext} + L$  behind the front face of the wall and exit points that pass through either:

1. Tangent to the base of the block at the leveling pad.
2. At the block/block interface.
3. At a block/reinforcement/block interface.

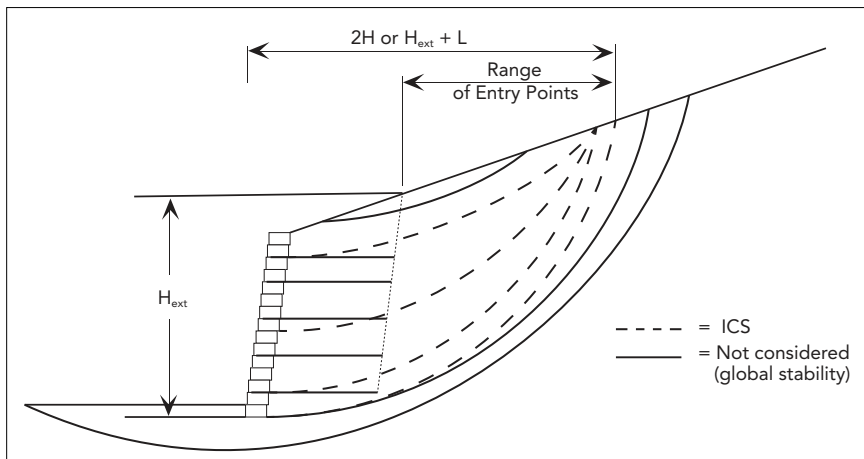

Figure 3:7 Range of Failure Circles

See figure 3.7 which shows some possible circular failure surfaces and range of entry and exit points that are checked. Failure surfaces that are outside of the scope of ICS are also included for clarity.

To determine the ICS safety factors, the soil mass above the circular failure surface is divided into slices and each slice analyzed using the Simplified Bishop procedure. The Simplified Bishop procedure makes the following assumptions:

1. Circular slip surface.
2. Shear stresses (horizontal forces) between slices are ignored.
3. Moment equilibrium about the center of the circle is satisfied.
4. Force equilibrium in the vertical direction is satisfied.

Below is the general form of the ICS factor of safety for the reinforced wall with known inclusions from the soil reinforcement and facing.

$$FS_{\text{reinforced}} = FS_{\text{unreinforced}} \frac{MR_{\text{reinforcement}} + MR_{\text{facing}}}{MR_{\text{driving}}}$$

(Please consult the NCMA 3rd Edition Design Manual for a full explanation of the ICS analysis.)

The minimum Factor of Safety for ICS is 1.3. The factor of safety can be improved by using longer reinforcements, closer reinforcement spacing, stronger reinforcements or improved reinforced backfill. The NCMA 3rd Edition allows a factor of safety below 1.3 in the uppermost failure circles if stability of the slope has been evaluated or improved by other means.

**Note:**

*NCMA compound stability analysis is an empirically limited internal stability check and does not replace global stability analysis external stability check.*



### PART THREE

## Retaining Wall Design Theory

### SEISMIC ANALYSIS

Keystone retaining wall structures have proven to be earthquake resistant due to the system's inherent flexibility that permits minor yielding during a major seismic event.

The most recent seismic design standards are contained in the AASHTO Standard Specifications for Highway Bridges (Chapter 11) and in the 3rd edition of the NCMA Design Manual, which describe a pseudo-static method of analysis based on the Mononobe-Okabe application of conventional earth pressure theory.

A schematic of pseudo-static analysis considerations is shown in Figure 3:8 below as it pertains to reinforced soil structures.

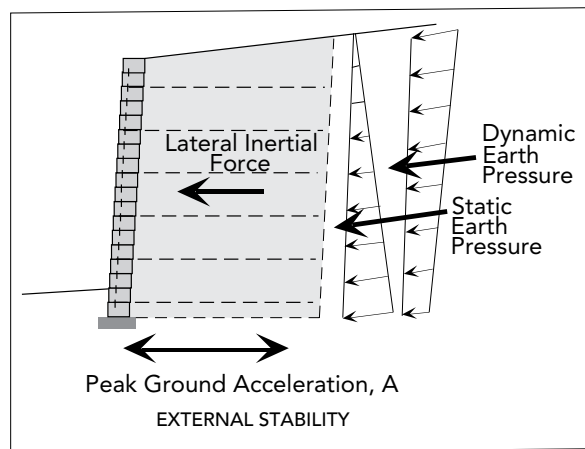

Figure 3:8 External Stability

The details of seismic analysis are beyond the scope of this manual and other documents should be consulted. There are many ways to evaluate seismic forces, which are quite complicated. The KeyWallPRO program uses three different methods that parallel the three different design methodologies of NCMA, Rankine, and AASHTO.

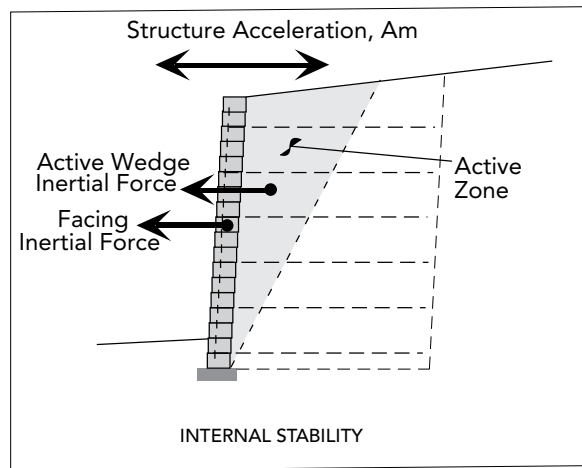

Figure 3:9 Internal Stability



# PART FOUR

## THE DESIGN PROCESS

*Drury Hotel, Cape Girardeau, Missouri; Broadstone® - RockFace*

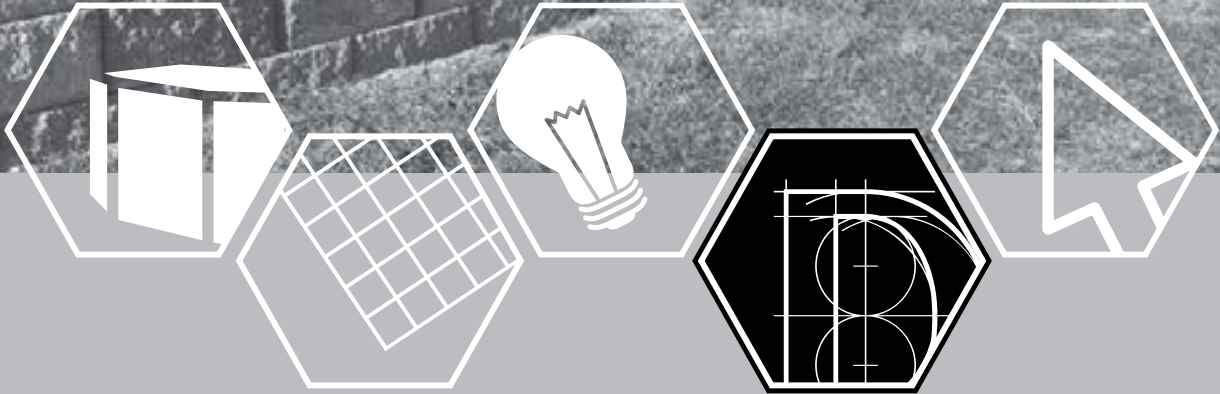
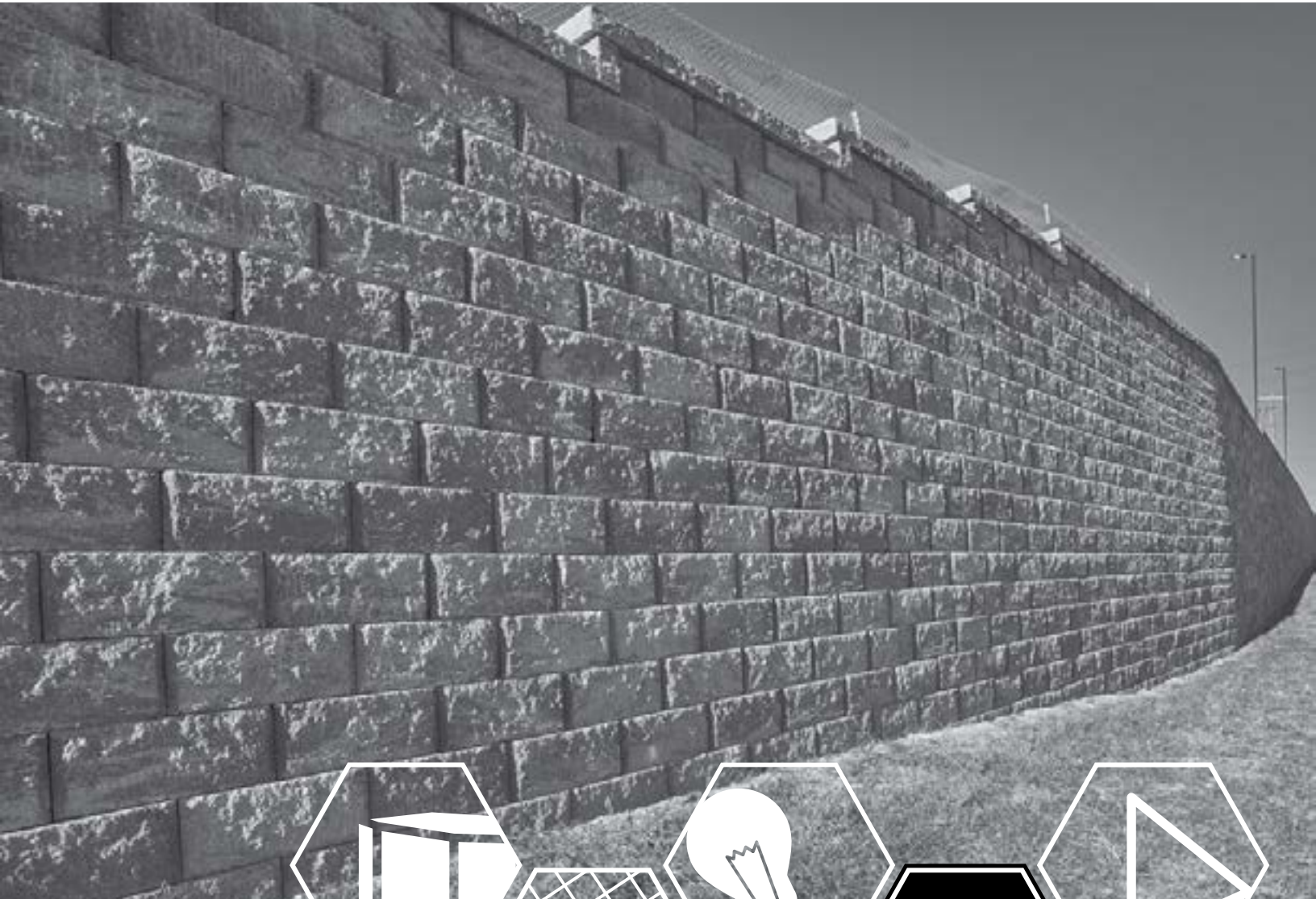



## INTRODUCTION

After discussion of the Keystone units' properties, geogrid soil reinforcement, and earth pressure theory, it's time to put the pieces together into a Keystone Wall System design. The parameters required for the design of a Keystone earth retaining structure are: choice of design methodology, Keystone unit, wall batter, wall geometry, soil types and properties, surcharge loading conditions, and reinforcement type and properties. The external stability items checked during the design include: sliding of the gravity wall, sliding at the base of the reinforced zone or along the lower layers of geogrid reinforcement, overturning about the toe, and applied bearing pressure.

The internal stability items checked during the design include: tensile strength of reinforcing, Keystone unit reinforcement connection, pullout capacity of the reinforcing beyond the theoretical failure plane, and local stability of the facing - shear and bending.

*Note: For walls with slopes below the toe, potentially weak foundations, tiered walls, or tall slopes above the walls, global slope stability should be analyzed as part of a geotechnical investigation. Gross and differential settlement should also be checked as required by the structure design.*

The following sections describe the steps taken in the design analysis; however, the trial and error process for actual reinforcement selection and placement is not discussed in detail. It is assumed the reader has used the KeyWallPRO program for the proposed design and is ready to confirm the results obtained. The details of a complete design analysis are tedious and are best performed by computer and verified by hand.

*Aloft Hotel, Atlanta, Georgia; Regal Stone Pro® - RockFace*





## PART FOUR

### The Design Process

## DESIGN METHODOLOGY

**Note:**

*A common misuse of Coulomb theory is to calculate the lower earth pressure and then fix the failure plane at the steeper Rankine slope ( $45^\circ + \phi/2$ ) for the purposes of the pullout resistance calculation. This is not in accordance with any established design methodology.*

**Note:**

*A common concern is that the facing and soil mass can move down together in a flexible wall system without a rigid foundation, which would eliminate the stabilizing effects of assumed wall friction on the failure wedge and the resulting lower Coulomb earth pressure.*

It is first necessary to select and understand the design methodology that will be used for a specific project. The NCMA Coulomb methodology is based on fundamentally different principals than the Rankine and AASHTO methodologies and will provide different results in both the internal and external calculations due to these differences. The most important issue is that the designer understand and be comfortable with a design methodology and its limitations, then follow the methodology in its entirety.

The advantage of using a Coulomb earth pressure methodology is that it can provide the lowest calculated earth pressure in a given situation by taking all beneficial components into account (wall batter and wall friction). However, it also requires that the reinforcement lengths be significantly longer at the top of wall than bottom of wall due to the flatter slope of the calculated Coulomb failure plane. Also, the reduced earth pressure may permit vertical spacing of the reinforcement in lower walls that exceed the wall facing's ability to remain stable during construction and in the final configuration (facial stability at top of wall and between reinforcement levels).

The advantage of using a Rankine earth pressure methodology is that no assumption has to be made with regard to friction between the wall structure and retained soil mass. Also, the Rankine theory provides simpler formula and failure plane definitions which are easier to use and check. Rankine earth pressure theory has been the established methodology for earth reinforcement design in the public sector since the early 1970s, which provides a certain level of comfort to many designers. KeyWallPRO provides the designer choices for NCMA 3rd Edition, Rankine, AASHTO 2010 (LRFD), AASHTO 2015 (LRFD), and AS 4678 (Australia) as the design methods.

## UNIT SELECTION

To begin the design process, a selection of the preferred Keystone Unit is required. As a general guideline, for small gravity walls 3 - 6 feet high (1-2m), the Keystone Standard unit is the preferred choice. Below 3 feet (1m) high, the Keystone Compac, Regal Stone Pro, Broadstone, or Valera units may be selected. For taller walls or walls supporting surcharge loadings, where soil reinforcement generally will be required, any of the structural units can be constructed to a desired height using the appropriate soil reinforcement design. The Keystone Standard unit is considerably more stable during construction and is preferred for the larger, more critical wall structures. The Keystone Compac, Regal Stone Pro, Broadstone, or Valera units require that the soil reinforcement be placed in smaller vertical lifts due to the decreased facial stability of the smaller units and reduced connection strength. These design options can be quickly checked with KeyWallPRO software to determine the most effective design.



## WALL BATTER

Batter of the wall is the designer's or contractor's choice depending on the appearance desired, right-of-way available, and degree of wall curvature expected. Battered walls are usually required for gravity walls. Battered walls work poorly in tight curves and in sharp corners as the wall units move away or towards each other resulting in cut pieces or increasing gaps. Since the Keystone Standard and Keystone Compac units can be constructed with either a "near-vertical" or 1-inch (25mm) minimum setback batter per course, it is recommended that only reasonably straight walls be constructed with the 1-inch setback, and walls with tight curves and corners be constructed with the near vertical alignment to facilitate construction. The lip/lug units have a single batter option built in. See chart below:

It is very important that if a batter is assumed in the design, that the wall be specified and constructed with the designed batter, due to the fact that wall batter reduces the calculated earth pressure.

Unit	Batter
Keystone Standard I, III	0.8°
Keystone Compac II, III	0.8°
Regal Stone Pro	7.1°
Broadstone	1.8°
Valera	4°

**Note:**

*With greater batter, more lateral space is required for the wall system, i.e., for a 8° batter, 2.8 feet (0.85m) of right-of-way will be lost for a 20-foot (6.1m) wall height.*

## WALL GEOMETRY

The design wall height is always measured from the top of the leveling pad to the top of wall. The design height of the wall is determined from the site geometry, including the appropriate embedment. Designs must be prepared for the different wall sections as defined by the site conditions. The backslope geometry is modeled by defining a slope angle ( $\beta$ ) in degrees from horizontal and measuring the length of the slope (horizontal offset) above the top of the wall.

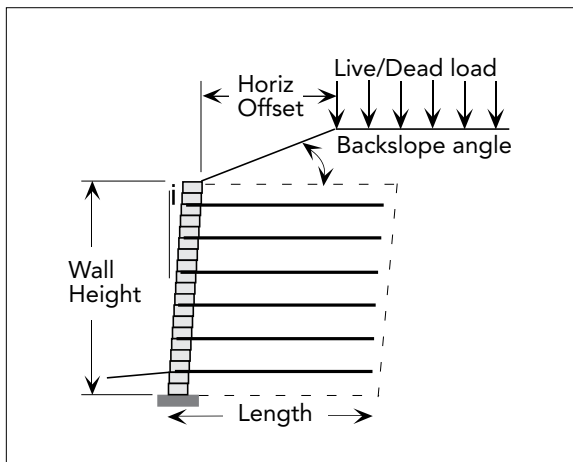

Figure 4:1 Design Section

**Note:**

*KeyWallPRO models the slope from the back of the Keystone unit to crest of backslope. Beyond that, the backfill is assumed horizontal and may have a live or dead load surcharge applied on this surface.*



## PART FOUR

### The Design Process

#### Note:

*Project plans, specifications, and design codes may require minimum embedments that exceed the minimums recommended by NCMA.*

## WALL EMBEDMENT

For small Keystone gravity walls, a minimum 1 inch (25mm) of embedment is recommended for every unit of height (i.e., H/8) or 1 block minimum, whichever is greater. For reinforced soil for Keystone walls, the minimum depth of embedment as a ratio to wall height may be determined in the following table:

Slope in Front of Wall	NCMA	AASHTO	Keystone Construction Manual
	Min. Embedment	Min. Embedment	Min. Embedment
Minimum Requirement	0.5 ft (150mm)	2ft. Minimum	0.5 ft
Horizontal (walls)	H/20	H/20	H/20
Horizontal (Abutments)	H/10	H/10	H/10
3H:1V	H/10	H/10	H/10 + 1.33 ft
2H:1V	H/7	H/7	H/10 + 2 ft

## SLOPING TOE

The minimum embedment required with a slope in front of the wall should be based on the establishment of a minimum 4-foot (1.2m) horizontal bench in front of the wall and establishing a minimum embedment from that point. Fill slopes usually have poor compaction near the edge of the slope, and all slopes are subject to erosion and superficial instability.

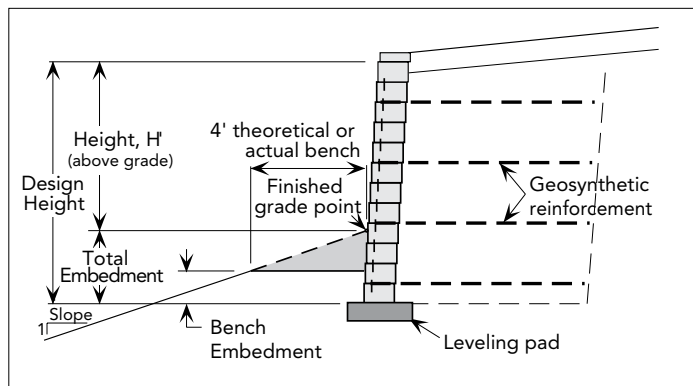

Figure 4:2 Sloping Toe

The depth of embedment should be increased when any of the following conditions occur:

- Weak bearing soils
- Potential scour of wall toe
- Submerged wall applications
- Significant shrink/swell/frost properties of foundation soils



## SOIL PROPERTIES

The purpose of a retaining wall system is to safely hold a wedge of soil in place to make a grade change in the shortest possible distance. The angle of internal friction ( $\phi$ ), cohesion ( $c$ ), and unit weight ( $\gamma$ ) of the soils determine the force that will be exerted by the soil wedge on the wall structure. The figures 4:3 & 4:4 describe a simple shear test and test data plot that show the soil strength properties. Some typical design  $\phi$  and  $\gamma$  ranges for compacted or dense soils are shown in the Shear Strength and Weight Range Table.

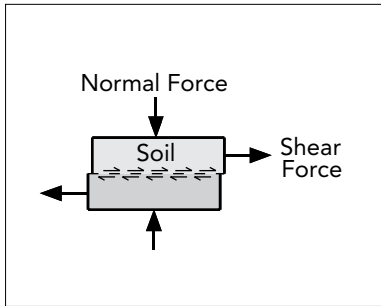

Figure 4:3 Soil Shear Test

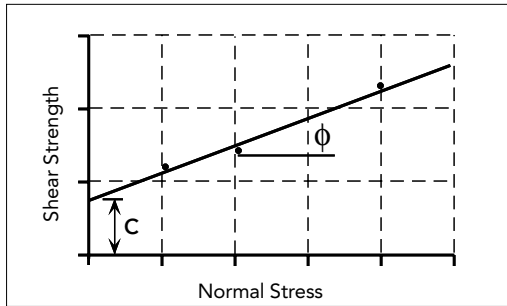

Figure 4:4 Soil Shear Plot

Soil Type	$\phi$ - Angle	$\gamma$ - Weight
Crushed Stone, Gravel	34°+	110-135 PCF (17-21 kN/m <sup>3</sup> )
Sands	30°-34°	100-130 PCF (16-20 kN/m <sup>3</sup> )
Silty Sands/Sandy Silt	28°-30°	100-125 PCF (16-20 kN/m <sup>3</sup> )
Sandy Clay, Lean Clay	26°-28°	100-120 PCF (16-19 kN/m <sup>3</sup> )
Other Clays	Determined by Testing	

Shear Strength and Weight Range

A qualified geotechnical engineer should be consulted to establish the soil properties for a site. Reasonable design values can usually be estimated by a qualified engineer based upon visual observation and history of the soils encountered. Additional soil borings and laboratory testing may be required for taller walls or difficult site soil conditions.

**Note:**

*The required embedment depth for Keystone walls may become a controversial issue. The Internal Building Code (IBC) recommends a 1' minimum or below prevailing frost depth, whichever is greater for foundations. AASHTO recommends a 2' minimum or below prevailing frost depth, whichever is greater for retaining structures. These minimum recommended depths are based on rigid foundation systems and are not totally applicable to flexible systems, which function properly with significantly less embedment. The proper embedment depth is a function of the structure size and type, the underlying soils, and the site geometry, especially toe slopes. It is significantly more important to properly inspect the foundation area when excavated, determine the limits of removal and replacement of unsuitable materials, and then confirm the final embedment depth for stability and bearing given the site conditions.*



## PART FOUR

### The Design Process

## NO-FINES CONCRETE BACKFILL

No-fines concrete backfill can be used to increase the mass of Keystone retaining walls by combining the Keystone wall facing to increase the resistance to sliding and overturning. This allows the maximum gravity wall height to be exceeded while limiting the excavation required. It is ideal for boundary walls where soil reinforcement would otherwise cross onto the neighboring property.

No-fines concrete consists of cement, water and coarse  $\frac{3}{4}$ " aggregate. The material is free-draining with a 20% to 30% void ratio. The density ranges from 110 pcf to 130 pcf. The material has zero slump and is placed with a wheelbarrow or bucket similar to drainage aggregate.

Placement of no-fines concrete inside and around the voids of Keystone units is required and provides the anchorage of the Keystone units to the no-fines concrete. It is important to work the no-fines concrete between and within the units similar to the placement of drainage fill. This allows the units to be anchored to the no-fines concrete, forming one mass. During installation, the wall may need to be braced and pours limited to 3 courses tall.

A minimum base width of 40-50% is typically used for no-fines concrete backfill, although a base width greater than 50% may be required for poor soil conditions. The final determination of the base width depends on the retained soil properties.

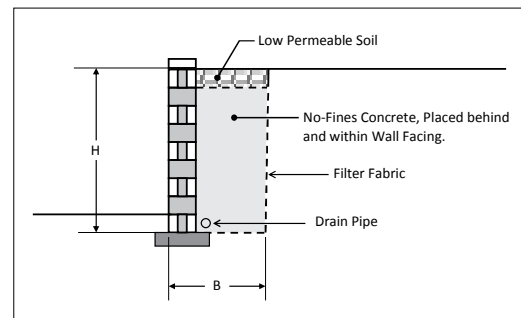

Figure 4:5 No-fines Concrete Section

## SURCHARGE

A surcharge is a loading imposed on the soil behind the wall that exerts an additional force on the potential failure zone. For simplification in the KeyWallPRO program, all surcharge loadings are assumed to be uniform live or dead loads. Line and point surcharge loads are not within the scope of this manual. Typical live load surcharge loadings are:

- Landscaping walls -- 0 psf
- Pedestrian traffic, light storage -- 50 psf (2.4 kPa)
- Light-traffic, auto parking -- 100 psf (4.8 kPa)
- Highway loading, heavy traffic -- 250 psf (12 kPa)

To model surcharge loading above a sloping backfill condition, KeyWallPRO users must specify the correct horizontal offset (see Figure 4:1). If the surface is level, but the surcharge is a short distance back from the wall face, the designer may input a horizontal offset to move the load away from the back of wall units.

Surcharge live loads are used in the external stability analysis as driving forces, but are not included as resisting forces.

For heavy loadings due to equipment, railroads, footings, closely spaced tiers, etc., a Boussinesq stress distribution may be more applicable. The designer should analyze the wall with the appropriate uniform surcharging from imposed dead loads, then superimpose the earth pressure diagram for line or strip loads by hand or with the aid of a spreadsheet analysis.



## REINFORCEMENT TYPE & PROPERTIES

Geosynthetic reinforcement for retaining walls are generally geogrids specifically designed and tested for use as soil reinforcement. The basic design criteria is covered in part three of this manual.

The selection of polymer type or manufacturer of the reinforcement is a subjective determination based upon the specific design considerations of a project. Each type of reinforcement can be used safely provided that the appropriate durability, installation damage, and long term creep factors are determined for a given application based on field and laboratory test data.

Each manufacturer should be able to provide test documentation for the recommended values contained in their product's technical literature. It is the designer's responsibility to evaluate the manufacturer's product test data and determine the grid types and design values appropriate for the project.

The strength level of reinforcement to be used in a wall design is a function of wall height and loading. Lower walls will generally use lower strength reinforcement, while taller walls will require stronger reinforcement. The designer may utilize lower strength reinforcement spaced closer together instead of higher strength reinforcement or different strengths within the same wall section to meet the design requirements. Construction and cost considerations typically govern this selection process.

## SOIL REINFORCEMENT LENGTH

Irrespective of the design computations, minimum base to height proportions for MSE walls have been developed based on history and successful field performance.

In accordance with the NCMA Design Manual, the minimum reinforcement length shall be  $0.6H$  for all wall applications. Per AASHTO, the minimum length shall be  $0.7H$  or 8 foot minimum (2.44m), whichever is greater (AASHTO LRFD has provisions for 6' min. length (1.8m) under certain conditions). The minimum length shall be as stated or as required for external stability, whichever is greater. All lengths represent the depth of the reinforced mass to resist external forces; therefore, all lengths are measured from the front face of the wall system to the back of the reinforcement.

NCMA further recommends that the soil reinforcement extend beyond the Coulomb failure plane a minimum of 1 foot (300mm). AASHTO recommends that the reinforcement extend 3 feet (1m) past the Rankine failure plane.

The choice of 60% or 70% of height for minimum reinforcement length is one of design specification and the designer's preference. There is considerable evidence that walls experience greater deformation with shorter reinforcement "L/H" ratios ( $L/H < 0.5H$ ).

AASHTO requires that reinforcement be uniform in length, while NCMA permits varying reinforcement lengths as required by the internal and external stability calculations. Keystone recommends providing uniform reinforcement lengths within a wall section as a general rule, to avoid excessive detailing on the plans and confusion by the contractor during installation.

### Note:

*The external stability analysis of a reinforced soil structure is similar for the Coulomb/NCMA and Rankine/AASHTO methodologies except that the Coulomb/NCMA method neglects the vertical component of the external forces whereas the Rankine/AASHTO methods include the stabilizing effects of the vertical component for sloping backfills,  $\beta > 0$ .*

*The Rankine and AASHTO methods use essentially the same external analysis method. The only differences relate to AASHTO design code recommendations such as minimum L/H ratio and minimum reinforcement length requirements.*





## EXTERNAL STABILITY ANALYSIS

External stability is the wall structure's ability to resist external sliding and overturning forces and the foundation's ability to support the structure. The wall system must be proportioned to provide adequate safety against applied soil and surcharge loads.

A typical external force analysis for a simple gravity wall is shown in Figure 4:6. Gravity walls rely solely on the mass of the facing units to resist external forces.

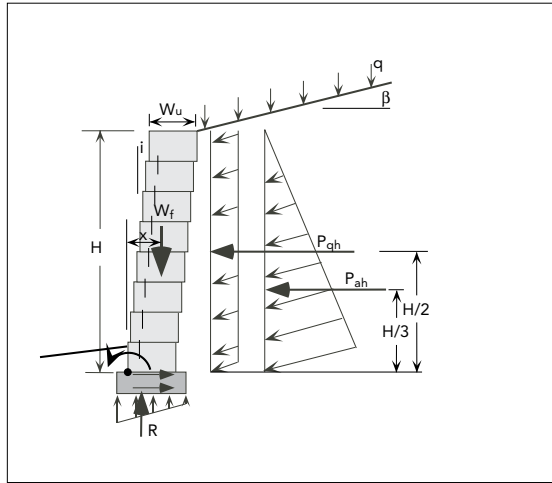

Figure 4:6 Gravity Wall Force Diagram

A typical external force analysis for a simple reinforced soil wall is shown in Figure 4:7. The reinforced soil section is treated as a coherent gravity mass and analyzed externally as a rigid body similar to the gravity wall.

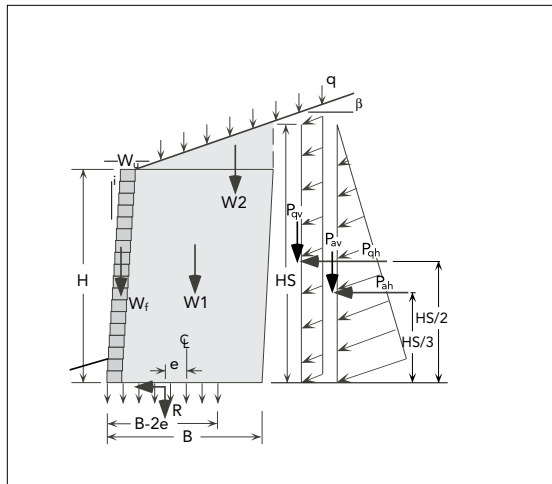

Figure 4:7 Reinforced Wall Force Diagram



## BATTERED WALL DESIGN OPTIONS

Battered walls can create some problems in the design analysis since the geometry becomes more complex than vertical walls and the application of weights and loads is not as clear.

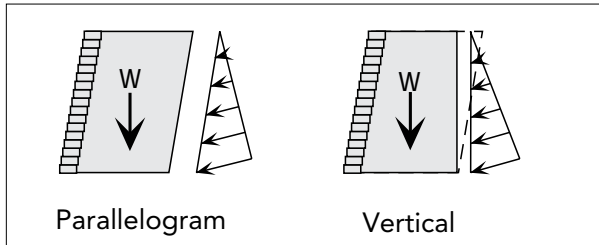

Figure 4:8 Design Options

### Parallelogram

The parallelogram method calculates the weight of the battered reinforced mass over the base as indicated including the wedge of soil that is not over the base. Active earth pressure is determined based on the batter of the reinforced zone interface with the retained soil. This is the basis for the NCMA and Rankine stability analysis.

### Vertical

The vertical method calculates only the weight of the battered reinforced mass that is over the base as indicated. Active earth pressure is determined based on a vertical interface between the reinforced zone and the retained soil. This is the basis of the AASHTO LRFD design method in KeyWallPRO.

## AASHTO LRFD

Load Resistance Factor Design (LRFD) is the next step in the evolution of US engineering design practice. MSE retaining walls have traditionally been designed (and still are) using allowable stress design (ASD) and factor of safety (FS) methods. Concrete structures have been designed using LRFD methods for many years followed by steel structure design adopting similar methods. The difference between LRFD and ASD/FS is in how the uncertainties of the design are handled. Allowable stress design uses a single variable, factor of safety, to handle uncertainties. The general form of ASD is shown below:

**Equation (4b)**      $R/P \geq FS$

where:

- R = resistance (stabilizing forces)
- P = load (destabilizing forces)
- FS = factor of safety



## PART FOUR

### The Design Process

#### AASHTO LRFD (continued)

Load resistance factor design uses multiple variables to handle uncertainties. Load factors are applied to each of the different types of loads: live, dead, horizontal and vertical. Resistance factors are applied to the nominal resistance. The load factor and resistance factors are set based on statistical data and can better represent the uncertainties compared to ASD/FS design methods. The general form of LRFD is shown below.

$$\text{Equation (4c)} \quad \text{CDR} = \phi R / (\gamma_{t1} P_{t2} + \gamma_{t2} P_{t2}) > 1.0$$

where:

- $\phi$  = resistance factor
- R = resistance (stabilizing forces)
- $\gamma_{t1}, \gamma_{t2}$  = load factor for a certain load type
- $P_{t1}, P_{t2}$  = load of a certain type (destabilizing forces)
- CDR = capacity demand ratio

Given the nature of retaining wall design where certain loads contribute to the calculation of the resistance, R, load factors are also used to compute the nominal resistance. For example, in the sliding calculation, the weight of the reinforced zone contributes to the resisting force. A resisting load factor is applied to this load. AASHTO lists both driving load factors (maximum) and resisting load factors (minimum) in Chapter 3 of the 2010 Standard Specifications for Highway Bridges. The applicable load factors are shown in the table below:

#### Strength I

Driving Load Factors	Resisting Load Factors
$EH_d = 1.50$	$EH_r = 0.90$
$EV_d = 1.35$	$EV_r = 1.00$
$ES_d = 1.50$	$ES_r = 0.75$
$LL_d = 1.75$	

AASHTO LRFD Load Factors

#### Extreme I (Seismic)

Driving Load Factors	Resisting Load Factors
$EH_d = 1.50$	$EH_r = 0.90$
$EV_d = 1.35$	$EV_r = 1.00$
$ES_d = 1.50$	$ES_r = 0.75$
$LL_d = 0.50$	$LL_r = 0.00$
$EQ = 1.00$	n/a

Resistance factors for the external and internal failure mechanisms are listed below:

Strength I	Extreme I
Sliding $RF_{sl} = 1.00$	Sliding $RF_{sl} = 1.00$
Overturning = NA	Overturning = NA
Bearing $RF_b = 0.65$	Bearing $RF_b = 0.65$
Tension $RF_t = 0.90$	Tension $RF_t = 1.20$
Pullout $RF_{po} = 0.90$	Pullout $RF_{po} = 1.20$

AASHTO LRFD Resistance Factors



## SLIDING ANALYSIS

The sliding resistance of a Keystone gravity wall is calculated by determining the sliding resistance between 1) the wall unit and the leveling pad material interface, 2) through the leveling pad material, and 3) unit-to-unit shear above the leveling pad as indicated in Figure 4:9.

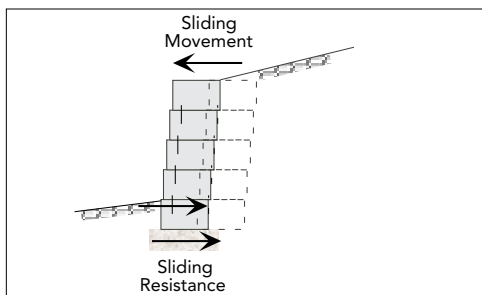

Figure 4:9 Gravity Wall Sliding

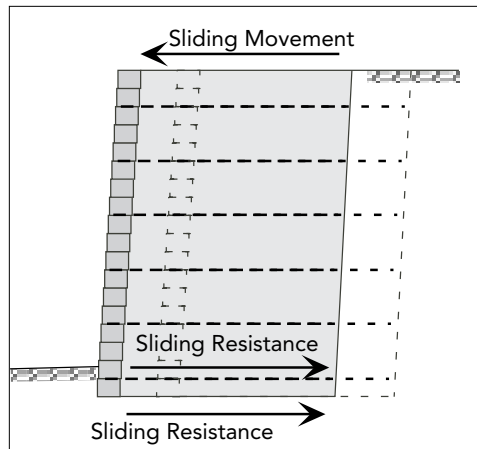

Figure 4:10 Reinforced Wall Sliding

The sliding resistance of a Keystone reinforced soil wall is calculated by determining the sliding resistance between 1) the reinforced soil zone and the foundation soil interface and 2) through the reinforced wall system along a reinforcement level as indicated in Figure 4:10.

For both gravity and reinforced walls, the driving force is calculated from Equations 3a and 3b for Coulomb active earth pressure and Equations 3e and 3f for Rankine active earth pressure.

The ratio of resisting forces to driving forces is calculated to determine a Factor of Safety against Sliding:

**Equation (4d)**  $FS_{sl} = \Sigma \text{Resisting Forces} / \Sigma \text{Driving Forces}$

Alternatively, AASHTO LRFD computes a sliding capacity demand ratio:

**Equation (4e)**  $CDR_{sl} = \Sigma \text{Resisting Forces (factored)} / \Sigma \text{Driving Forces (factored)}$

Resisting forces use minimum load factors. Driving forces use maximum load factors except for vertical earth load components.

**Note:**

*Gravity walls rarely fail in sliding as the overturning calculation generally controls the maximum design heights possible. On the other hand, reinforced soil structure design is typically proportioned based on sliding resistance and overturning rarely controls the design.*



## PART FOUR

### The Design Process

## COULOMB - NCMA-SLIDING

### Driving Forces

The horizontal earth pressure components,  $(P_a + P_q) \cos(\delta)$ , are the driving forces.

### Resisting Forces

Gravity wall analysis calculates inter-unit shear, unit-to-leveling pad shear, leveling pad shear resistance based on the weight of wall,  $W_f$ .

Reinforced soil wall analysis calculates soil-to-soil sliding resistance  $(W_f + W_1 + W_2) \tan \phi$  of the weaker soil (reinforced or foundation) as the resisting force. The 3rd edition of the NCMA Design Manual now permits the inclusion of vertical earth load components at the designer's option.

## RANKINE - AASHTO-SLIDING

### Driving Forces

The horizontal earth pressure components,  $(P_a + P_q) \cos(\beta)$ , are the driving forces in ASD/FS analysis.

The factored horizontal earth pressure components,  $(EH_d P_a + ES_d \text{ or } LL_d P_q) \cos(\beta)$ , are the driving forces in LRFD analysis. Driving forces use maximum load factors, except for earth loads.

### Resisting Forces

Gravity wall analysis must calculate inter-unit shear, unit-to-leveling pad shear, and leveling pad shear resistance.

Reinforced soil wall analysis calculates sliding resistance as  $(W_f + W_1 + W_2 + P_{av} + P_{qv}) \tan \phi$  of the weaker soil in ASD/FS analysis.

The factored sliding resistance is  $RF_{sl} (EV_f W_f + EV_f W_1 + EV_f W_2 + EH_d P_{av} + ES_r P_{qv} \text{ (dead)}) \tan \phi$  of the weaker soil in LRFD analysis. Resisting forces use minimum load factors.

The reinforced soil wall sliding analysis becomes more complicated with geosynthetic sheet reinforcement because sliding must be checked along the lowest levels of reinforcement, as well as at the base of the mass (see Figure 4:10).

#### Note:

*Live load does not contribute to resisting forces.*



**RANKINE - AASHTO-SLIDING** (continued)

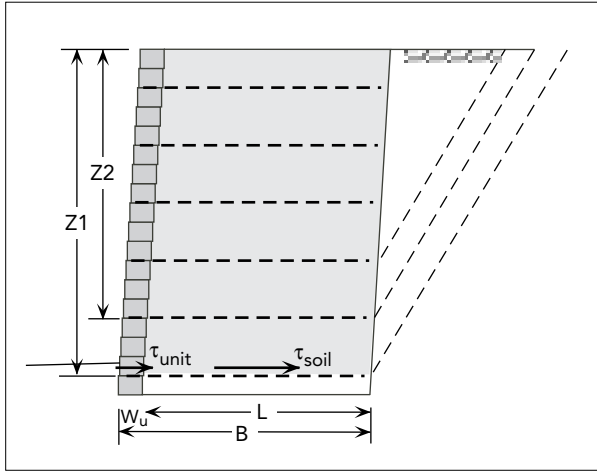

Figure 4:11 Internal Sliding Length

Driving forces are recalculated for each reinforcement level in the same manner as the external analysis.

The resisting force is calculated as the sum of the inter-unit shear and soil-to-geogrid interface shear:

$$\tau_{\text{unit}} = \text{from shear curve for unit with geogrid}$$

$$\tau_{\text{soil}} = \text{Weight} \times \tan \phi \times C_{ds}$$

For both gravity and soil-reinforced structures, a minimum factor of safety of 1.5 against sliding is required in ASD analysis. A minimum CDR of 1.0 is required in LRFD analysis.



## OVERTURNING ANALYSIS

Overturning is the wall's theoretical tendency to tip over due to lateral pressures exerted by the soil and any surcharge loading at the back of the wall system. In gravity wall design, overturning is a major design consideration since the units are rigid and have a small L/H ratio at relatively short heights.

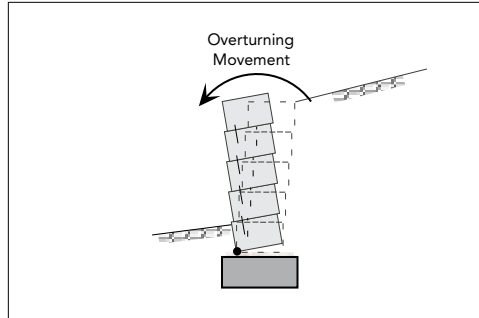

Figure 4:12 Gravity Wall Overturning

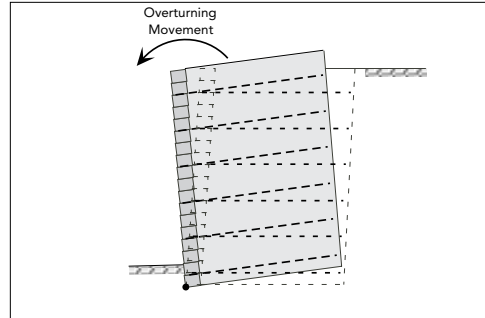

Figure 4:13 Reinforced Wall Overturning

In reinforced wall design, this “theoretical” overturning is not possible because the reinforcing is typically designed for a minimum L/H ratio of 60% or greater and the wall system is a flexible soil mass which cannot overturn.

The driving or overturning moment is the result of active earth pressure forces and surcharge forces pushing at the back of the wall system. Referring to Design Theory in Part Three, the active earth pressure force is a triangular pressure distribution with the maximum force at the base and the centroid is at  $1/3$  of the height. The surcharge load is a rectangular pressure distribution against the back of the wall system and the centroid of the rectangle is at  $1/2$  the height.

For both gravity and reinforced walls, the driving force is calculated from Equations 3a and 3b for Coulomb active earth pressure and Equations 3e and 3f for Rankine active earth pressure located in Part Three of this Manual.

The ratio of resisting moments to driving moments is calculated to determine a factor of safety against overturning.

$$\text{Equation (4f)} \quad FS_{OT} = \Sigma \text{ Resisting Forces} / \Sigma \text{ Driving Forces}$$

Alternatively, AASHTO LRFD computes an overturning capacity demand ratio:

$$\text{Equation (4g)} \quad CDR_{OT} = \Sigma \text{ Resisting Forces (factored)} / \Sigma \text{ Driving Forces (factored)}$$

Resisting forces use minimum load factors. Driving forces use maximum load factors except for vertical earth load components.



## COULOMB - NCMA OVERTURNING

### Driving Moments

The horizontal earth pressure components,  $(P_a + P_q) \cos(\delta)$ , are the driving forces at their respective moment arms of  $H/3$  or  $HS/3$  and  $H/2$  or  $HS/2$  up from the toe.

### Resisting Moments

Gravity wall analysis calculates the weight of the facing system,  $W_f$ , times the moment arm from toe to center of gravity of the facing column.

Reinforced soil walls calculate the weight of the entire system ( $W_f, W_1, W_2$ ) at their respective moment arm from the toe to each center of gravity as the resisting moment.

## RANKINE - AASHTO OVERTURNING

### Driving Moments

The horizontal earth pressure components,  $(P_a + P_q) \cos(\beta)$ , are the driving forces at their respective moment arms of  $H/3$  or  $HS/3$  and  $H/2$  or  $HS/2$  up from the toe in ASD analysis. AASHTO LRFD uses  $(E_{Hd} P_a + E_{Sd} \text{ or } LL_d P_q) \cos(\beta)$  for the driving force. Driving forces use maximum load factors, except earth loads.

### Resisting Moments

Gravity wall analysis calculates the weight of the facing system,  $W_f$ , times the moment arm from toe to center of gravity of the facing column in ASD analysis. AASHTO LRFD uses  $E_{Vr} W_f$  for the resisting forces.

Reinforced soil walls calculate the weight of the entire system ( $W_f, W_1, W_2$ )  $P_{av}, P_{qv}$  at their respective moment arm from the toe to each center of gravity as the resisting moment. AASHTO LRFD uses  $(E_{Vr} W_f, E_{Vr} W_1, E_{Vr} W_2, E_{Hd} P_{av}, E_{Sr} P_{qv})$ , for resisting forces. Resisting forces use minimum load factors.

## OVERTURNING

For soil reinforced structures, a 2.0 minimum factor of safety against overturning is required in ASD analysis. For gravity walls, a 1.5 factor of safety against overturning is typically required. LRFD analysis may or may not look at overturning ( $CDR > 1.0$ ) and rely on eccentricity criteria to limit overturning.

## BEARING CAPACITY

Bearing capacity is the capacity of the foundation soil to support the load imposed by the wall system without shear failure or excessive settlement as depicted in Figures 4:14 and 4:15.

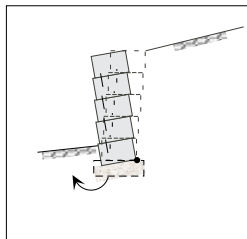

Figure 4:14 Gravity Wall Bearing Failure

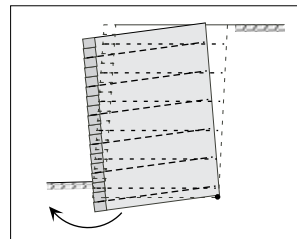

Figure 4:15 Reinforced Wall Bearing Failure

### Note:

*The live load surcharge is included as a driving force and not as a stabilizing (resisting) force. Only permanent forces within the wall are included as stabilizing forces.*





## ULTIMATE BEARING CAPACITY

The ultimate bearing capacity of the foundation is a function of the soil shear strength ( $\phi$  and  $c$ ), the embedment depth below grade, and the bearing surface's effective width ( $B-2e$ ) in accordance with the equation and factors discussed in Part Three.

In Figures 4:12 and 4:13, overturning, the resisting moments, and the driving moments are calculated for the section being analyzed. Those moments are analyzed here again. However, since the live load surcharge (if over the structure) is a destabilizing force, it is included in the driving moment term as one of the resisting reactions. The external driving moments remain the same. The equations previously provided in Part Three and Figure 3:5 provide the calculated applied bearing pressure,  $\sigma_v$ , and the equivalent footing width,  $B-2e$ .

A minimum 2.0 (NCMA) or 2.5 (AASHTO) factor of safety is required for bearing capacity for reinforced soil wall systems in ASD analysis. A  $CDR > 1.0$  is required in LRFD analysis based on a resistance factor of 0.65.

A second criteria for bearing capacity is settlement. Settlement, particularly differential settlement, should be evaluated by a qualified engineer. For reinforced soil systems, maximum allowable differential settlement is limited to 1% (NCMA) or 1/2% (FHWA). Settlement is evaluated on a service state basis ( $RF$  and  $LF = 1.0$ ) in LRFD analysis.

## INTERNAL STABILITY ANALYSIS

Internal stability is the ability of the reinforced mass to maintain its structure and resist the applied loads without deforming or failing. For a concrete cantilever wall, internal stability is provided by a combination of the stems bending and shear resistance at the footing and up the stem. In a crib or gabion system, internal stability is the dead weight and ability of each lift to resist sliding and overturning about the layer below. In soil reinforced wall system, it is the tensile and pullout capacity of the reinforcing elements and inter-unit shear/connection capacity that holds the potential wedge of soil in place. Sliding and shear are also evaluated internally to ensure the mass will not fail in internal shear.

The retaining wall mass, or structure, is composed of the Keystone units at the face combined with reinforcing elements extending back beyond the Coulomb or Rankine failure plane.

### The Elements of Internal Design are to ensure:

- 1) The tensile elements do not exceed their working stress or factored resistance limits.
- 2) The tensile elements have adequate connection capacity to the Keystone units.
- 3) The tensile elements have adequate anchorage beyond the potential failure plane to hold the wedge of soil in place.
- 4) There is not a potential surface where the mass can shear internally.
- 5) The facing is stable against potential shear, bulging, and overturning.

**Note:**

*Rigid footing systems typically require a bearing capacity safety factor of 3.0 or lower resistance factors.*



## TENSILE CAPACITY

Tensile failure occurs when the long-term design strength of the reinforcement is exceeded and leads to tensile failure of the elements. A factor of safety, or load resistance factor, is incorporated into the design to keep the calculated applied stress safely below the rupture limit.

A factor of safety is typically applied as a reduction to the Long-Term Design Strength (LTDS) of the reinforcement in allowable stress design. In Limit State Design, load factors increase the applied loads and masses above their actual values and compare to the LTDS, similar to AASHTO LRFD. Both methods achieve essentially similar results. The load factor design method allows factoring of various applied loads (i.e., live load versus dead load) and materials by factors, depending on their variability and potential effect on the design.

Using the concept of “the sum of the parts equals the whole,” theoretical earth pressure stresses in each element can be isolated and calculated as an applied load. The “whole” in this case is the total internal stress within the reinforced zone. The internal pressure for earth pressure and surcharge are superimposed on the reinforcement levels as shown in Figure 4:16 using similar Coulomb and Rankine earth pressures as calculated for the reinforced soil type:

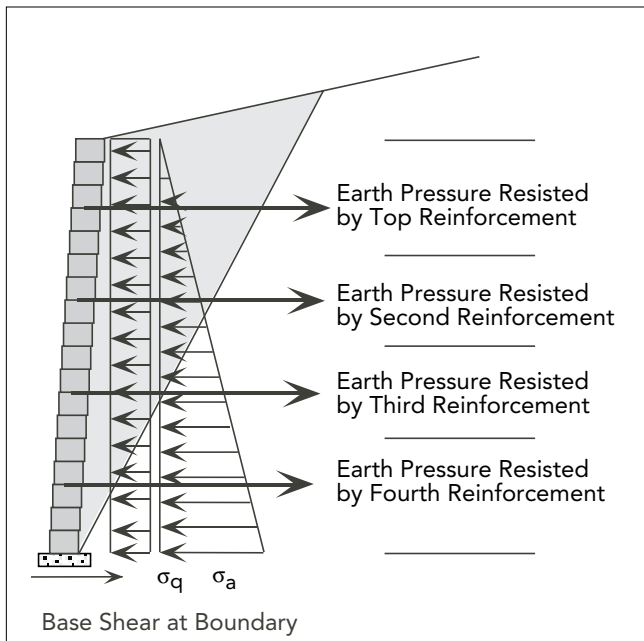

Figure 4:16 Internal Stress Distribution



## TENSION LEVEL CALCULATION

Each individual reinforcement level can be broken down into respective tributary areas as shown in Figure 4:17.

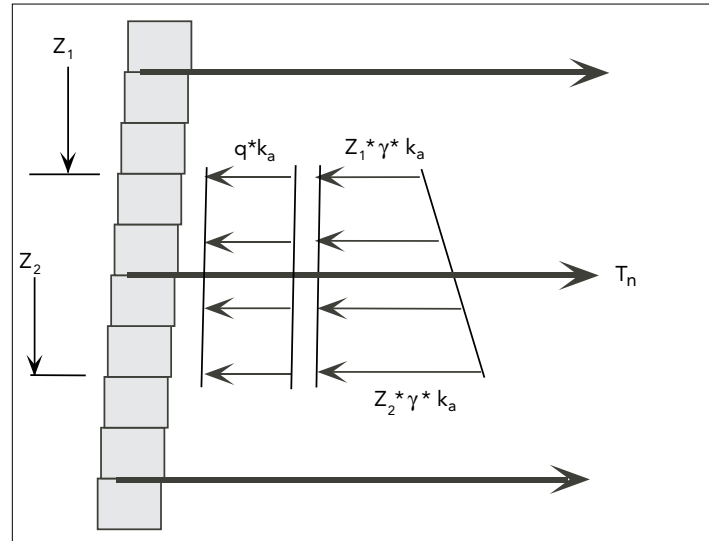

Figure 4:17 Tension Level Calculation

The internal horizontal pressure for surcharge and earth pressure are applied to the tributary area of each reinforcement. A simple equation can be set up that calculates the load per length of wall per reinforcement layer:

**Equation (4h)**  $T_n = ((Z_1 + Z_2)/2 \times \gamma \times k_a + q \times k_a) \times (Z_2 - Z_1)$  - Coulomb, Rankine, AASHTO

**Equation (4i)**  $T_n = (E V_d (Z_1 + Z_2)/2 \times \gamma \times k_a + E V_d \times q \times k_a) \times (Z_2 - Z_1)$  - AASHTO LRFD

The calculated tension in each layer of reinforcement should be less than the maximum allowable design strength,  $T_{al}$ , of the specified reinforcement type at that level, allowable stress or LRFD.



## AASHTO INTERNAL TENSION

The consensus in the present AASHTO codes is that extensible reinforcement permits enough strain (less stiffness) to permit simple active earth pressure design in accordance with Rankine Earth pressure theory.

AASHTO currently follows a “simplified” method for all reinforcement systems that still utilizes simple Rankine earth pressure methods, but treats a sloping backfill as an equivalent uniform surcharge on a level backfill, per Figure 4:18.

The internal design for a sloping backfill calculates the internal earth pressure coefficient,  $k_a$ , for a level backfill condition and then adds the average equivalent surcharge for the sloping fill on top of the wall. This analysis tends to increase the load near the top of wall and reduces the load near the bottom. KeyWallPRO permits AASHTO design methods. AASHTO LRFD 2010 and 2015 use the equivalent surcharge method for slopes. External stability computations remain the same for all methods.

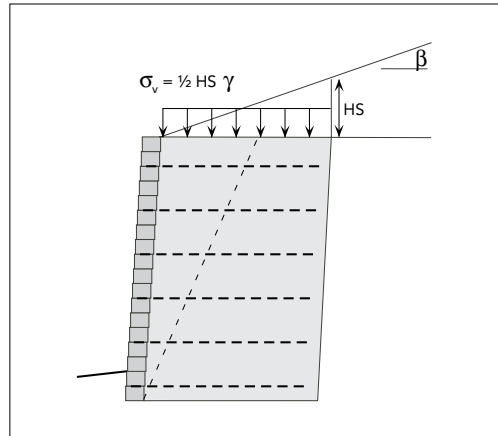

Figure 4:18 AASHTO Simplified Model

## CONNECTION CAPACITY

As stated in Part Three, the tensile load in the reinforcing may be limited by 1) Tensile capacity of the reinforcing based on material strength or 2) Connection capacity at peak connection load.

To check the connection capacity at any level, determine the capacity of the reinforcing-unit connection as a function of the normal force,  $N$ , as limited by the hinge height criteria. The normal force,  $N$ , is equal to:

$$\text{Equation (4j)} \quad N = h_i \gamma_{\text{unit}} W_u$$

where:

- $h_i$  = depth to unit or hinge height, whichever is less
- $\gamma$  = unit weight of the Keystone unit
- $W_u$  = width of the Keystone unit

The designer must refer to the laboratory test curves to determine the connection capacity based on the unit and reinforcing type. All tensions should be below the connection capacity,  $T_{\text{conn}}$ , as determined from the curves and discussed in Part Three of this manual.



## PULLOUT CAPACITY

Pullout capacity is the amount of available reinforcing pullout force to withstand the outward forces of the soil wedge. The length of the reinforcing behind the Coulomb or Rankine failure plane is defined as the embedment length. As the failure plane approaches the top of the wall system, the embedment length beyond the failure plane is reduced to the point where the reinforcement may have to be longer than the lower levels to achieve adequate pullout resistance.

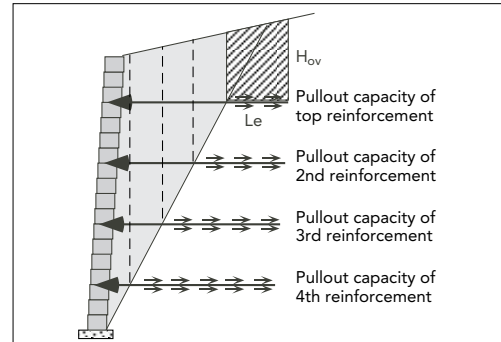

Figure 4:19 Pullout Diagram

Pullout capacity is checked at each reinforcing layer by calculating the average overburden height,  $H_{ov}$ , and the embedment length,  $L_e$ , per Figure 4:19 with the appropriate earth pressure theory. The formula for calculating the pullout resistance is defined as follows:

$$\text{Equation (4k)} \quad \text{Pullout} = (2L_e)(\gamma H_{ov})(\text{Tan } \phi C_i)$$

$$\text{Pullout} = \alpha (2L_e)(E V_r \gamma H_{ov})(\text{Tan } \phi C_i) \text{ AASHTO LRFD}$$

where:

- $L_e$  = length of reinforcing beyond the Coulomb or Rankine failure plane
- $\gamma H_{ov}$  = average vertical pressure on the reinforcing in the pullout zone
- $\text{tan } (\phi)$  = shear strength of soil
- $C_i$  = interaction coefficient of the reinforcing
- $\alpha$  = scale effect correction factor

The “2” multiplier is included since the reinforcing is providing pullout resistance from both sides, (i.e., above and below) and is how the  $C_i$  coefficient is evaluated.

The pullout capacity is checked at all reinforcing layers. The factor of safety for pullout is given as:

$$\text{Equation (4l)} \quad \text{FS}_{\text{pullout}} = \text{Pullout Resistance} / \text{Geogrid Load}$$

Alternatively, AASHTO LRFD computes a pullout capacity demand ratio:

$$\text{Equation (4m)} \quad \text{CDR}_{\text{PO}} = \text{Pullout Resistance (factored)} / \text{Geogrid Load (factored)}$$



## PULLOUT CAPACITY (continued)

The AASHTO LRFD pullout resistance factor,  $RF_{po} = 0.90$ . As is always the case in LRFD, the minimum pullout capacity demand ratio is 1.0.

If a layer of grid is failing in pullout, the designer may insert additional layers of reinforcement, increase the grid length(s), or lower the upper most layer of reinforcing to provide more overburden pressure.

NCMA recommends that all reinforcement extend a minimum of 1 foot (300mm) beyond the theoretical failure plane. AASHTO recommends a 3 foot (1m) minimum embedment length.

## STABILITY OF FACING

Inter-unit shear capacity is discussed in Part One, as a resisting force when looking at sliding failures along the reinforcing planes.

In gravity wall design, inter-unit shear is the only resisting force holding the wall from sliding at any elevation above the base.

In reinforced structures, the stability of the facing must be checked for crest toppling above the top geogrid level and adequate shear resistance at the reinforcement levels. Figure 4:20 below shows the local stability loading condition that is analyzed by the KeyWallPRO program. The inter-unit shear capacity of the units is a function of overburden height ( $N_1$  or  $N_2$ ). This resistance is compared to the maximum shear at each reinforcement connection,  $(T_1$  or  $T_2)/2$ .

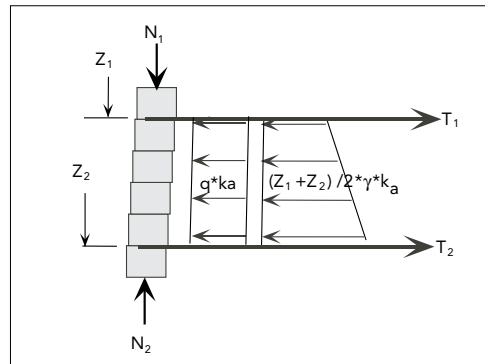

Figure 4:20 Shear and Bulging Stability

The factor of safety of shear at a unit interface should be greater than 1.5 or a CDR > 1.0 in LRFD analysis.

# PART FIVE

## KEYWALL® PRO OPERATING INSTRUCTIONS

*Children's Hospital, Highlands Ranch, Colorado; Keystone Compac® - Straight Split*

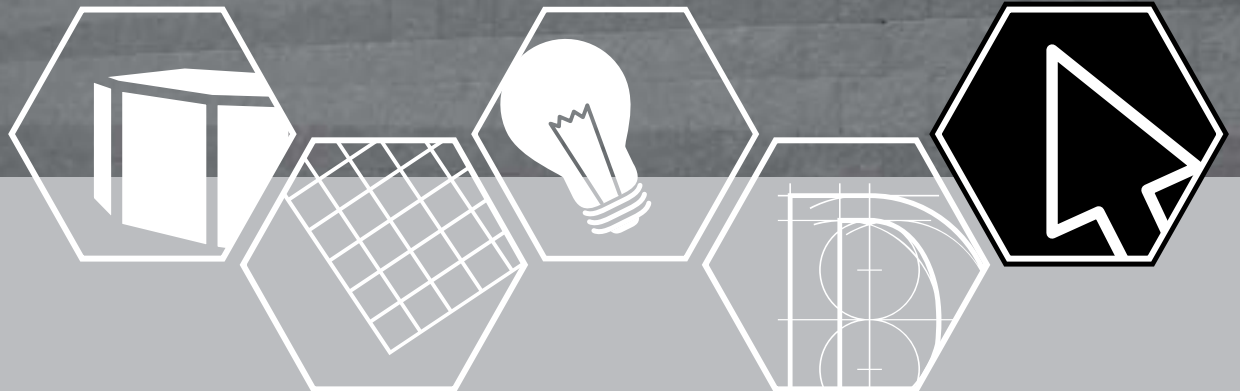



## INSTALLATION & USER'S GUIDE

**K**eyWallPRO design software is currently available as a Windows™ software program that will run under Windows 7, 8 and 10 operating systems. Mac users should use PC software such as Parallels™ to run KeyWallPRO.

KeyWallPRO takes user-defined station/elevation, geometry/surcharge information and soils information to complete full wall designs including wall profiles, geogrid locations and depths. KeyWallPRO will output the estimated wall quantities including block area, cap area, geogrid area and backfill volume. Design calculations can be printed in PDF format. A dxf file of the wall envelope, sections and quantities can also be outputted for use in CAD software.

KeyWallPRO can be used on a trial basis for a limited 14-day period. During this time period, the user will be able to utilize all design functions. The save, printing and exporting functions, however, will be disabled.

*KeyWallPRO for Windows.*

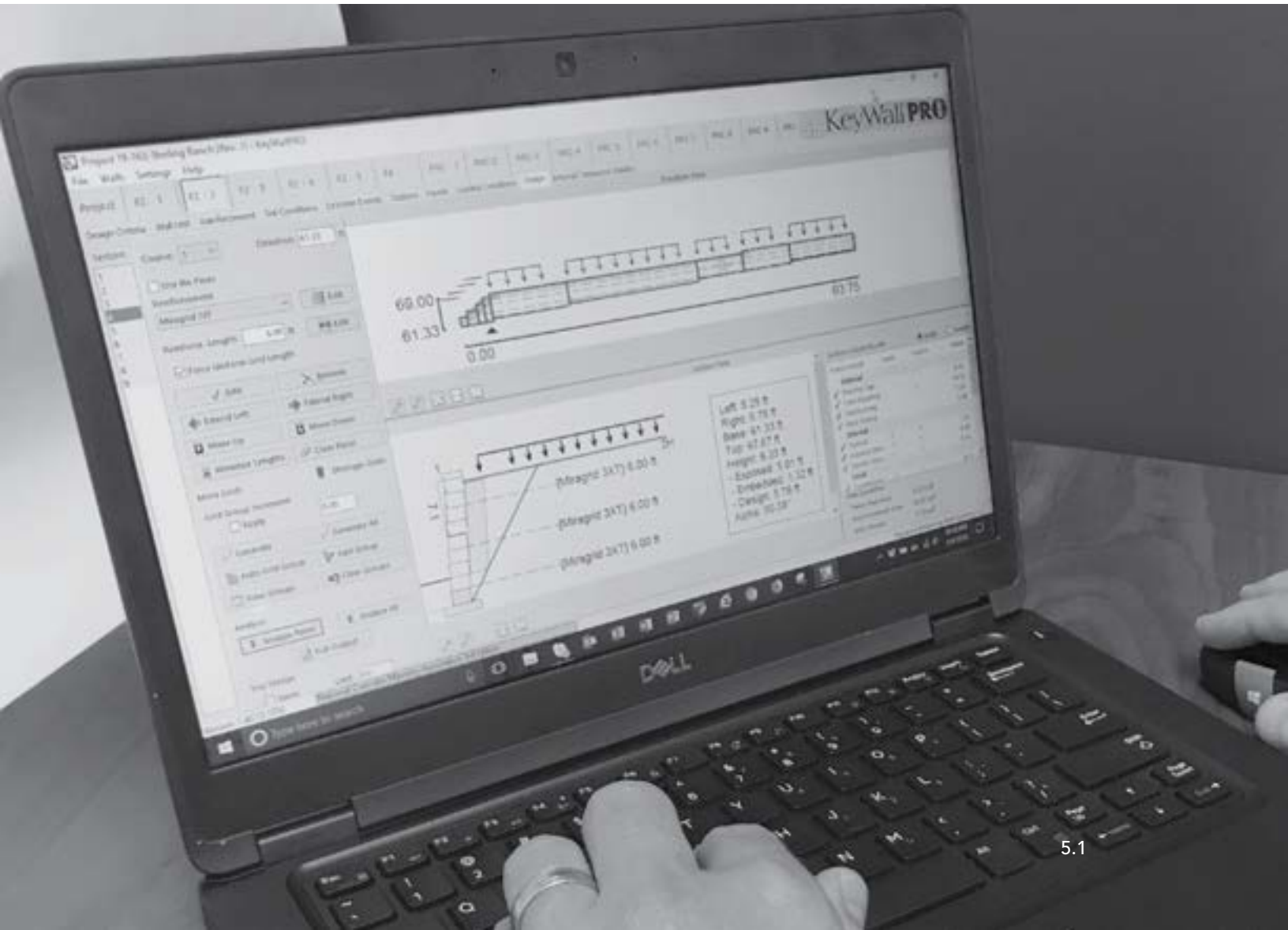





## PART FIVE

### Installation & User's Guide

## KEYWALL®PRO INSTALLATION

KeyWallPRO can be downloaded from the following link:

[www.keystonewalls.com/softwareresources](http://www.keystonewalls.com/softwareresources)

This site also includes quick start guides, additional data files and a PDF version of this software design manual. The installation steps for the Microsoft Windows 10 operating system are illustrated in the following instructions.

### Installation Instructions

- 1 Download the KeyWallPRO software installer using the download link in your web browser.



- 2 Click **Save** or **Save As** if you would like to save the **keywallprosetup** file in a specific location on your computer.

- 3 Click **Run** to initiate installation or click **Open Folder** and double click the **keywallprosetup** file to initiate installation. Windows 10 “User Account Control” will ask if you want to allow this app to make changes to your device. Click **Yes** to continue installation.

- 4 The setup window will open. Click **Next** to start installation setup.



- 5 The License Agreement window will open. Read the agreement and accept the terms by selecting “I accept the agreement”. Then click the **Next** button.

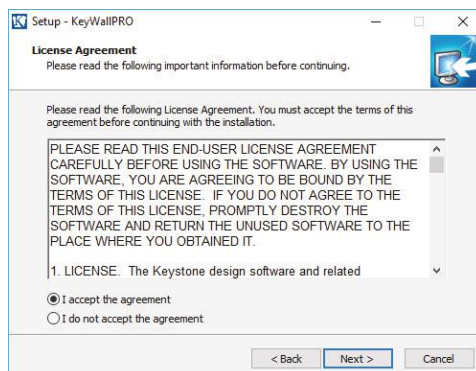



## Installation Instructions (continued)

- 6 The User Information window will open. Enter the User Name and Organization. Click **Next**.

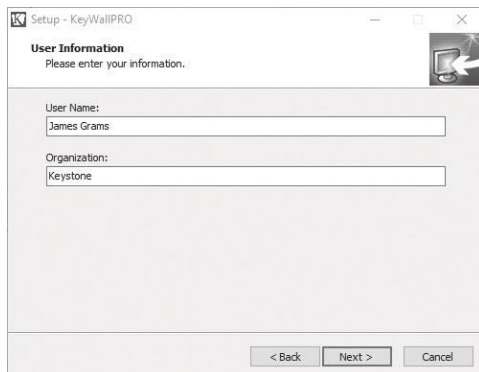

- 7 Select the file location to where KeyWallPRO will be saved on the C: drive using the **Browse** button and click **Next**. Then, click **Next** again to create the shortcuts in the KeyWallPRO file location on the Start menu (typical).

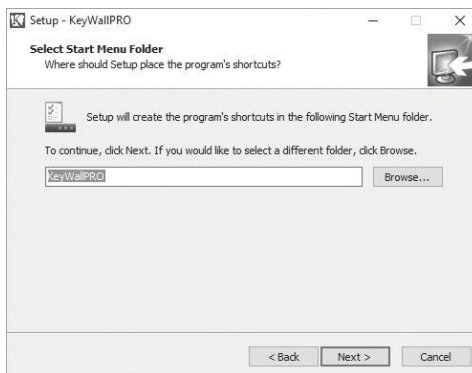
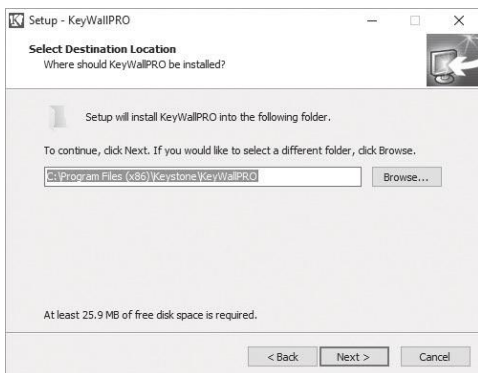

- 8 KeyWallPRO is ready to install. Click **Install** to start installing.

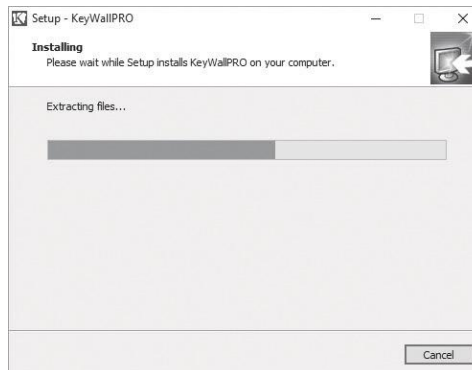
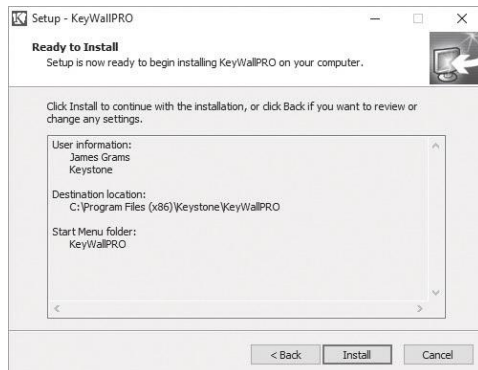



## PART FIVE

### Installation & User's Guide

#### Installation Instructions (continued)

- 9 After KeyWallPRO has finished installing, click the **Finish** button. Keep the **Run KeyWallPRO** box checked to automatically launch the program.



#### LAUNCHING THE KEYWALLPRO PROGRAM

The default KeyWallPRO installation in the Windows 10 operating system will place the KeyWallPRO program and documentation in a directory labeled “KeyWallPRO,” which resides on the following directory **C:\Program Files (x86)\Keystone**.

For easy access to the program, KeyWallPRO will place a shortcut icon on the desktop that can be used to start the program. Additionally, KeyWallPRO can be accessed from the Windows Icon (formerly Start).



## LAUNCHING THE KEYWALL®PRO PROGRAM (continued)

### Running the 14-Day Trial

KeyWallPRO is provided on a demonstration basis until registered. KeyWallPRO will not print or export dxf files in the trial mode, but the user will be able to utilize all design functions.



- 1 Click **Yes** to continue starting the program.
- 2 Click the **Begin Trial** button to start the 14-day trial.

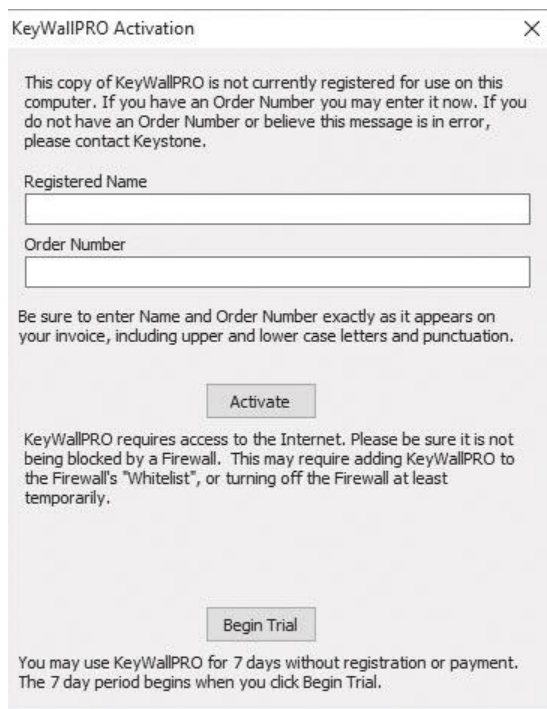

- 3 Users can choose to activate the program at some point during the trial period by registering the software.



## PART FIVE

### Installation & User's Guide

## KEYWALL®PRO REGISTRATION

Registration requires a payment of a one-time fee. The registration fee covers the third party cost to automate registration online and allows Keystone to push updates directly to users. Upon paid registration, an e-mail from support@2checkout.com will be sent with the registration code.

### Purchase Instructions

- 1 Go to [www.keystonewalls.com/softwareresources](http://www.keystonewalls.com/softwareresources)
- 2 Click the **Click Here to Purchase KeyWallPRO Software for \$9.99 USD.** link.



- 3 The KeyWallPRO software will be in your shopping cart. Enter your billing information and payment option. Then click the green **Continue** button.

The screenshot shows a checkout page with three steps: 1. Billing Information, 2. Confirmation and Payment, and 3. Finish. The 'Products in your shopping cart' section displays one item: KeyWallPRO, priced at \$9.35. Below the cart, there is a checkbox for 'I have a discount coupon' and a total price of \$9.99 with a tax of \$0.64. Payment options include Visa, PayPal, Discover, and American Express. The 'Billing Information' section is currently active, showing fields for 'Licensed to:' (Person or Company), 'First name\*', 'Last name\*', 'Address\*', 'City\*', 'Zip or postal code\*', 'Country\*' (United States of Ame...), 'State or province\*' (Minnesota), 'Phone number\*' (with a note that it will be used only if email contact fails), 'Email\*', and 'Confirm email\*'. The 'Payment Options' section includes fields for 'Billing currency\*' (USD - United States Dollar), 'Card number\*', 'Card expiration date\*' (Month and Year dropdowns), 'CW2/CVC2 code\*', and 'Card holder name\*'. A 'Continue >' button is located at the bottom of the page.



## Purchase Instructions (continued)

- 4 A confirmation page of the payment details will open. Click the green **Place Order** button to purchase the software. After the purchase is complete, the order number issued will become the registration code for the program to validate current registration. Registration will enable all KeyWallPRO functions.

Progress: 1 Billing Information (checked) 2 Confirmation and Payment (active) 3 Finish

**Products/Services**

1 x KeyWallPRO	\$9.29
----------------	--------

The billing currency is USD (\$) Total price: \$9.99  
Total TAX (7.525%): \$0.70

**Billing/Delivery information**

<b>Billing address</b> (Edit information) James Grams 4444 West 78th St Minneapolis, Minnesota, 55435 United States of America Phone number: 952-837-8201 Email: jgrams@keystonewalls.com Payment method: Visa/MasterCard	<b>Delivery address</b> (Edit information) James Grams 4444 West 78th St Minneapolis, Minnesota, 55435 United States of America
--	---

**Review and Place Order**

Your information is encrypted and sent to the server over a secure connection

Card number: \*\*\*\*\*1234  
Card expiration date: 02/2021  
CVV2/CVC2 code: \*\*\*  
Card holder name: Pat Stiemke  
[Edit information](#)

Amount: **\$9.99**

I agree to have my account charged with the amount listed above.  
By placing this order you agree to the Terms and Conditions.

Progress: 1 Billing Information (checked) 2 Confirmation and Payment (checked) 3 Finish (active)

Thank you for your order! (Order no. 12345678)

**Your purchased products**  
1 x KeyWallPRO  
**Total price:** \$9.99

We have just sent you an order confirmation email at **(customer email)**  
**Please check your mailbox (spam/junk folder included).**

As soon as your order is approved, you will receive your payment receipt via email.



## KEYWALL®PRO REGISTRATION

### Purchase Instructions (continued)

- 5 The purchaser will receive a confirmation e-mail receipt with the registration number similar to below:

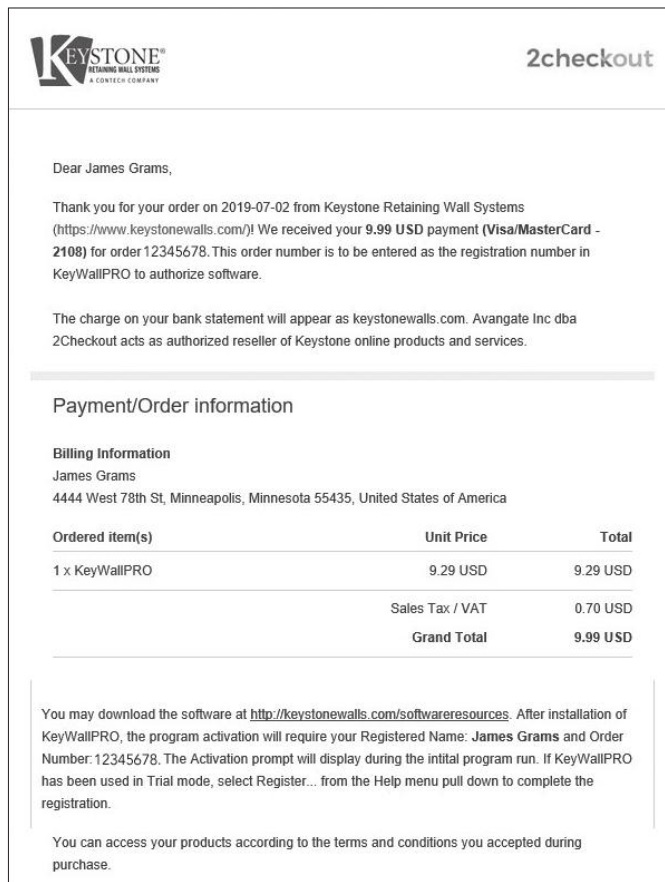

- 6 Use the order number to register the KeywallPRO software. This can be done before, during or after the trial period. You will be prompted to register the program upon starting an unregistered copy of the program. KeywallPRO activation can also be accessed through the Help menu.

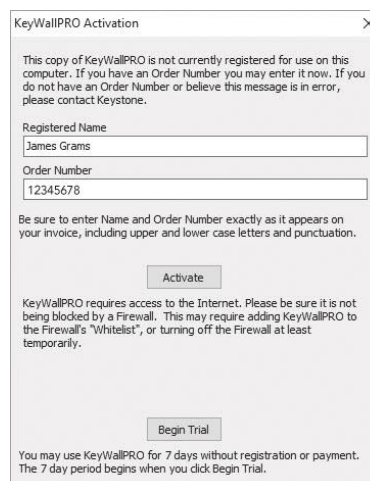
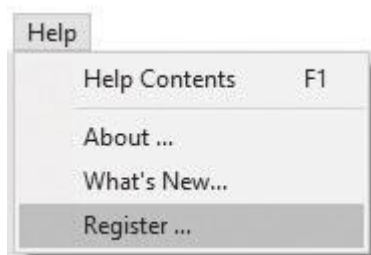



### Purchase Instructions (continued)

- 7 A correct order number corresponding to the registered name will open a window indicating a successful activation.







## KEYWALL®PRO WINDOWS INTERFACE

### FILE Menu

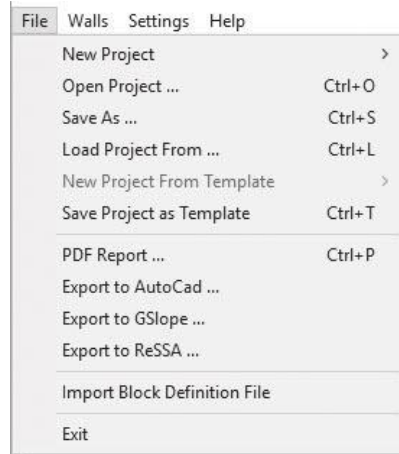

### New Project → New Wall Section Analysis

To design user-defined individual wall sections (like the previously supported KeyWall) select **New Wall Section Analysis**. Walls can be created with multiple analysis sections for each wall.

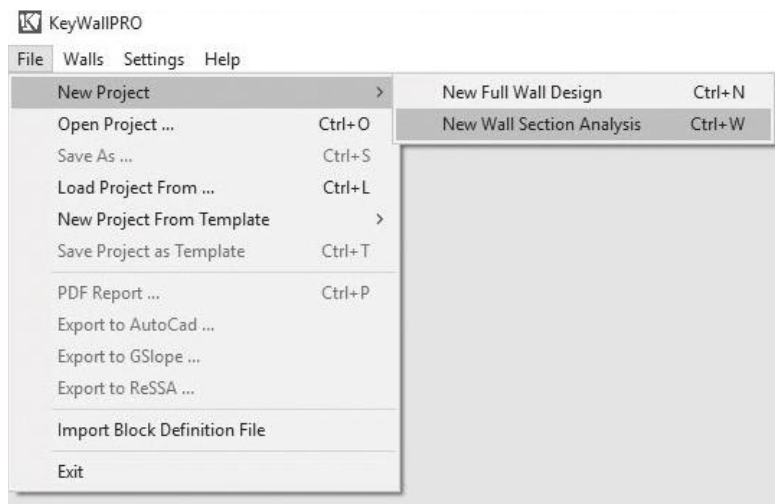



## New Project → New Full Wall Design

To complete a full design including wall profile and analysis sections (like previously supported Keydraw) select **New Full Wall Design**. The user can enter top of wall and bottom of wall points, backslope geometry and loading conditions. KeyWallPRO will panelize, design all the various wall panels and produce total wall quantities. Additional walls may be added for multiple wall projects.

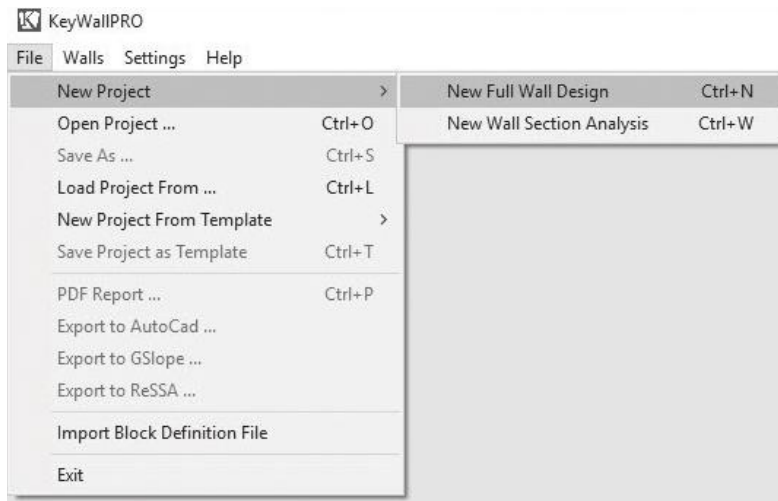

## Open Project

Select **Open Project** to open KeyWallPRO projects previously worked on. When selected, the project window will come up, allowing the user to search by client or keyword.

## Save As

Select **Save As** to save a backup file of the project to any location. Project will be saved with a .vks suffix.

## Load Project From

Select **Load Project From** to load a project from a backup file (.vks suffix) or from a backup file created on another computer.

## New Project from Template

Start a **New Full Wall Design** or **New Wall Section Analysis** from a saved template containing key design settings.

## Save Project as Template

Select **Save Project as Template** to save a project with specific design settings to be a template for future projects.



## KEYWALL®PRO WINDOWS INTERFACE (continued)

### PDF Report

Print a PDF report of selected project information including design input, section geometry, and analysis results.

Report Options

Wall/Sections

▼ 1

- 1. Stations 0.00 - 1.50
- 2. Stations 1.50 - 3.00
- 3. Stations 3.00 - 33.75**
- 4. Stations 33.75 - 40.50
- 5. Stations 40.50 - 42.00
- 6. Stations 42.00 - 43.50
- 7. Stations 43.50 - 45.00

Select All

Select None

Summary Reports

- Project Materials Summary
- Section Analysis Summary

Project Information

- Details
- Comments
- Revision Comments
- Tallest Section Drawing
- Section Overview
- Quantities

Project Design Inputs

- Standards / Factors of Safety
- Wall Unit
- Soil Conditions
- Reinforcement

Section Geometry

- Station Information
- Station Drawing
- Panelization Details
- Panelization Drawing
- Markers
- Reinforcement Details

Analysis Results

- Factors of Safety Summary
- Cross-section Detail
- Cross-section Drawing
- Factors of Safety
- Detailed Static Calculations
- Detailed Seismic Calculations
- ICS Static Drawing
- ICS Seismic Drawing

Select All Options

Include Preliminary Note

Save PDF Report to...

C:\Users\gramsj\Desktop\Design Manual Revision 2018\Part 5 Keywall Operation Inst\

Save Preview / Print Close

### Export to AutoCad

Export the wall sections and/or wall profiles to .dxf files to be used in AutoCad or other CAD software.

### Export to GSlope, Export to ReSSA

KeyWallPRO will output geometry to GSlope and ReSSA for additional analysis.



### Import Block Definition File

Allows the user to add additional wall units and reinforcement combinations not included in the default version of KeyWallPRO.

### Exit

KeyWallPRO uses a project file database which saves data as it is entered. Therefore, KeyWallPRO will exit without prompting the user to save a project.

## WALLS Menu

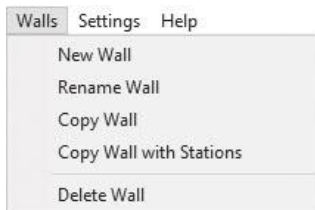

### New Wall

Select **New Wall** to create a new wall.

### Rename Wall

Select **Rename Wall** to rename an existing wall.

### Copy Wall

Select **Copy Wall** to create a new wall with the same design criteria, wall unit, reinforcement, soil conditions and seismic loading as the one currently being worked on.

### Copy Wall with Stations

Select **Copy Wall with Stations** to create a new wall that is a copy of the current wall being worked on and includes the wall stations and geometry. This allows the user to create alternate design scenarios for the same wall.

### Delete Wall

Select **Delete Wall** to delete the wall currently being worked on.

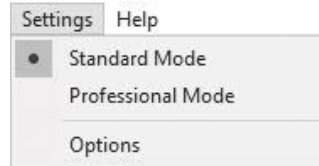
**KEYWALL®PRO WINDOWS INTERFACE** (continued)**SETTINGS Menu****Standard Mode**

Choose **Standard Mode** (default) to keep the design limitations imposed on the program. The intent is to discourage misuse of the KeyWallPRO software.

**Professional Mode**

Choose **Professional Mode** to disable the design limitations imposed on the program. This option is only recommended for engineers with experience designing Keystone walls. Professional mode will disable the design limitations for:

- AASHTO uniform geogrid depth
- Geogrid parameters on reinforcement tab
- Friction angle, cohesion, and unit weight on soil conditions tab
- Crest and toe slopes on stations tab
- Top of wall within 2 feet of profile grade, leveling pad base dimensions, and batter on wall unit tab
- Slope angle and live/dead loads on loading conditions tab

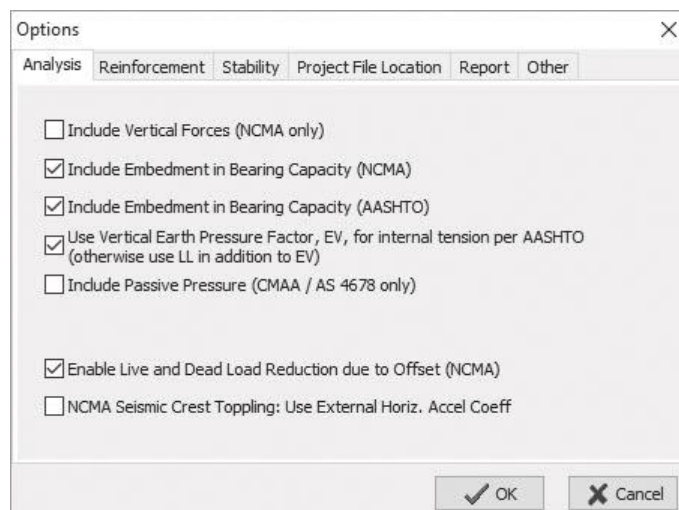
**Options → Analysis****Include Vertical Forces (NCMA only)**

Check this box to include the vertical force component from the soil and dead load surcharge as resisting forces in the sliding and overturning calculations. Applies to NCMA designs only.

**Include Embedment in Bearing Capacity (NCMA)**

Check this box to increase the calculated bearing capacity by including embedment when using the NCMA design methodology.



Options → Analysis (continued)

**Include Embedment in Bearing Capacity (AASHTO)**

Check this box to increase the calculated bearing capacity by including embedment when using AASHTO design methodologies.

**Use Vertical Earth Pressure Factor, EV, for internal tension per AASHTO**

Check this box to use the vertical earth pressure load factor (EV) when calculating internal pressure. The program uses the horizontal earth pressure load factor (EH) by default. This applies to the AASHTO LRFD design methods.

**Include Passive Pressure (CMAA / AS 4678 only)**

Check this box to include the passive earth pressure that is applied to the embedded portion directly in front of the wall. This applies to the CMAA / AS 4678 design methods.

**Enable Live and Dead Load Reduction Due to Offset (NCMA)**

The NCMA design methods do not allow offset live and dead load surcharges. Check this box to reduce the live and dead loads as they are offset further from the back of the wall using a trial wedge analysis. All other design methods will automatically reduce live and dead load surcharges for offset.

**NCMA Seismic Crest Toppling: Use External Horiz. Accel Coeff**

Check this box to use the external horizontal acceleration coefficient when calculating seismic crest toppling using the NCMA design method. The external horizontal acceleration is half the internal horizontal acceleration.

Options → Reinforcement

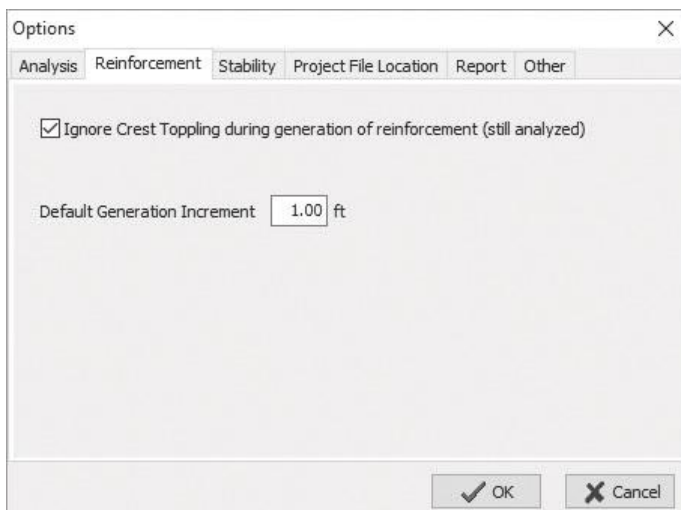

**Ignore Crest Toppling during generation of reinforcement (still analyzed)**

Crest toppling can fail due to surcharge loads analyzed directly behind the top of the wall. However, in situations where copings and barriers are proposed at the top of the wall, crest toppling may not be a valid concern. Check this box to ignore crest toppling when determining the geogrid layout. It will still be analyzed and noted when crest toppling does not pass. The user can then make the determination on whether this crest toppling result should be a concern.

**Default Generation Increment**

Specify the geogrid length increment which KeyWallPRO uses to determine the length of geogrid to test.



## KEYWALL®PRO WINDOWS INTERFACE (continued)

### Options → Stability

The Internal Compound Stability (ICS) parameters are specified here.

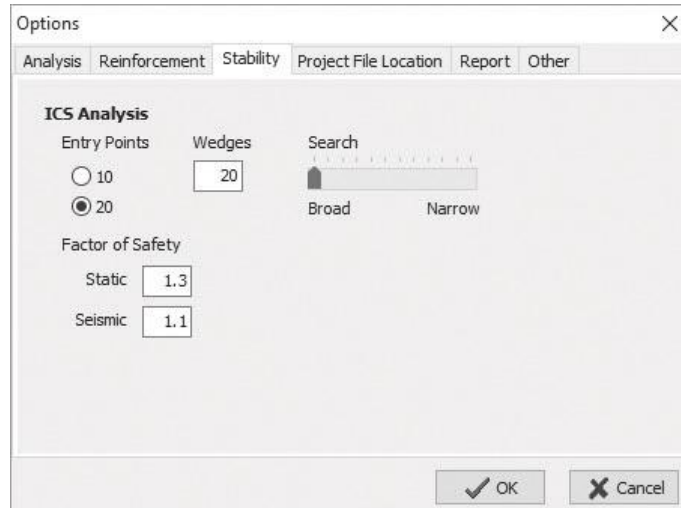

#### ICS Analysis

##### Entry Points

Specify whether you want 10 or 20 entry points.

##### Wedges

Specify the number of wedges.

##### Factor of Safety

Specify the static and seismic factors of safety used in the ICS Analysis.

### Options → Project File Location

Sets the default folder path location on the project screen. Users must click on **Set/Change** button to populate the folder path cell.

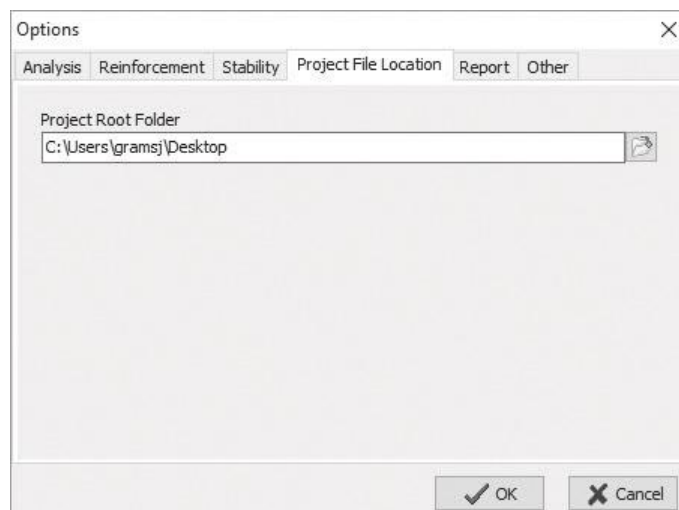



Options → Report

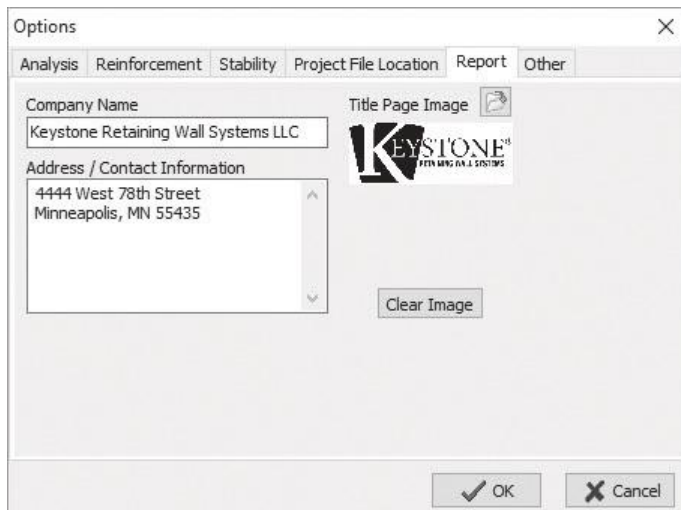

**Company Name**

Enter company name to have it printed on the output reports.

**Address / Contact Information**

Enter the company address and contact information to have it printed on the output reports.

**Title Page Image**

Use the button next to **Title Page Image** to specify the file location of a business logo, which will be printed on the output reports.

**Clear Image**

Use this button clear the title page image.

Options → Other

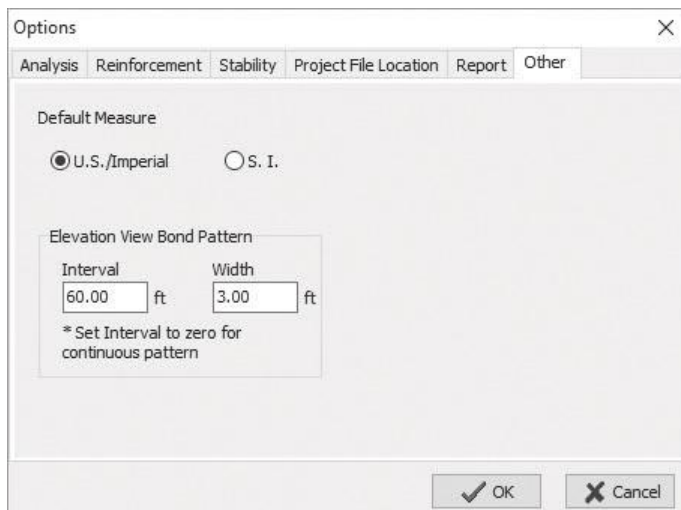

**Default Measure**

Choose the default units of measure used, **US/Imperial** or **SI (metric)** when KeyWallPRO is started.

**Elevation View Bond Pattern**

Choose the interval and width of vertical block columns to be drawn. Set the interval to zero for KeyWallPRO to draw all the wall units.





## PART FIVE

### Installation & User's Guide

## KEYWALL®PRO WINDOWS INTERFACE (continued)

### HELP Menu

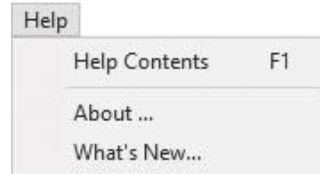

#### Help Contents

Contains local help files.

#### About

KeyWallPRO version and registration information is here. Note, the registration number is only a reference number. It is not the same number provided by 2checkout to allow KeyWallPRO to be registered.

#### What's New...

Opens a KeyWallPRO version history PDF document.

#### Note:

You must specify a client, project name, methodology, and project file folder path **BEFORE** clicking the "Create Wall" button.

### PROJECT Screen

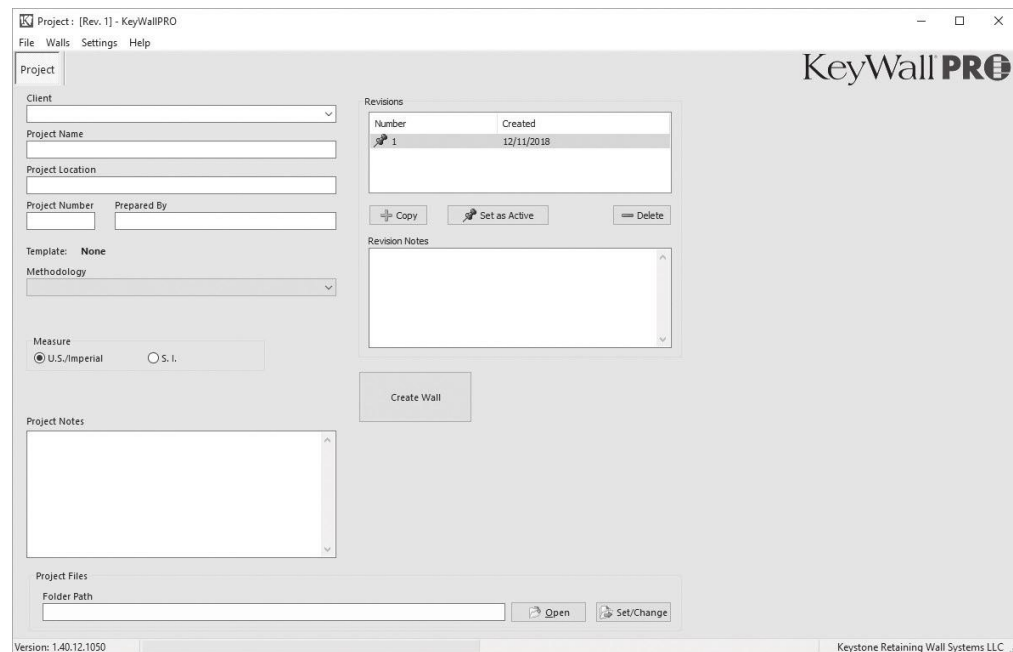

#### Client

To start a project, enter a **client name** or choose a **client** from the populated list of previously entered clients. KeyWallPRO saves projects to an internal database in real time. The files are sorted by client name.

#### Project Name, Project Location, Project Number, Prepared By

Enter the project information in these fields.



## PROJECT Screen (continued)

### Methodology

Choose a design methodology: includes AASHTO 2010 (LRFD), AASHTO 2015 (LRFD), AS 4678 (Australia), NCMA 3rd Edition and Rankine.

### Measure

Choose the units of measure, U.S./Imperial or S.I. (metric).

### Project Notes

The user can enter notes associated with the project here.

### Project Files

The user specifies the file folder path. This is the location where KeyWallPRO saves electronic PDF output, dxf file output, and the project backup file. Users must click the **Set/Change** button to specify the folder path.

### Revisions

New projects are designated as revision number 1. To add a revision to the calculations, click the **Copy** button. The new revision will be set to the **Active** designation denoted by the red thumb tack. Users can access previous revisions by selecting the revision in the list and pressing the **Set as Active** button. The red thumb tack will move to the selected revision.

### Revision Notes

The user can enter notes associated with each revision here.

### Create Wall

To start a wall, click the **Create Wall** button. A window will open asking for the wall name. Enter the wall name and click **OK**. The wall will be added to the ribbon below the menu bar.

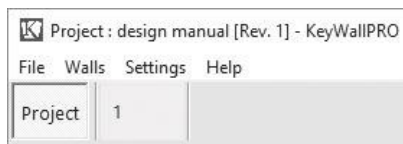
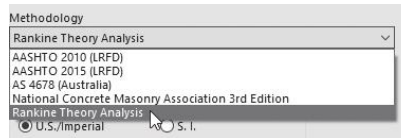

### New Full Wall Design and New Wall Section Analysis: What's the Difference?

**New Wall Section Analysis** is for designing user-defined individual wall sections. **New Full Wall Design** is for designing an entire wall from user-defined top and bottom of wall elevations and loading information. The design tabs for each mode are outlined below:

#### Full Wall Design

- Design Criteria
- Wall Unit
- Reinforcement
- Soil Conditions
- Extreme Events
- Stations (Wall Layout Information)
- Panels (Panelized Wall)
- Loading Conditions (Geometry/Loading)
- Design (For Multiple Panels or Sections)
- Internal Compound Stability

#### Wall Section Analysis

- Design Criteria
- Wall Unit
- Reinforcement
- Soil Conditions
- Extreme Events
- Design (For One Section at a Time)
- Internal Compound Stability

Each tab will be discussed. Some tabs are the same for either design mode.

#### Note:

*Because KeyWallPRO stores all project data on your C drive, it is important to back up your computer and or back up your project file to the folder path specified.*



## KEYWALL®PRO WINDOWS INTERFACE (continued)

### DESIGN CRITERIA Tab

**Note:**

*Empirical checks can be modified for special design scenarios. Some examples include: 2-block geogrid spacing, location of base or top geogrid, reducing the minimum 8' geogrid length to 6' as allowed by AASHTO, and other design criteria the user wants to relax at their discretion.*

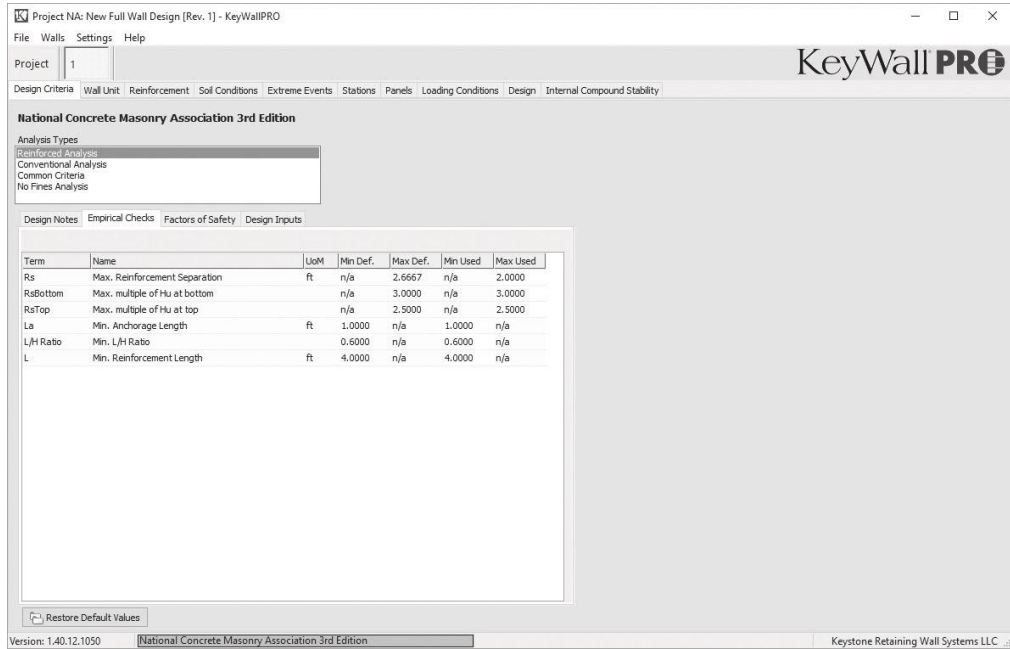

### Empirical Checks for Reinforced Analysis

- Rs** - The maximum vertical separation between reinforcement layers
- RsBottom** - The maximum distance from the bottom of the wall to the lowest geogrid layer, in units
- RsTop** - The maximum distance from the top of the wall to the uppermost geogrid layer, in units
- La** - The minimum anchorage length or length of reinforcement past the failure plane
- L/H Ratio** - The minimum reinforcement length to wall height ratio
- L** - The minimum reinforcement length



### Empirical Checks for Common Criteria

- MinHemb** - The minimum embedment below grade
- Hemb** - The minimum embedment below grade as a percentage of the wall height
- Hemb2** - The minimum embedment at 3:1 toe slope areas below grade as a percentage of the wall height

**Note:**

*KeyWallPRO will allow the user to create panels that have embedment LESS than this criterion, but the analysis will flag those panels.*



DESIGN CRITERIA Tab (continued)

Term	Name	UoM	Min Def.	Max Def.	Min Used	Max Used
No Fines Depth	Min. No Fines Depth	ft	1.0000	n/a	1.0000	n/a
No Fines L/H Ratio	Min. No Fines L/H Ratio		0.4000	n/a	0.4000	n/a

Empirical Checks for No Fines Analysis

**No-Fines Depth** - The minimum depth of the no-fines concrete as measured from the wall face

**No-Fines L/H Ratio** - The minimum no-fines depth-to-wall height ratio

**Note:**

*See no-fines concrete design section on page 4.6.*

Factors of Safety for Reinforced Analysis (NCMA & Rankine)

Category	Term	Name	Default	Used
External	FSsl	Base Sliding	1.50	1.50
External	FSbc	Bearing Capacity	2.00	2.00
External	FSct	Crest Toppling	1.50	1.50
External	FSot	Overturning	2.00	2.00
Internal	FSsl	Internal Sliding	1.50	1.50
Internal	FSpO	Pullout	1.50	1.50
Internal	FSto	Tensile Overstress	1.50	1.50
Local	FSCS	Connection Strength	1.50	1.50
Local	FSsc	Facing Shear	1.50	1.50

Load and Resistance Factors for Reinforced Analysis (AASHTO LRFD 2010 & 2015)

Term	Name	Min Def.	Max Def.	Min Used	Max Used
LFDC	Load - Dead Load (Structure)	0.90	1.25	0.90	1.25
LFES	Load - Earth Surcharge Load	0.75	1.50	0.75	1.50
LFEH	Load - Horz. Pressure of earth fill	0.90	1.50	0.90	1.50
LFCT	Load - Vehicular Collision Force	0.00	1.00	0.00	1.00
LFLL	Load - Vehicular Live Load	0.00	1.75	0.00	1.75
LFEV	Load - Vert. Pressure of earth fill	1.00	1.35	1.00	1.35
BEARING	Resistance - Bearing	0.65	n/a	0.65	n/a
TCONN	Resistance - Connection	0.90	n/a	0.90	n/a
PULLOUT	Resistance - Pullout	0.90	n/a	0.90	n/a
SLIDING	Resistance - Sliding	1.00	n/a	1.00	n/a
TAL	Resistance - Tensile	0.90	n/a	0.90	n/a



**Note:**  
*Fields in white  
can be edited. Use  
professional mode to  
unlock some fields for  
editing.*

## WALL UNIT Tab

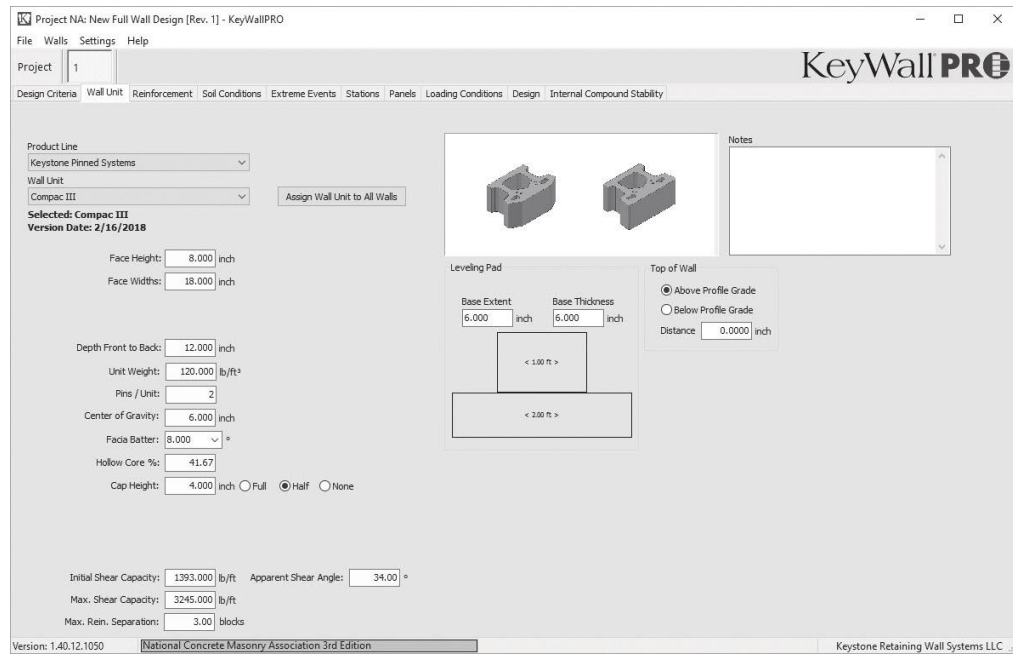

### Product Line

The user selects the type of Keystone units to design with, either the Keystone pinned or the lip/lug system units.

### Wall Unit

The user selects the Keystone unit to design with. Most of the unit information will appear in the fields below.

### Facia Batter

The user selects the **facia batter**. A dropdown list will display the available batter choices for the selected unit. For a near-vertical walls a 0 degree batter is conservatively used. A custom facia batter angle can be entered. However, pin location, rear lip size and lug location will determine batter.

### Cap Height

The user selects the cap by clicking the correct radio button: **Full height**, **Half height** or **None**.

### Leveling Pad

The user selects the leveling pad dimensions. This geometry is reflected in printouts and the calculations.

### Top of Wall

The user can set block stepping above or below the profile grade line and also specify the offset in inches. This is useful for freeboard or concrete coping situations.



## REINFORCEMENT Tab

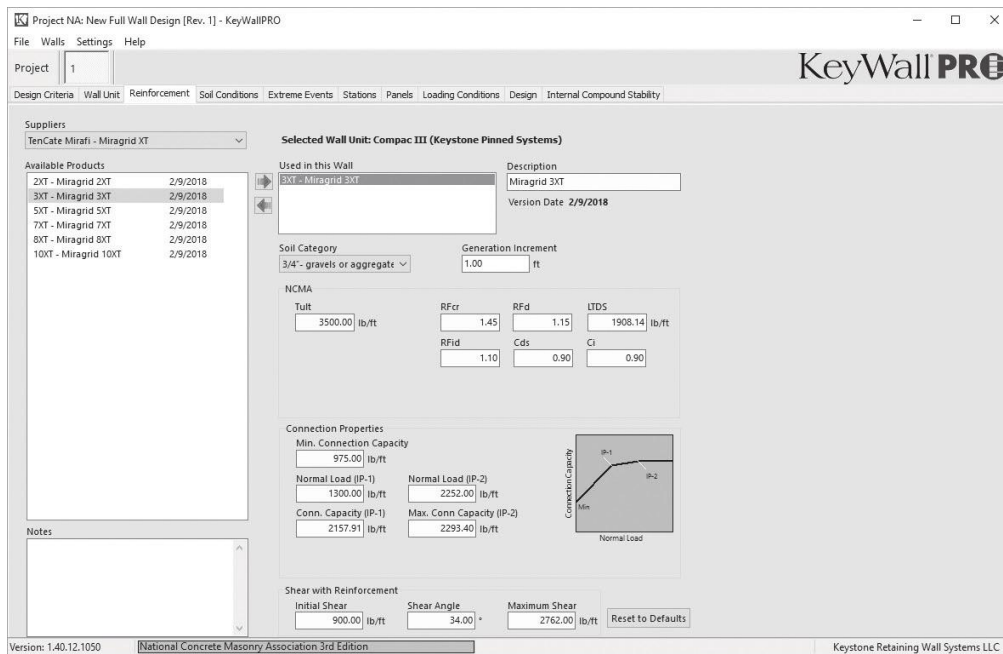

**Note:**

*Fields in white can be edited. Use professional mode to unlock some fields for editing.*

### Suppliers

The user selects the soil reinforcement supplier to design with.

### Available Products

A list of available products (reinforcements with connection testing data) will appear.

### Used in This Wall

The user selects the specific soil reinforcement product that will be used in the design by double clicking the product or highlighting the product and clicking the appropriate green arrow. They will appear in the **Used in this Wall** list. The user can remove a reinforcement by double clicking it. The strength, connection and shear data will appear for the highlighted soil reinforcement in the fields on the right side of the screen.

### Soil Category

The user selects the appropriate reinforced soil type to determine the  $RF_{id}$ ,  $C_{ds}$  and  $C_i$  values.

### Generation Increment

The generation increment is the length increment of soil reinforcement that KeyWallPRO uses for automated design. KeyWallPRO will change the design reinforcement lengths based on this value.



## SOIL CONDITIONS Tab

### Reinforced, Retained and Foundation Soil Parameters

The user enters the appropriate design soil parameters based on geotechnical data, project specifications, and/or assumed parameters based on design experience. A description of the soil can be included.

### Leveling Pad

Leveling pad friction angle and friction factor are specified here. The default values provided assume a crushed stone pad.

### Reset to Default Soils

Click this button to reset the soils to the default.

### Apply Soils to all Walls

Click this button to apply the same soil parameters to all walls.

### Reinforced Fill Cut Angle

The user can specify the cut angle (as measured from the horizontal) behind the reinforced soil zone. This will appear in the design graphic.

### Include Drainage

Check this box to include drainage elements. The default soil parameters for drain rock is typically listed. The drainage elements (when defined) will appear in the graphic to the right. Define the thickness in inches.

**Face Drain** - The drain directly behind the block column.

Specify the thickness of the impervious soil above the reinforced zone and the lowest elevation of the face drain (at Grade or at Base).

**Blanket Drain** - The drain at the base of the reinforced soil zone. Specify the thickness in inches.

**Chimney Drain** - The drain located against the back cut of the reinforced soil zone. Specify the height in inches or as a percentage of the total wall (70% default).

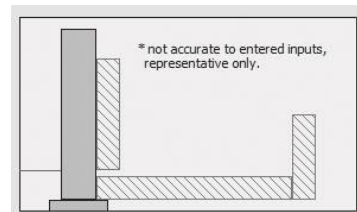

**Note:**

*Drainage options are for calculating drain rock quantities and will not factor into the design calculations.*



## EXTREME EVENTS Tab

### NCMA 3rd Edition design method

Check the **Include Seismic Analysis** for seismic design.

#### Peak Acceleration

The user enters the horizontal peak ground acceleration here. This represents the fraction of the gravitation constant  $g$  based upon a 90% probability of the value not being exceeded in 50 years.

#### Use Deflection

Check this box to allow deflection of the wall facing during an earthquake.

#### Default Deflection and Variable Deflection

The **Default Deflection** is set at 2 inches. The user can enter a different deflection by checking the **Variable Deflection** box and entering the deflection in the field to the right.

#### khext and khint Coefficient

A horizontal seismic coefficient is determined for the internal design and external design based upon formulas found in Section 9.4 of the NCMA 3rd Edition code.

### Rankine design method

Check the **Include Seismic Analysis** box for seismic design.

#### Site-adjusted Peak Ground Acceleration (As)

The user enters the horizontal peak ground acceleration adjusted for the site class as described in the most current FHWA and AASHTO design methods. KeyWallPRO calculates the peak structural acceleration:  $A_m = A_s(1.45 - A_s)$  for  $A_s < 0.45g$ .

#### kh Coefficient – Internal

KeyWallPRO uses the full peak structural acceleration,  $A_m$ , for the internal design.

#### kh Coefficient – External

KeyWallPRO uses half peak structural acceleration for the external design.





## PART FIVE

### Installation & User's Guide

#### EXTREME EVENTS Tab (continued)

##### AASHTO LRFD 2015 design method

Check the **Include Seismic Analysis** box for seismic design.

Project 1

Design Criteria Wall Unit Reinforcement Soil Conditions Extreme Events Stations Pan

Seismic

Include Seismic Analysis

Site-adjusted Peak Ground Acceleration (As)  
0.07

Allow for wall displacement

kh Coefficient  
0.07

##### Site-adjusted Peak Ground Acceleration (As)

The user enters the horizontal peak ground acceleration adjusted for the site class as described in the AASHTO 2015 design method.

##### Allow for Wall Displacement

Check this box to allow deflection of the wall facing during an earthquake. Allowing displacement will cut the kh coefficient in half.

#### STATIONS Tab (Full Wall Design Only)

Project NA: New Full Wall Design [Rev. 1] - KeyWallPRO

File Walls Settings Help

Project 1

Design Criteria Wall Unit Reinforcement Soil Conditions Extreme Events Stations Panels Loading Conditions Design Internal Compound Stability

KeyWall PRO

Crest Geometry  Toe Geometry Enter as  Elevation  Slope

Bench 0.00 ft

Station Entry Resolved Stations

Station	Top	Crest Offset	Crest Elevation
0.00	985.00		
20.00	985.00		
40.00	984.00		
44.00	983.00		

Station	Bottom	Toe Offset	Toe Elevation	Embed.
0.00	984.50			calc
4.00	980.00			calc
40.00	980.00			calc
44.00	983.00			2.00

Elevation View

Version: 1.40.12.1050 National Concrete Masonry Association 3rd Edition Keystone Retaining Wall Systems LLC



**STATIONS Tab (Full Wall Design Only) (continued)**

**Station Entry**

The top of wall stations and elevations are entered into the upper table. The bottom of wall stations and elevations are entered into the lower table. The arrow keys on the keyboard can be used to move through the table and add rows.

**Crest Geometry**

The user can choose to input backslope geometry by checking **Crest Geometry** and filling in the **Crest Offset** and **Crest Elevation** fields. Alternatively, if the **Slope** radio button is selected, the **Crest Elevation** column becomes the **Crest Slope**. A value is not required for all points. The program will approximate between different slopes or assume the slope is level. The geometry will be reflected on the loading conditions tab and can still be manually edited.

Alternatively, you can simply choose to specify backslope geometry on the **Loading Conditions** tab.

**Toe Geometry**

The user can choose to enter toe geometry. This defines benches and/or slopes that occur at each point in front of the wall. The **Elevation** and **Slope** radio buttons determine if the **Crest Elevation** or **Crest Slope** is used to define the toe.

The design criteria tab, under **COMMON CRITERIA**, includes an empirical check for toe slopes steeper than 18.4 deg (3H:1V), Hemb2. For toe slopes >18.4 deg, a minimum embedment criterion of H/7 (14.28%) is utilized. Hemb2 can be increased as required by site conditions. Also, when exporting output to global stability software Gslope or ReSSA, this geometry will be included.

**Embedment**

If additional embedment is required at certain locations along the wall, the user can specify embedment at each station that is different from the typical embedment chosen on the **Panels** tab. If the embedment cell is left blank, the minimum embedment, entered on the **Panels** tab, will be used.

**Resolved Stations Tab**

On this tab the top of wall and bottom of wall points are resolved into stations and elevations in a single table that allows the detailed panelization data to be viewed.

**+Add and -Delete Buttons**

Use the **Add** and **Delete** buttons to add or delete rows.

**Import and Paste Buttons**

The user can import station data from comma or tab-separated text in the format (station, top, bottom), one point per line. Press the **Import** button to import text files. Alternatively, a minimum 3-column-wide copy of cells from an Excel spreadsheet with station data can be inserted by pressing the **Paste** button.

STA	TOW	BOW
0	985	
20	985	
40	984	
44	983	
0		984.5
4		980
40		980
44		983

**Note:**

*KeyWallPRO does not use toe geometry information for bearing capacity calculations.*

**Notes:**

*Top and bottom of wall elevations must be entered in different columns.  
Station length for both TOW and BOW must start and end on the same station.*



## PART FIVE

### Installation & User's Guide

## PANELS Tab (Full Wall Design Only)

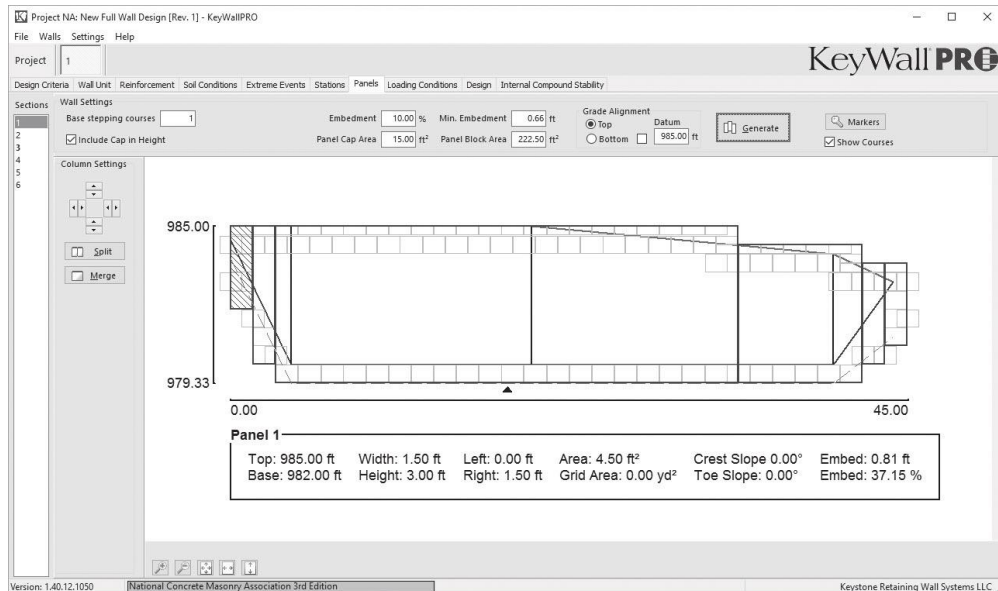

### Note:

The total **Panel Cap Area** (*cap area*) and **Panel Block Area** (*block area*) is shown above the wall envelope.

### Generate Button

When switching to the **Panels** tab, the wall envelope is already drawn using the **Stations** information and default **Wall Settings**. It is broken up into design panels at each step location. Panels can be selected graphically on the wall profile or by section number on the far left. The user can adjust the **Wall Settings** and redraw the wall envelope by pressing the **Generate** button.

Wall Settings	
<b>Base Stepping Courses</b> -	Choose the number of courses to step up or down by the bottom of wall.
<b>Include Cap in Height</b> -	Check <b>Include Cap in Height</b> to set the top of the cap at or above the top of ground line.
<b>Embedment</b> -	Choose the minimum embedment depth as a percentage of wall height.
<b>Min. Embedment</b> -	Choose the minimum embedment depth.
<b>Grade Alignment</b> -	As a default, KeyWallPRO sets the datum based on the highest or lowest elevation at the top or bottom of the wall dependent on which radio button is selected. The user can check the box to the left of the datum and specify a different datum elevation.

### Show Courses

Check this box to include drawn caps, top of wall units and bottom of wall units on the wall profile (this is checked by default).



## PANELS Tab (Full Wall Design Only) (continued)

### Markers

The user can press the **Markers** button to add information to the wall envelope, like bend, corner locations or any other items unique to the wall (if desired).

### Column Settings

The panels can be manipulated left, right, up or down by selecting the panel on the wall envelope and using the **arrows** to change the boundaries.

**Split** - The **Split** button will split a panel in two at the center.

**Merge** - The **Merge** button will merge the selected panel with the panel immediately to the right.

### Panel Information

Panel information is displayed directly below the wall envelope for each individual panel selected.

### Zoom



For larger walls, the user can zoom in on the image to see the panels that may be too small visually to select. The user can also zoom out or fit the drawing to the window horizontally, vertically or both using the buttons located in the lower left corner of the window. Use the scroll bars to see different zoomed-in parts of the wall.

## LOADING CONDITIONS Tab (Full Wall Design Only)

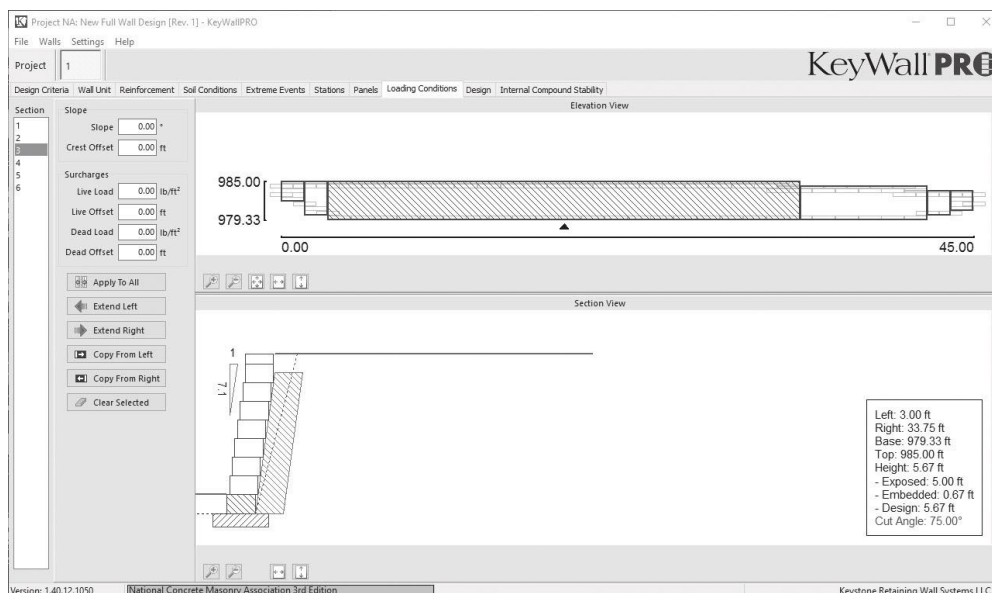

**Note:**

*The triangle and bold panel represent the tallest section.*

### Section

The panels are listed on the left side of the window. Start by selecting a panel from the list or clicking on the image. Multiple panels can be selected by holding the **CTRL** button on the keyboard. After selecting a panel or panels, the backslope geometry and surcharge loading can be specified.



## PART FIVE

### Installation & User's Guide

#### LOADING CONDITIONS Tab (Full Wall Design Only) (continued)

<b>Slope</b>	
<b>Slope</b>	- Backslope angle in degrees
<b>Crest Offset</b>	- Backslope length as measured from the back of the Keystone unit
<b>Surcharges</b>	
<b>Live Load</b>	- Live load surcharge
<b>Live Offset</b>	- Offset distance as measured from the back of the wall unit to live load
<b>Dead Load</b>	- Dead load surcharge
<b>Dead Offset</b>	- Offset distance as measured from the back of the wall unit to dead load

#### Apply to All

Select the **Apply to All** button to apply the slope and surcharge condition to all panels.

#### Extend Left and Extend Right

Select the **Extend Left** or **Extend Right** buttons to apply the slope and surcharge conditions to all panels in that direction, from the selected panel.

#### Copy From Left and Copy From Right

Select the **Copy From Left** or **Copy From Right** buttons to copy the slope and surcharge conditions from the left or right panel to the currently selected panel.

#### Clear Selected

Select the **Clear Selected** button to zero out the slope and surcharge conditions from the selected panels.

#### Section View

Displays a cross section of the panel selected. The specific data for the section is displayed on the right side of the screen.

#### DESIGN Tab (Full Wall Design)

The screenshot shows the KeyWall PRO software interface. The main window displays a cross-section of a retaining wall with a surcharge. The left-hand panel contains various controls for the design, including reinforcement settings (Miragrid 3XT, length), grid settings, and analysis options. The right-hand panel shows the 'Section 3 Quick Results' for a static analysis, including failure mode, layer, course, and value. The bottom of the interface shows the version number (1.40.12.1050) and the Rankine Theory Analysis option.

Failure Mode	Layer	Course	Value
External			
✓ Bearing Capacity			8.26
✓ Crest Toppling		6	2.29
✓ Overturning			7.04
✓ Base Sliding			2.64
Internal			
✓ Pullout	3	6	3.00
✓ Internal Sliding	1	2	5.45
✓ Tensile Overstress	1	2	5.04
Local			
✓ Connection Strength	1	2	3.83



## Get Started by Automatically Generating a Design

### Generate All

Clicking the **Generate All** button will automatically design all sections. It is the recommended method to start designing all panels. This button will overwrite all previously generated sections.

### Generate

The user can select a section or multiple sections (by holding the **CTRL** key or the **Shift** key) to automatically generate a design. Sections are selected from the section list or by clicking on the **Elevation View** image. After the section or sections are chosen, the user can click the **Generate** button to design those sections.

### Force Uniform Grid Length

Check the **Force Uniform Grid Length** box to force the program to use grid lengths of the same length in each panel when generating a design.

### Use No Fines

Check the **Use No Fines** box to analyze the wall using a no-fines concrete mass gravity system. This IS NOT available using the AASHTO or Rankine design methods.

## Modifying an Automatically Generated Design

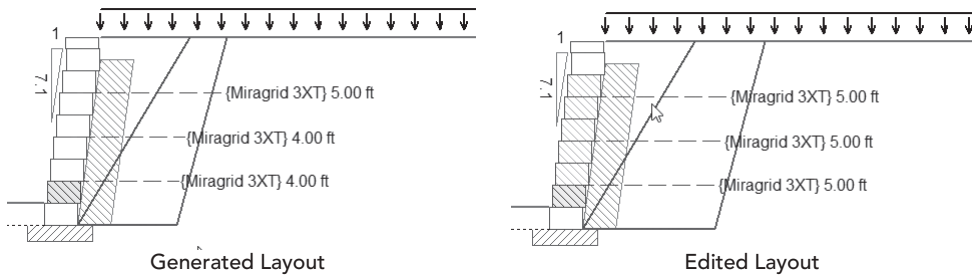

## Reinforcement

The selected reinforcement products chosen on the **Reinforcement** tab are listed. To change the reinforcement layer or layers to a different product or strength, on the **Section View** image, select the unit just below the grid layer or multiple units (by holding the **CTRL** key or the **Shift** key). Select the new reinforcement strength and click the **Edit** button to the right.

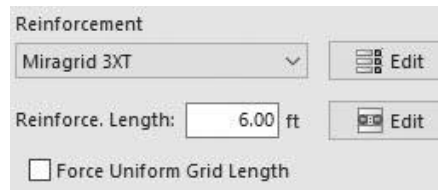

### Reinforcement Length

To change the length of the reinforcement layer or layers, use the graphical method outlined above to select the layer or layers you want to edit. Next, type the new reinforcement length in the text box. Finally, click the **Edit** button to the right.



## Modifying an Automatically Generated Design (continued)

### Design Edit Buttons

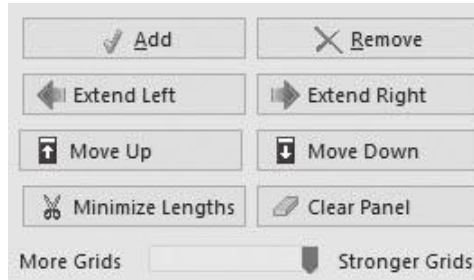

#### Adding and Removing Layers

The **Add** and **Remove** button will add or remove a reinforcement layer just above the unit selected in the **Section View** for a panel selected. (If no unit is selected, KeyWallPRO will add or delete the grid layer above the bottom unit.) A simpler method of adding and removing layers is to double-click the units in the **Section View**. Double-clicking a block will add or remove a layer just above the block.

#### Extend Left and Extend Right

Multiple panels can be redesigned to match the design of a selected panel by pressing the **Extend Left** or **Extend Right** buttons. The panel design, reinforcement length, and elevation will be copied to the end of the wall in the direction chosen (see note on left).

#### Move Up and Move Down

All layers of a panel (or multiple selected panels) can be moved up or down one course by pressing the **Move Up** or **Move Down** button.

#### Minimize Lengths

Press the **Minimize Lengths** button to reduce the geogrid length for the selected panels to the minimum grid length based on the **Min. Reinforcement Length** and **Min. L/H Ratio** defined on the **Design Criteria** tab. This may be desirable when the **Generation Increment** selected on the **Reinforcement** tab is greater than 1 foot.

#### Clear Panel

Press the **Clear Panel** button to remove grid layers for the selected panels.

#### More Grids / Stronger Grids

Use the **More Grids / Stronger Grids** toggle switch to change the generation algorithm to either use closely spaced reinforcement layers of the same strength or to maintain the spacing and increase the strength to the next strongest reinforcement product selected.

#### Grid Group Increment

The user can check the box to apply the **Grid Group Increment** when using the **Generate All** button. KeyWallPRO will automatically generate a design for all panels, adjusting the geogrid length based on the increment chosen and then assign group letters to panels with like reinforcement lengths.

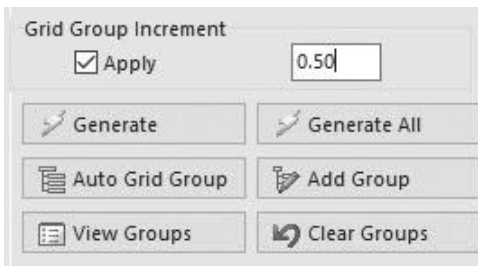

#### Note:

When reinforcement layers are extended left or right, additional layers will need to be manually added where the wall steps up or down.

#### Note:

KeyWallPRO will not use a **Group Grid Increment** that is less than the **Generation Increment** on the **Reinforcement** tab.



**Grid Group Increment** (continued)

**Auto Grid Group**

The user can click the **Auto Grid Group** button to automatically group the previously designed panels with similar geogrid lengths.

**Add Groups**

The user can graphically select multiple panels and click the **Add Group** button to define those panels as a group and save it with a specified name and description. If you have previously pressed the **Auto Grid Group** button, those groups will disappear.

**View Groups**

The user can click the **View Groups** button to open a window that lists a summary of the reinforcement length information for each group.

**Clear Groups**

The **Clear Groups** button will clear all groups.

**Analysis**

Failure Mode	Layer	Course	Value
<b>External</b>			
✓ Bearing Capacity			7.47
✓ Crest Toppling		5	2.37
✓ Overturning			5.75
✓ Base Sliding			2.36
<b>Internal</b>			
✓ Pullout	2	5	1.62
✓ Internal Sliding	1	2	6.06
✓ Tensile Overstress	1	2	5.19
<b>Local</b>			
✓ Connection Strength	1	2	3.74

Panel Wall Area:	237.50 ft <sup>2</sup>
Reinforcement Area:	47.33 yd <sup>2</sup>
Infill Volume:	25.84 yd <sup>3</sup>

<b>Analysis</b>	
<b>Analyze Panel</b> -	After a manual change to the design of a single panel or multiple panels, the user must select the <b>Analyze Panel</b> button to recalculate the results. <i>Note: only the selected panels will be recalculated.</i>
<b>Analyze All</b> -	The user can select the <b>Analyze All</b> button to recalculate the results for all panels.
<b>Quick Results</b> -	A short summary of the calculated results is shown inside the window to the right of the Section View.
<b>Full Output</b> -	The full design output, including all intermediary calculated values, can be viewed by pressing the <b>Full Output</b> button.

**Trial Wedge**

The user can check the **Apply** box to model loading using the trial wedge method. The **Limit** field sets the distance behind the backface that the trial wedge will analyze out to.





**PART FIVE**  
Installation & User's Guide

**Analysis (continued)**

In the output shown below, the base sliding failure mode is selected and the detailed calculations are shown in the right window.

Failure Mode	Layer	Course	Value	Description	Term	Layer	Course	Value	Eq. Ref.
<b>External</b>									
✓ Bearing Capacity			7.47	Weight of soil above wall	W <sub>β</sub> 1			0.00 lb/ft	7-31A1
✓ Crest Toppling		5	2.37	Weight of soil above wall	W <sub>β</sub> 2			0.00 lb/ft	7-31A2
✓ Overturning			5.75	Weight of soil above wall	W <sub>β</sub> 3			0.00 lb/ft	7-31A3
✓ Base Sliding			2.36	Dead load over reinforced zone	W <sub>G</sub> dl			0.00 lb/ft	
<b>Internal</b>									
✓ Pullout	1	2	2.72	Weight of reinforced mass	W <sub>ri</sub>			2390.08 lb...	7-30
✓ Pullout	2	5	1.62	Weight of soil above wall	W <sub>β</sub>			0.00 lb/ft	7-31
✓ Internal Sliding	1	2	6.06	Base sliding resistance	R <sub>s</sub>			1270.83 lb...	7-32
✓ Internal Sliding	2	5	17.45	Base sliding	F <sub>Sl</sub>			2.359	7-33
✓ Tensile Overstress	1	2	5.19	Increase in height due to backslope	hs			0.00 ft	7-7
✓ Tensile Overstress	2	5	11.14	Width of rein. layer for internal sliding	L's			0.00 ft	7-8
<b>Local</b>									
✓ Connection Strength	1	2	3.74	Equivalent slope at back of rein. zone	β <sub>ert</sub>			0.00 °	7-9
✓ Connection Strength	2	5	6.74	Height of back of wall for ext. stability	H <sub>ext</sub>			4.98 ft	7-10
				Horizontal width of rein. zone at backslope	L <sub>B</sub>			3.09 ft	7-11
				Slope for internal analysis	β <sub>int</sub>			0.00 °	7-46
				Elevation of influence of live load	Eq <sub>linf</sub>			4.98 ft	7-93
				Elevation of influence of dead load	Eq <sub>dinf</sub>			4.98 ft	7-94
				External interface friction angle	δ <sub>e</sub>			0.00 °	7-2
				Internal interface friction angle	δ <sub>i</sub>			0.00 °	7-44
				External failure plane	oe			59.00 °	5-5
				Internal failure plane	oi			59.00 °	7-50
				Width of reinforced zone	L'			3.09 ft	7-3

**DESIGN Tab (Wall Section Analysis)**

Project: design manual [Rev. 1] - KeyWallPRO

File Walls Settings Help

Project 1

Design Criteria Wall Unit Reinforcement Soil Conditions Extreme Events Design Internal Compound Stability

Include Cap in Height (all sections)

0=50

Design Height 10.00 ft [Add]

Embedment 1.00 ft [Delete]

Exposed Height 9.00 ft

Facing Height 10.33 ft

Slope and Surcharges

Slope 0.00 \* Offset 0.00 ft

Live Load 0.00 lb/ft² Offset 0.00 ft

Dead Load 0.00 lb/ft² Offset 0.00 ft

Use No Fines

Reinforcement

Miragrid 3XT [Edit]

Length: 0.00 ft [Edit]

Force Uniform Grid Length

[Add] [Remove]

[Minimize] [Clear Panel]

[Generate] [All] [Full Output]

[Analyze] [All]

Section 0=50 Static Seismic

Failure Mode	Layer	Course	Value
<b>External</b>			
✓ Bearing Capacity			8.16
✓ Crest Toppling		13	9.14
✓ Overturning			9.08
✓ Base Sliding			3.46
<b>Internal</b>			
✓ Pullout	5	13	1.92
✓ Internal Sliding	1	1	3.56
✓ Tensile Overstress	1	1	4.14
<b>Local</b>			
✓ Connection Stre...	2	4	3.83
✓ Minimum Embe...			11.1100 %
✓ Min. Reinforce...			8.0000 ft
✓ Min. L/H Ratio			0.8000
✓ Min. Anchorage...			1.3894 ft
✓ Minimum Embe...			12.0000 in...
✓ Max. Reinforce...			2.0000 ft
✓ Max. multiple of...			1.0000
✓ Max. multiple of...			2.0000

Version: 1.40.12.1050 National Concrete Masonry Association 3rd Edition Keystone Retaining Wall Systems LLC



**DESIGN Tab (Wall Section Analysis) (continued)**

**Get Started by Adding a Section and Defining It**

**Add**

The user can start adding design sections to the wall by clicking the **Add** button. A window will open that allows the user to define a name for the section. The new section will appear in the list box located in the upper left hand corner. After a section has been created, it can be further defined and analyzed.

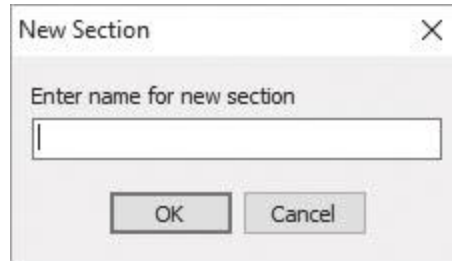

**Section List**

The list box displays all sections created. The user can select sections to analyze. The arrows on the right will re-order the selected case.

**Delete**

The user can delete a selected case in the list by clicking the **Delete** button.

**Include Cap in Height**

Check **Include Cap in Height (all sections)** to set the top of the cap at or above the top of ground line.

**Design Height**

The total design height, including the embedded portion up to the finished grade line at the top of the wall.

**Embedment**

The distance between the finished grade at the base of the wall and the top of the leveling pad.

**Exposed Height**

The distance above grade. This is automatically calculated.

**Facing Height**

The total design height of the wall facing, including Keystone units and cap.

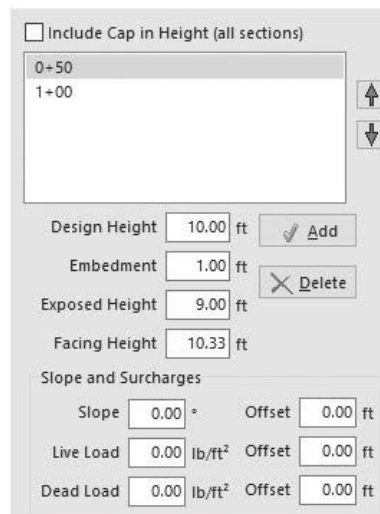

Slopes and Surcharges			
<b>Slope</b> -	The slope angle above the wall	<b>Slope Offset</b> -	The length of the slope behind the upper unit
<b>Live Load</b> -	A transient surcharge	<b>Live Load Offset</b> -	The distance to the live load behind the upper unit
<b>Dead Load</b> -	A permanent surcharge	<b>Dead Load Offset</b> -	The distance to the dead load behind the upper unit



## PART FIVE

### Installation & User's Guide

#### Get Started by Adding a Section and Defining It (continued)

##### Use No Fines

Check the **Use No Fines** box to analyze the wall using a no-fines concrete mass gravity system. This IS NOT available using the AASHTO or Rankine design methods.

##### Force Uniform Grid Length

Check the **Force Uniform Grid Length** box to force the program to use grid lengths of the same length when generating a design.

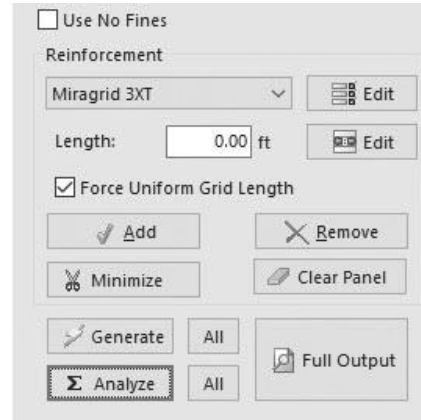

#### Generate a Design for the Sections

##### Generate

After the wall height, backslope and surcharge information has been entered, the user can click the **Generate** button and KeyWallPRO will generate a design for the selected case using the reinforcement products previously chosen on the **Reinforcement** tab.

##### All

The user can click the **All** button located to the right of the **Generate** button to generate a design for all cases.

#### Modifying a Design Section

Section View Image Single Grid Edit

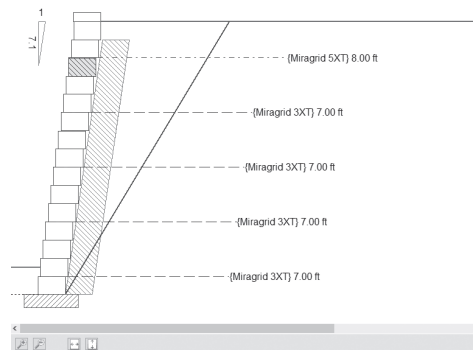

Section View Image Multi Grid

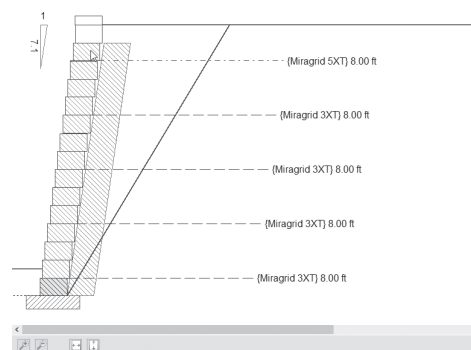



Modifying a Design Section (continued)

<p><b>Reinforcement</b></p> <p><b>Changing Reinforcement Strength</b> The selected reinforcement products chosen on the <b>Reinforcement</b> tab are listed. To change the reinforcement layer or layers to a different product or strength, on the section image select the unit just below the grid layer or multiple units (by holding the <b>CTRL</b> key or the <b>Shift</b> key). Select the new reinforcement product from the dropdown list and click the <b>Edit</b> button to the right.</p> <p><b>Length</b> To change the length of the reinforcement layer or layers, use the graphical method outlined above to select the layer or layers you want to edit. Next, type the new reinforcement length in the text box. Finally, click the <b>Edit</b> button to the right.</p> <p><b>Adding and Removing Layers</b> The <b>Add</b> and <b>Remove</b> buttons will add or remove a reinforcement layer just above the unit selected in the section image for the case selected. (If no unit is selected, KeyWallPRO will add or delete the grid layer above the bottom unit.) A simpler method of adding and removing layers is to double-click the units in the section image. Double-clicking a block will add or remove the layer just above the block.</p> <p><b>Minimize</b> Press the <b>Minimize</b> button to reduce the geogrid length for the selected case to the minimum grid length based on the <b>Min. Reinforcement Length</b> and <b>Min. L/H Ratio</b> defined on the <b>Design Criteria</b> tab. This may be desirable when the <b>Generation Increment</b> selected on the <b>Reinforcement</b> tab is greater than 1 foot.</p> <p><b>Clear Panel</b> Press the <b>Clear Panel</b> button to remove grid layers for the selected section.</p>
---

**Analyze**

The user can select the **Analyze** button to recalculate the results for the selected case. This would be required after making ANY manual changes to the design.

**All**

The user can click the **All** button located to the right of the **Analyze** button to recalculate the results for all cases.

**Quick Results**

A short summary of the calculated results is shown inside the window to the right of the section image.

**Full Output**

The full design output, including all intermediary calculated values for the selected case, can viewed by pressing the **Full Output** button.

Section 0+50			
	<input checked="" type="radio"/> Static		<input type="radio"/> Seismic
Failure Mode	Layer	Course	Value
<b>External</b>			
✓ Bearing Capacity			8.16
✓ Crest Toppling		13	9.14
✓ Overturning			9.08
✓ Base Sliding			3.46
<b>Internal</b>			
✓ Pullout	5	13	1.92
✓ Internal Sliding	1	1	3.56
✓ Tensile Overstress	1	1	4.14
<b>Local</b>			
✓ Connection Stre...	2	4	3.83
✓ Minimum Embe...			11.1100 %
✓ Min. Reinforce...			8.0000 ft
✓ Min. L/H Ratio			0.8000
✓ Min. Anchorage...			1.3894 ft
✓ Minimum Embe...			12.0000 in...
✓ Max. Reinforce...			2.0000 ft
✓ Max. multiple of...			1.0000
✓ Max. multiple of...			2.0000



## PART FIVE

### Installation & User's Guide

#### INTERNAL COMPOUND STABILITY Tab

The user can check Internal Compound Stability for each panel or design section (done separately). The KeyWallPRO program uses the NCMA 3rd Edition method for calculating ICS for all design methods. ICS checks the moment equilibrium of circular failure surfaces entering behind the reinforced soil zone a specified distance. The analysis divides the circular failure sections into slices and analyzes them based on the Simplified Bishops Procedure. Additional resisting moments from the reinforcement and facing are added when calculating the factor of safety.

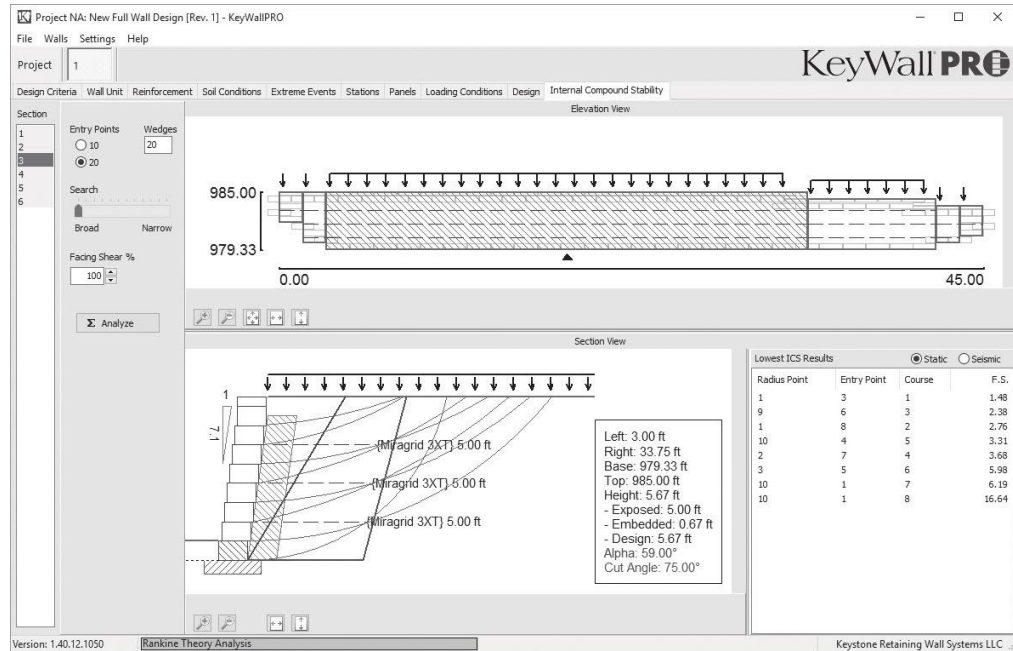

#### Full Wall Design

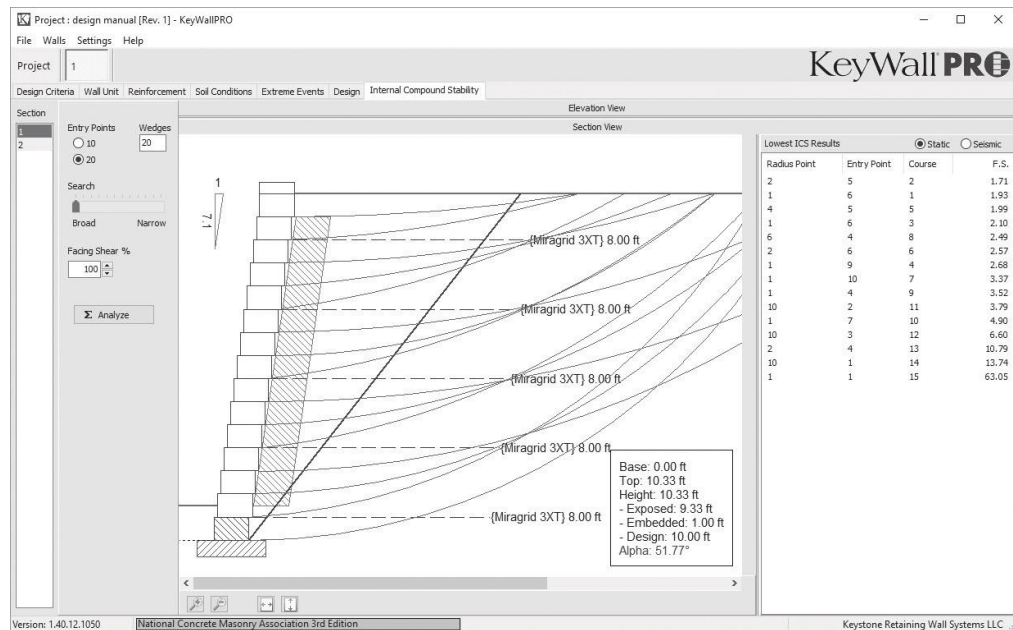

#### Wall Section Analysis



## Printing Results

First, choose the **PDF Report...** selection on the **File** tab menu.

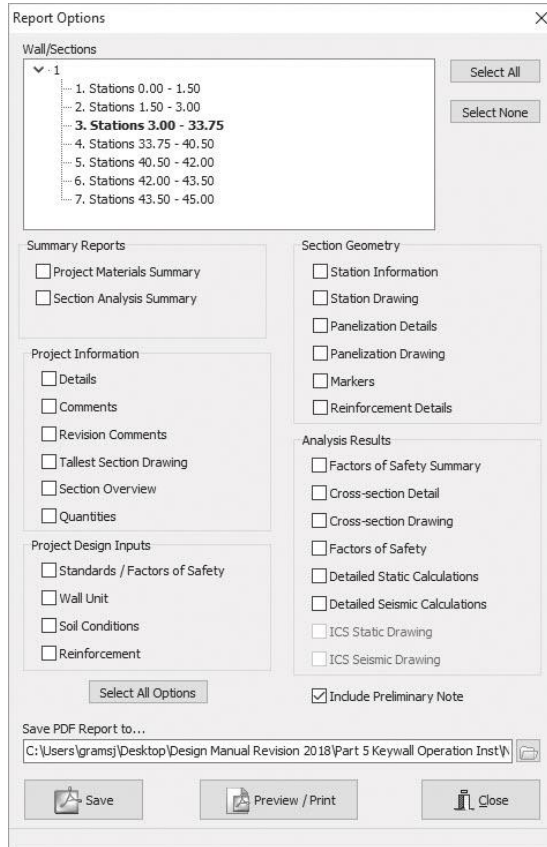
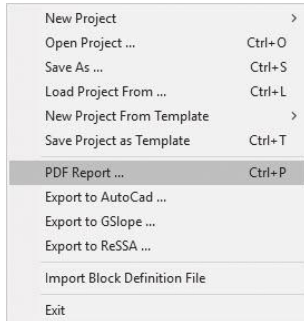

**Note:**  
*PDF report will be saved in this specified location on your computer.*

## Selecting Wall/Sections to Print

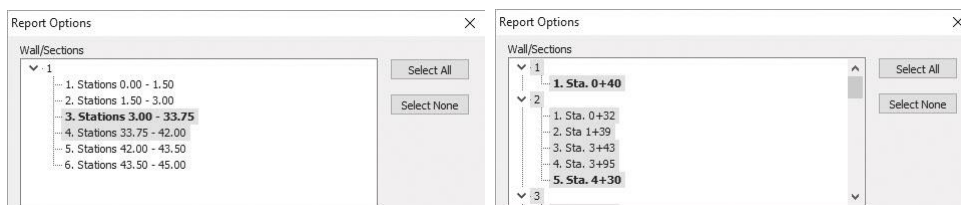

## Selecting Individual Cases

Select the design cases from the **Wall/Sections** tree view window that you would like to print. Hold down the **CTRL** button and select each case separately or use the **Shift** key. This will highlight each case selected to print.

### Select All

Click the **Select All** button to print results for all cases.

### Select None

Click the **Select None** button to clear all cases selected to print.



## PART FIVE

### Installation & User's Guide

**Note:**

*Quantity information is valid for a Full Wall Design only.*

#### Printing Results (continued)

##### Reports Available to Print for Each Section

###### Summary Reports

###### Project Materials Summary

A summary of wall area, cap area, geogrid quantity, drainage rock quantity and reinforced backfill quantity will be printed for all walls.

###### Section Analysis Summary

This will print a short form of the results for each case.

###### Project Information

###### Details

Client, Project Name/Number, Site/Designer, Revision/Created/Modified, Design Method, Seismic As

###### Comments

Prints the Project Notes from **Project** tab.

###### Revision Comments

Prints the Revision Notes from **Project** tab.

###### Tallest Section

Prints a diagram of the tallest section.

###### Quantities

Displays a summarized listed view of quantities for the walls selected.

###### Project Design Inputs

###### Standards/Factors of Safety

Prints all factors of safety and load and resistance factors (for AASHTO LRFD methods) used in the design.

###### Wall Unit

Prints the **Wall Unit** dimensions, weight, setback and shear information.

###### Soil Conditions

Prints the soil parameters used in the design.

###### Reinforcement

Prints the soil reinforcements used, including strength properties and connection data.

###### Section Geometry

###### Station Information

Prints the panel stationing limits, elevations and heights for the walls selected.

###### Station Drawing

Prints an elevation view of the top and bottom grade lines for the walls selected.

###### Panelization Details

Prints a summary of the panel stationing, geometry, quantities and loading information for the walls selected.

###### Panelization Drawing

Prints an elevation drawing that includes panels, wall units, grade lines and reinforcement layers for the walls selected.

###### Markers

Prints markers if specified. These could include corners, PC, PT, utilities, etc.

###### Reinforcement Details

Prints a table that represents the reinforcement layout for each panel that includes the course where the layers reside, length, area and type.

**Note:**

*The Project Materials Summary and Section Analysis Summary are the most common selections for printing short results.*



Printing Results (continued)

<p><b>Analysis Results</b></p> <p><b>Factors of Safety Summary</b> Prints the required factors of safety and the ALL calculated factors of safety for the external stability and internal stability results, among other design checks.</p> <p><b>Cross Section Details</b> Appends the geometry and surcharge information associated with the cross section for the cases selected to the <b>Analysis Summary</b> printout.</p> <p><b>Cross Section Drawing</b> Appends a drawing of the cross section for the cases selected to the <b>Analysis Summary</b> printout.</p> <p><b>Factors of Safety</b> Appends the required factors of safety and the CRITICAL calculated factors of safety for the external stability and internal stability results, among other design checks, to the <b>Analysis Summary</b> printout.</p> <p><b>Detailed Static Calculations</b> Appends the complete static results including all intermediate calculation results for external stability and internal stability to the <b>Analysis Summary</b> printout.</p> <p><b>Detailed Seismic Calculations</b> Appends the complete seismic results including all intermediate calculation results for external stability and internal stability to the <b>Analysis Summary</b> printout.</p> <p><b>ICS Static Drawing</b> Appends an image of the static ICS cross-section to the <b>Analysis Summary</b> printout.</p> <p><b>ICS Seismic Drawing</b> Appends an image of the seismic ICS cross-section to the <b>Analysis Summary</b> printout.</p>
---

**Note:**  
*Capacity demand ratios (CDR) are listed for AASHTO LRFD design methods versus factors of safety.*

**Note:**  
*Select Cross Section Details, Cross Section Drawing, Detailed Static Calculations and Detailed Seismic Calculations (if applicable) for long results.*

**Include Preliminary Note**

When the **Include Preliminary Note** box is checked, the printout includes the following:  
NOTE: These calculations, quantities, and layouts are for preliminary design only and should not be used for construction without review by a qualified engineer.

**Select All Options**

The user can click the **Select All Options** button to automatically select all the printout options.

**Save PDF Report to...**

The user should click the folder to specify the save file location for the PDF results.

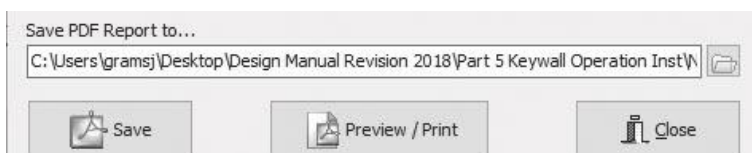

**Save**

Click the **Save** button to automatically save the PDF printout to the specified location.

**Preview / Print**

Click the **Preview / Print** button to view the pdf results. This opens a temporary PDF that will not be saved unless saved within the PDF software used to view the file.

**Close**

Click the **Close** button to close the print dialog window (**Report Options**).





## Export to AutoCad

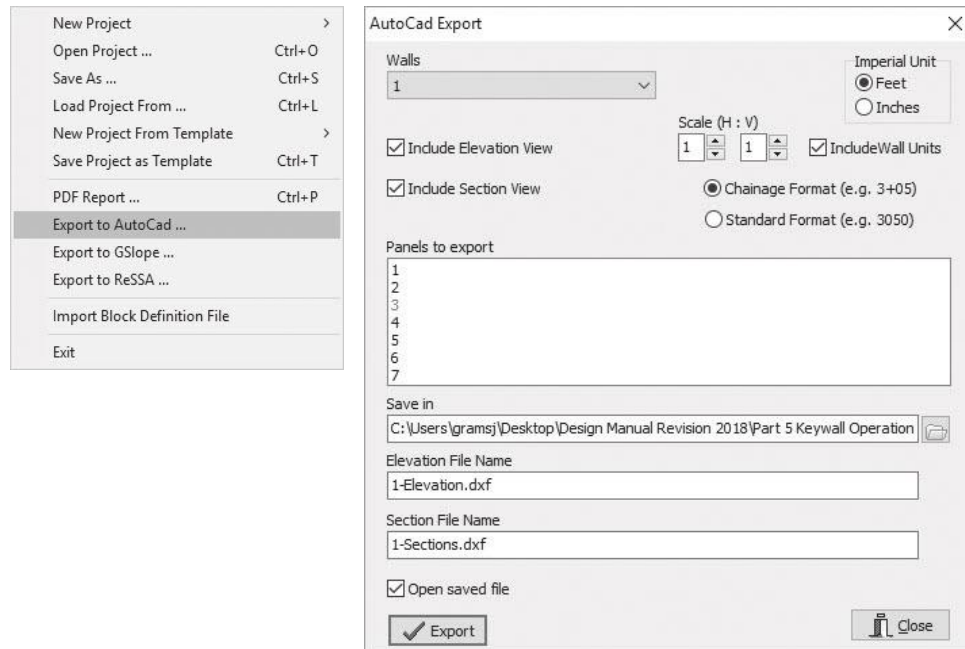

### AutoCad Export Steps

- 1 Select the wall to export using the dropdown list.
- 2 Check **Include Elevation View** and/or **Include Section View** to export the wall elevation and section(s) respectively.
- 3 Choose the **Imperial Unit**, feet or inches, using the radio button.
- 4 Specify the Scale (H : V) if an expanded scale is desired.
- 5 Check **IncludeWall Units** to include a drawing of the units and caps in the **Elevation View** dxf.
- 6 Specify the **Chainage Format** (e.g. 3+05) or **Standard Format** (e.g. 3050) for the stationing used.
- 7 From the list, select the panel or panels (by holding the **CTRL** key or using the **Shift** key) to export sections.
- 8 Specify the **Save In** folder where the dxf files will be saved. The project file folder is the default path.
- 9 Specify the **File Name** of the **Elevation File** and **Section File**. Multiple sections will be saved in the **Section File**.
- 10 Check **Open saved file** box to automatically open the exported dxf files.
- 11 Lastly, click the **Export** button to export the dxf files to the specified folder.
- 12 Repeat this procedure for multiple walls.



## Importing or Updating Data Files

KeyWallPRO comes preloaded with the current data set for the Keystone Pinned and Lip-Lug units. The base data sets include Keystone units and geogrid reinforcement properties that can change periodically due to inclusion of new products or manufacturer changes to products. Also, additional data file sets are available at [www.keystonewalls/softwareresources](http://www.keystonewalls/softwareresources) for international markets, special product lines, or special design circumstances such as DOT-approved design parameters. Users may find it necessary to import or update data files.

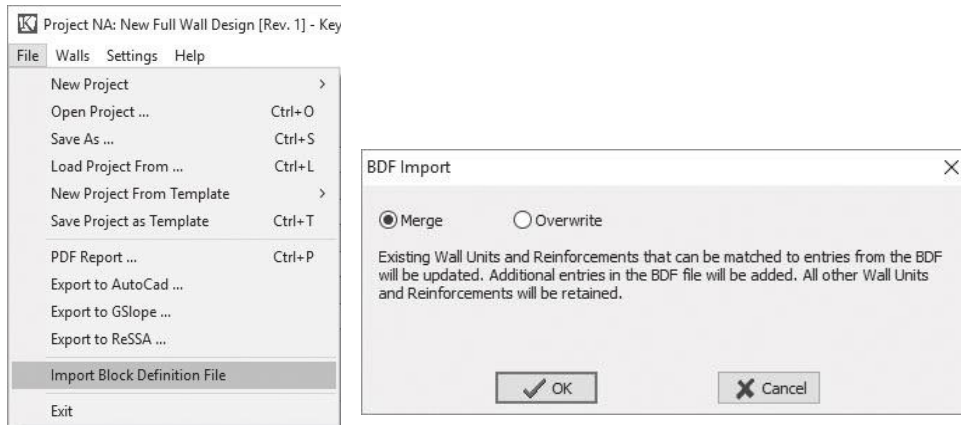

### Steps to Import Data Files (.BDF)

- 1 Select **Import Block Definition File** from the File dropdown menu.
- 2 Locate and select the appropriate .BDF file for import and click the **Open** button.
- 3 A dialog box will appear with the **Merge** or **Overwrite** options. Select the desired option and press the **OK** button.

#### Merge

**Merge** will take the new data file and merge that data with the existing data. This option maintains the database and only updates the unit and geogrid information contained in the new file.

#### Overwrite

**Overwrite** will delete all existing data files and install the new data file. This option is for starting over and clearing the database. Using **Overwrite** for one file and then **Merge** for additional files will reconstruct the database with the desired contents.

- 4 A confirmation box will appear when the import is complete.

# PART SIX



## APPENDIX A

*Parq at Iliff Apartments, Aurora, Colorado; Keystone Compac® - Victorian Ashlar*





## INFINITE SLOPE SURCHARGE NCMA 3RD EDITION - COULOMB METHODOLOGY

This set of calculations is intended to verify the KeyWallPRO program output of a typical gravity wall design section. The design follows the procedure outlined in the 2010 NCMA Design Manual for Segmental Retaining Walls. The pertinent design information is summarized below:

### 1) General Design Data

Keystone Compac III Units (120 pcf with unit drainage fill and  $W_u = 1.0'$ )  
 Crushed Stone Leveling Pad ( $\phi = 40^\circ$ )  
 Wall Batter ( $t$ ) = 8 degrees (1" - 1.25" per 8" unit)  
 Design Height = 3.0' (2.5' exposed + 0.5' embedment)  
 Backslope, ( $\beta$ ) = 1V:4H (14.0 degrees)  
 Length of Backslope = 50' (infinite for design purposes)  
 Surcharge = 0 psf (not applied to infinite slope design)  
 Gravity wall design ( $FS_{ot} > 1.5$ )

### 2) Soil Parameters (degrees, psf, pcf)

SOIL PARAMETERS	$\phi$	c	$\gamma$
Retained Soil	30	0	120
Foundation Soil	30	0	120

### 3) Geometric Parameters

$\phi$  = 30 degrees  
 $\delta$  =  $\frac{2}{3}\phi = 20$  degrees (concrete to soil)  
 $\alpha$  = 98 degrees ( $90^\circ + 8^\circ$ )  
 $\beta$  = 14 degrees (4H:1V slope)

### 4) Coulomb Earth Pressure Calculation

Equation (3c)

$$k_a = \frac{\sin^2(98 + 30)}{\sin^2 98 \sin(98 - 20) \left[ 1 + \sqrt{\frac{\sin(30 + 20) \sin(30 - 14)}{\sin(98 - 20) \sin(98 + 14)}} \right]^2}$$



## INFINITE SLOPE SURCHARGE NCMA 3RD EDITION - COULOMB METHODOLOGY

Equation (3c)  $k_a = 0.295$  for above parameters - Coulomb

Equation (3a)  $P_a = \frac{1}{2} \gamma H^2 k_a$

$$P_{ah} = \frac{1}{2} \gamma H^2 k_a \cos(\delta - \alpha)$$

$$P_{ah} = (0.5) (120 \text{pcf}) (3')^2 (0.295) \cos(20 - 8)$$

$$P_{ah} = 156 \text{ lbs/lf}$$

### External Stability Diagram

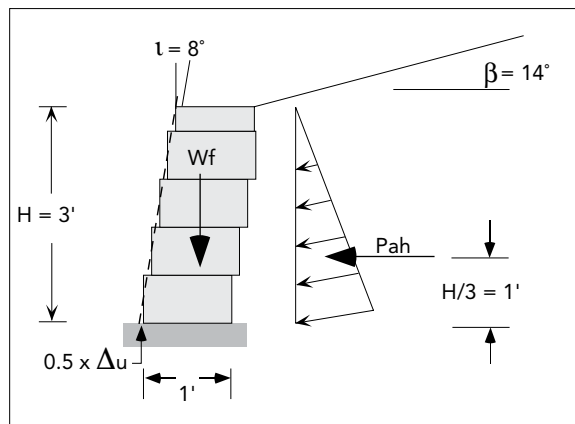

### 5) Overturning

#### Overturning Moment

$$\begin{aligned} M_o &= P_{ah} (H/3) + P_{qh} (H/2) \\ &= 156 \text{ lbs} (3'/3) + 0 \\ &= 156 \text{ ft-lbs} \end{aligned}$$

#### Resisting Moment

$$M_r = W_f \times X = (H W_u \gamma) (W_u / 2 + (H/2) \tan(\alpha) - 0.5 \times \Delta u)$$

where:

$$\begin{aligned} \Delta u &= 1.125' = 0.09' \\ &= (3' \times 1' \times 120 \text{pcf}) (1'/2 + (3'/2) \tan(8) - 0.5 \times 0.09') \\ &= 239 \text{ ft-lbs} \end{aligned}$$

$$FS_{ot} = M_r / M_o = 239/156 = 1.53 > 1.5 \text{ OK}$$



## INFINITE SLOPE SURCHARGE NCMA 3RD EDITION - COULOMB METHODOLOGY

### 6) Sliding

#### Sliding Resistance

$$\begin{aligned} F_v &= 0.92 R_v \tan 40^\circ = 0.92 (3' \times 1' \times 120\text{pcf}) (\tan 40) = 278 \text{ lbs/ft} \\ &= 278 \text{ lbs/lf} \\ FS_{sl} &= F_v / P_{ah} = 278 / 156 = 1.78 > 1.5 \text{ OK} \end{aligned}$$

### 7) Bearing Pressure *(under crushed stone leveling pad)*

$$\begin{aligned} \text{Equation (3i)} \quad e &= B/2 - (M_r - M_o) / R_v \\ &= 1' / 2 - (239 - 156) / (3' \times 1' \times 120\text{pcf}) \\ &= 0.269' \end{aligned}$$

#### Applied Bearing Pressure *(under 6" pad)*

$$\begin{aligned} \text{Equation (3j)} \quad \sigma_v &= R_v / ((B - 2e) + 0.5') \\ \text{(modified)} &= (3 \times 120\text{pcf}) / ((1' - 2 \times 0.269') + 0.5) \\ &= 374 \text{ lbs/sf} \end{aligned}$$

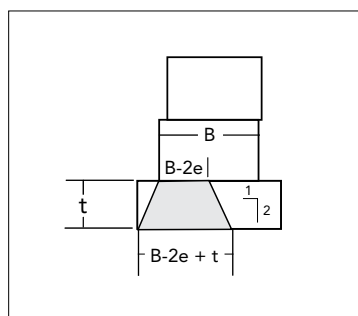

### 8) Bearing Capacity *(under crushed stone leveling pad)*

$$\text{Equation (3k)} \quad Q_{ult} = cN_c + \gamma DN_q + 0.5\gamma(B-2e)N_\gamma$$

where:

$$\begin{aligned} N_c &= 30.14, N_q = 18.4, N_\gamma = 22.40 \\ B &= (B - 2e) + 0.5 = (1' - 2 \times 0.269) + .5 = 0.96' \\ D &= 0.5 \\ c &= 0 \\ Q_{ult} &= 0 + (120) (0.5) (18.4) + (0.5) (120) (0.96) (22.40) \\ &= 2394 \text{ psf} \\ FS_{br} &= 2394/374 = 6.40 > 2.0 \text{ OK} \end{aligned}$$

#### Note:

*Factor of safety in bearing without 6" crushed stone base (below block) is only 2.21.*



## **INFINITE SLOPE SURCHARGE NCMA 3RD EDITION - COULOMB METHODOLOGY**

### 9) Inter-Unit Shear

The inter-unit shear of Keystone Compac III units is over 1,300 lbs/lf plus overburden pressure friction. The maximum driving force is 156 lbs/lf, so by inspection, inter-unit shear is more than adequate with the Keystone Compac III units.

### 10) General Comments

Gravity wall design is very sensitive to wall batter, backslope, surcharge, assumed soil properties, and foundation stability. Small variations can result in unacceptable safety factors and potential wall movement. Inadequate surface drainage can permit saturation of the retained soils and foundation soils, which can also cause wall instability and movement.



## INFINITE SLOPE SURCHARGE NCMA 3RD EDITION - COULOMB METHODOLOGY

Project: Keystone Design Manual - Appendix A [Rev. 1] NA
Wall: Gravity Wall, Infinite Slope, NCMA 3rd Edition

---

**Section** Gravity Wall, Infinite Slope, NCMA 3rd Edition

**Report Date** October 24, 2019

**Designer** JLG

**Design Standard** National Concrete Masonry Association 3rd Edition

**Design** Static

**Unit of Measure** U.S./Imperial

**Selected Facing Unit** Product Line: Keystone Pinned Systems  
Name: Compac III

**Seismic As** N/A

---

Soil Parameters	Phi Angle [degrees]	Cohesion [lb/ft²]	Unit Weight [lb/ft³]	Friction Factor	Description
Retained	30	0.00	120.00	n/a	
Foundation	30	0.00	120.00	n/a	
Leveling Pad	40	n/a	n/a	0.92	
Drainage	38	n/a	115	n/a	

**Section Details**

Section Height	3.00	Back Slope	14.00°	LL Surcharge	0	DL Surcharge	0
Design Height	3.00 ft	Crest Offset	0.00 ft	LL Offset	0.00 ft	DL Offset	0.00 ft
Embedment	0.50 ft	Wall Batter	8.00°	Toe Slope	0.00°	Toe Offset	0.00 ft

**Minimum Factors of Safety**

Conventional		Value	Internal	Value	Facing	Value
FSSl	Base Sliding	1.50	FSSl	Internal Sliding	1.50	
FSbc	Bearing Capacity	2.00	FSSc	Shear Capacity	1.50	
FSot	Overturning	1.50				

**Analysis Results**

- \* Analysis does not include Vertical Forces
- \* Uses External Horiz. Accel Coeff in Seismic Crest Toppling
- \* Embedment is included in Bearing Capacity

External Static		FS	
Bearing Capacity	6.42	Bearing Pressure	373.60 lb/ft²
Overturning	1.54	Max Eccentricity	0.27 ft
Base Sliding	1.79		

Internal Static		Shear Capacity	
Course	Elevation [ft]	FS	
1	0.67	10.51	
2	1.33	16.81	
3	2.00	31.82	

NOTE: THESE CALCULATIONS, QUANTITIES, AND LAYOUTS ARE FOR PRELIMINARY DESIGN ONLY  
AND SHOULD NOT BE USED FOR CONSTRUCTION WITHOUT REVIEW BY A QUALIFIED ENGINEER

---

Powered by KeyWallPRO

Page 2

Printed 10/24/2019  
Version: 1.40.12.1050



# PART SIX



## APPENDIX B

*TCU Parking Garage, Fort Worth, Texas; Regal Stone Pro® RockFace 3-pc*





## NCMA 3RD EDITION - COULOMB METHODOLOGY LEVEL SURCHARGE - 250 PSF

This set of calculations is intended to verify the KeyWallPRO program output of a typical reinforced soil wall design section. The design follows the procedure outlined in the 2010 NCMA Design Manual for Segmental Retaining Walls.

The pertinent design information is summarized below:

### 1) General Design Data

Regal Stone Pro Units (120 pcf with drainage fill and  $W_u = 1.00'$ )

Stratagrid SG200 Polyester Geogrid

Wall Batter ( $t$ ) =  $7.1^\circ$

Design Height =  $10'$  ( $9'$  exposed +  $1'$  embedment)

Base Length,  $B$  =  $8.0'$  (uniform lengths chosen for simplicity)

Backslope,  $\beta$  =  $0$ , level backslope

Surcharge =  $250$  psf (typical roadway surcharge)

### 2) Soil Parameters (*Degrees, psf, pcf*)

SOIL PARAMETERS	$\phi$	c	$\gamma$
Reinforced Soil	34	0	120
Retained Soil	30	0	120
Foundation Soil	30	0	120

### 3) Geogrid Design Parameters (*plf*)

Geogrid	$T_{ult}$	$RF_{cr}$	$RF_d$	$RF_{id}$	LTDS	FS	$T_{al}$
Strata SG200	3600	1.55	1.10	1.10	1919	1.5	<b>1280plf</b>

( $C_i$  &  $C_{ds} = 0.90$  for select backfill)

### 4) Geometric Parameters - Coulomb

#### Internal

- $\phi$  = 34 degrees
- $\delta$  =  $\frac{2}{3}\phi = 22.67$  degrees (concrete/soil)
- $\alpha$  = 97.1 degrees ( $90^\circ + 7.1^\circ$ )
- $\beta$  = 0 degrees (level)

#### External

- $\phi$  = 30 degrees
- $\delta$  =  $\phi = 30$  degrees (soil to soil)
- $\alpha$  = 97.1 degrees ( $90^\circ + 7.1^\circ$ )
- $\beta$  = 0 degrees (level)



## NCMA 3RD EDITION - COULOMB METHODOLOGY LEVEL SURCHARGE - 250 PSF

### 5) Coulomb Earth Pressure Calculation

Internal

$$K_a = \frac{\sin^2 (97.1 + 34)}{\sin^2 97.1 \sin (97.1 - 22.67) \left[ 1 + \sqrt{\frac{\sin(34 + 22.67) \sin(34 - 0)}{\sin(97.1 - 22.67) \sin(97.1 + 0)}} \right]^2}$$

Equation (3c)  $k_a = 0.207$  for above parameters - Coulomb

Equation (3d)  $\rho = 55.7^\circ$  for above parameters - Coulomb

External

$$K_a = \frac{\sin^2 (97.1 + 30)}{\sin^2 97.1 \sin (97.1 - 30) \left[ 1 + \sqrt{\frac{\sin(30 + 30) \sin(30 - 0)}{\sin(97.1 - 30) \sin(97.1 + 0)}} \right]^2}$$

Equation (3c)  $k_a = 0.246$  for above parameters - Coulomb

External Forces

Equation (3a)

$$P_a = \frac{1}{2} \gamma H^2 k_a$$

$$P_{ah} = \frac{1}{2} \gamma H^2 k_a \cos(\delta - \iota) \text{ (Horz.)}$$

$$P_{ah} = (0.5) (120 \text{ pcf}) (10')^2 (0.246) \cos(30 - 7.1)$$

$$P_{ah} = 1360 \text{ lbs/lf}$$

External Masses

$$W_f = W_u H \gamma = (1.00')(10')(120 \text{ pcf}) = 1200 \text{ lbs/lf}$$

$$W_i = (B - W_u) H \gamma = (8.0' - 1.75')(10')(120 \text{ pcf}) = 8400 \text{ lbs/lf}$$

$$W_q = q(B - W_u) = (250 \text{ psf})(8.0' - 1.00') = 1750 \text{ lbs/lf}$$

Equation (3b)

$$P_q = qH k_a$$

$$P_{qh} = qH k_a \cos(\delta - \iota) \text{ (Horizontal Component)}$$

$$P_{qh} = (250 \text{ psf})(10')(0.246) \cos(30 - 7.1)$$

$$P_{qh} = 567 \text{ lbs/lf}$$

External Stability Diagram

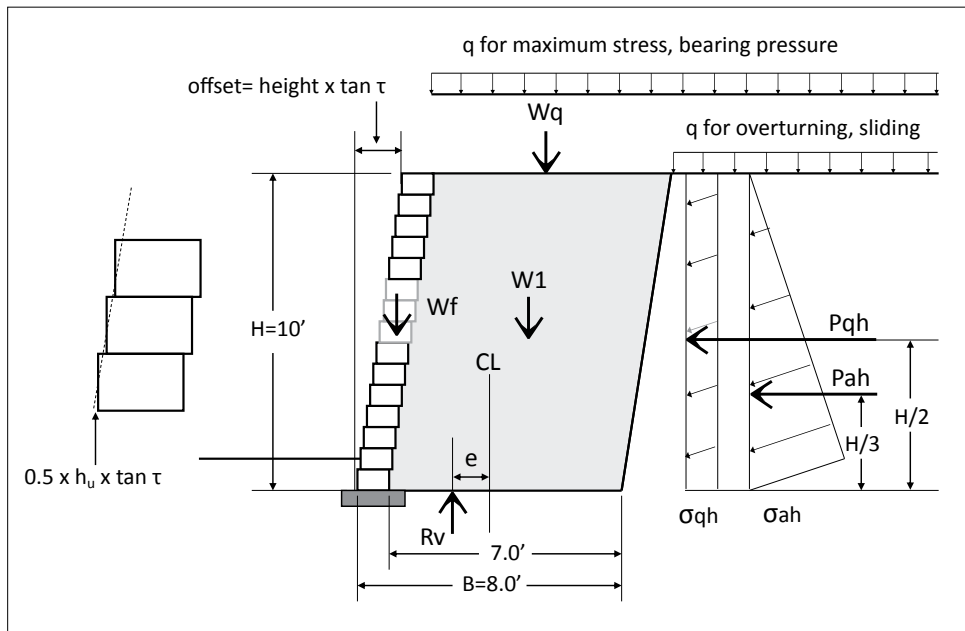



**NCMA 3RD EDITION -  
COULOMB METHODOLOGY LEVEL SURCHARGE - 250 PSF**

6) Overturning

**Overturning Moment**

$$\begin{aligned} M_o &= P_{ah} (H/3) + P_{qh} (H/2) \\ &= 1360 \text{ lbs} (10'/3) + 567 \text{ lbs} (10'/2) \\ &= \mathbf{7368 \text{ ft-lbs}} \end{aligned}$$

**Resisting Moment**

$$\begin{aligned} M_r &= W_f \times \text{arm} + W_1 \times \text{arm} \\ &= (1200 \times 1.08') + 8400 \times 5.08' \\ &= \mathbf{43968 \text{ ft-lbs}} \\ FS_{ot} &= M_r / M_o = 43968 / 7368 = \mathbf{5.97 > 1.5 \text{ OK}} \end{aligned}$$

**W<sub>f</sub> Moment Arm**

$$\begin{aligned} \text{arm} &= (W_u + \text{setback} / 2) - 0.5 h_u \tan \alpha \\ &= (1.0' + 1.25' / 2) - 0.5 (0.67') \tan 7.1^\circ \\ &= \mathbf{1.08'} \end{aligned}$$

**W<sub>1</sub> Moment Arm**

$$\begin{aligned} \text{arm} &= W_u + (L + \text{setback} / 2) - 0.5 h_u \tan \alpha \\ &= 1.0' + (7.0' + 1.25' / 2) - 0.5 (0.67') \tan 7.1^\circ \\ \text{arm} &= \mathbf{5.08'} \end{aligned}$$

7) Base Sliding

**Lateral Driving Forces**

$$\begin{aligned} R_d &= P_{ah} + P_{qh} \\ &= 1360 \text{ lbs} + 567 \text{ lbs} \\ &= \mathbf{1927 \text{ lbs/ft}} \end{aligned}$$

**Lateral Resisting Forces**

$$\begin{aligned} R_r &= (W_f + W_1) \times \tan \phi \text{ of foundation} \\ &= (1200 + 8400) \times \tan 30^\circ \\ &= 5543 \text{ lbs/ft} \\ FS_{sl} &= R_r / R_d = 5543 / 1927 = \mathbf{2.88 > 1.5 \text{ OK}} \end{aligned}$$

8) Sliding at Lowest Reinforcement Level

**Lateral Driving Forces (at depth of 9.33')**

$$\begin{aligned} R_d &= P_{ah} + P_{qh} \\ &= 1184 \text{ lbs} + 529 \text{ lbs} \\ &= \mathbf{1713 \text{ lbs/ft}} \end{aligned}$$

**Lateral Resisting Forces (at depth of 9.33')**

*Block/Grid Shear*

$$\begin{aligned} \tau_{unit} &= a_u + N \tan \lambda_u < V_u (\text{max}) = 3973 \text{ lbs/ft} \\ &= 1260 + N \tan 37^\circ \\ &= 1260 \text{ plf} + (9.33' \times 1.00' \times 120 \text{ pcf}) \tan 37^\circ \\ &= \mathbf{2104 \text{ plf}} \end{aligned}$$

$$\begin{aligned} \tau_{soil} &= (\gamma H (B - W_u) \times \tan \phi \text{ (of reinforced material)}) \times C_{ds} \\ &= 120 \text{ pcf} \times 9.33' \times 7.00' \times \tan 34^\circ \times 0.90 \\ &= \mathbf{4758 \text{ lbs/ft}} \end{aligned}$$

$$FS_{sl} = R_r / R_d = (2104 + 4758) / 1713 = \mathbf{4.00 > 1.5 \text{ OK}}$$



## NCMA 3RD EDITION - COULOMB METHODOLOGY LEVEL SURCHARGE - 250 PSF

### 9) Bearing Pressure (*Note: Live load is added for applied Bearing Pressure*)

#### Eccentricity

##### Equation (3i)

$$\begin{aligned}e &= B/2 - (M_r - M_o)/R_v \\M_r &= 43968 \\&= 48600 + 1813 \times (1.75' + 7.25'/2) = 58345 \text{ ft-lbs} \\R_v &= W_f + W_1 \\&= (1200 + 8400) = 9600 \text{ lbs/ft} \\e &= 8.0'/2 - (43968 - 7368)/(9600) \\&= 0.19'\end{aligned}$$

#### Applied Bearing Pressure

##### Equation (3j)

$$\begin{aligned}R_v &= W_f + W_1 + W_q \\&= (1200 + 8400 + 1750) = 11350 \text{ lbs/ft} \\ \sigma_v &= R_v / (B - 2e) \\&= (11350) / (8.0' - 2 \times 0.19') \\&= 1490 \text{ lbs/sf}\end{aligned}$$

#### Note:

*The external analysis above is limited to simple overturning, sliding, applied bearing pressure and bearing capacity for the reinforced mass based on a level toe. No attempt has been made to evaluate the more complicated geotechnical concerns of settlement and global stability. Geotechnical site and soils evaluation is a site-specific art and cannot be programmed.*

### 10) Bearing Capacity

#### Equation (3k)

$$Q_{ult} = cN_c + \gamma D N_q + 0.5 \gamma BN \gamma$$

where:

$$\begin{aligned}N_c &= 30.14, N_q = 18.4, N_\gamma = 22.40 \\B &= (B - 2e) = (8.0' - 2 \times 0.19') = 7.62' \\D &= 1.0' \text{ level embedment} \\c &= 0 \\Q_{ult} &= 0 + (120)(1)(18.4) + (0.5)(120)(7.62)(22.40) \\&= 12449 \text{ psf} \\FS_{br} &= 12449/1490 = 8.36 > 2.0 \text{ OK}\end{aligned}$$



## NCMA 3RD EDITION - COULOMB METHODOLOGY LEVEL SURCHARGE - 250 PSF

**Internal Stability** - The internal analysis must look at the maximum loads at each grid level, connection strength, pullout resistance, and local stability concerns:

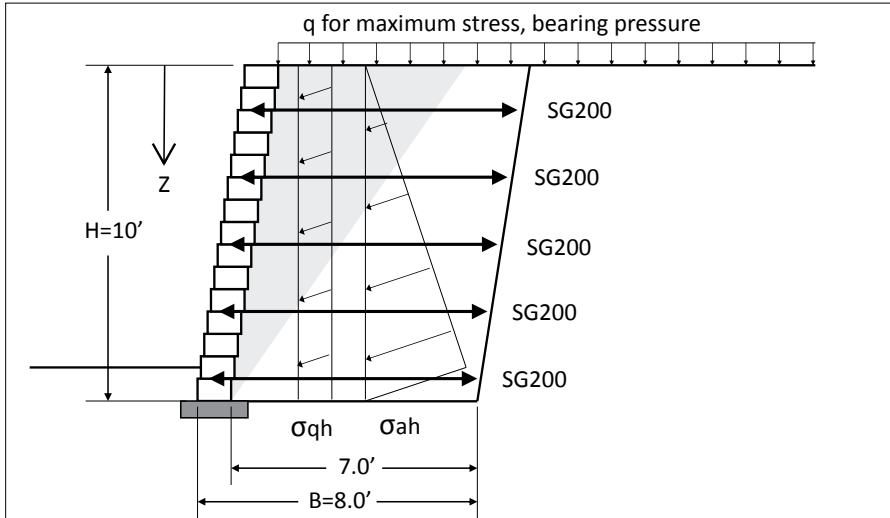

### INTERNAL STABILITY ANALYSIS - LEVEL, 250 PSF SURCHARGE

The internal earth pressure at any level is calculated as follows:

$$\begin{aligned}\sigma_{ah} &= \gamma Z k_a \cos(\delta - i) \\ &= (120 \text{pcf})(Z)(0.207) \cos(22.67 - 7.10) \\ &= 23.9(Z) \text{ psf/lf} \\ \sigma_{qh} &= q k_a \cos(\delta - i) \\ &= (250 \text{psf})(0.207) \cos(22.67 - 7.10) \\ &= 49.9 \text{ psf/lf}\end{aligned}$$

The calculated pressure is applied to the tributary area of each reinforcement level that determines the tensile load in the geogrid reinforcement.



**NCMA 3RD EDITION -  
COULOMB METHODOLOGY LEVEL SURCHARGE - 250 PSF**

11) Maximum Grid Tension

The calculated grid tensions (plf) are tabulated below:

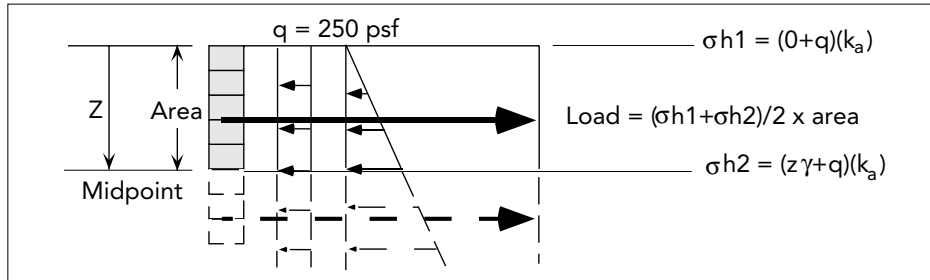

	GRID	DEPTH	z	σah	σqh	σtot	Ave	Area	Load
		TOP	0.0'	0.0	49.9	49.9			
5)	SG200	1.33'					78	2.33'	182
		MID	2.33'	55.7	49.9	105.6			
4)	SG200	3.33'					130	2.00'	260
		MID	4.33'	103.5	49.9	153.4			
3)	SG200	5.33'					177	2.00'	354
		MID	6.33'	151.3	49.9	201.2			
2)	SG200	7.33'					225	2.00'	450
		MID	8.33'	199.1	49.9	249.0			
1)	SG200	9.33'					269	1.67'	449
		BOTTOM	10.0'	239.0	49.9	288.9			

Strata SG200 has an allowable design capacity of 1280 plf from the first page which is greater than the calculated value at each level. Therefore, Strata SG200 is OK for all four levels in tension.



**NCMA 3RD EDITION -  
COULOMB METHODOLOGY LEVEL SURCHARGE - 250 PSF**

12) Pullout Resistance

Pullout safety factors are determined on a level-by-level basis. The effective lengths and calculated pullout is determined at each level and compared to a safety factor of 1.5.

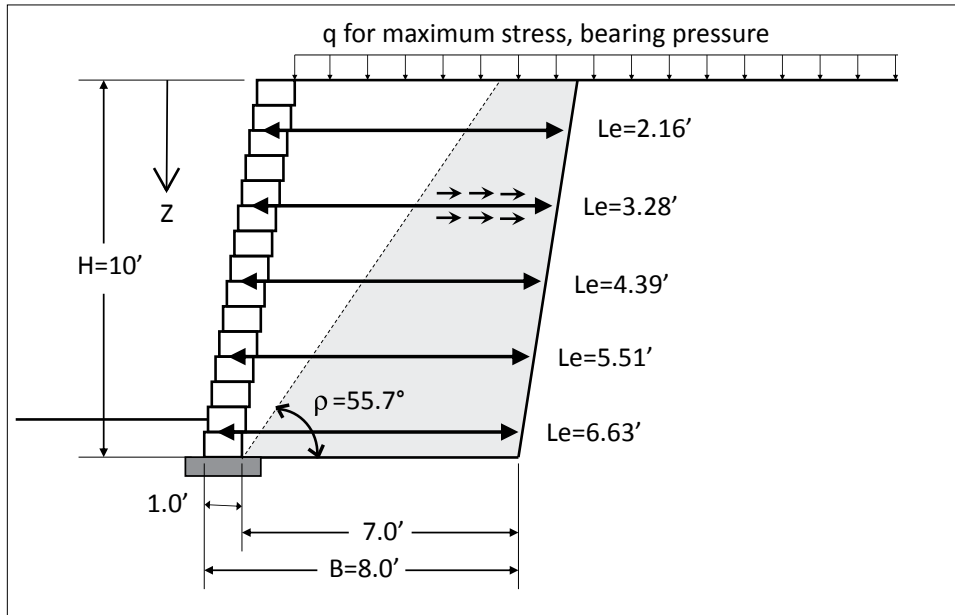

**LEVEL-BY-LEVEL PULLOUT ANALYSIS**

Check each grid level for available pullout resistance against previously calculated tensile loads. Surcharge is not considered as a resisting force under NCMA guidelines:

**Pullout Resistance** =  $(\gamma H_{ov}) (2L_e) (\tan(\phi) C_i)$  with  $H_{ov}$  = average height of overburden.

$L_e = L - \text{Height} / \tan \rho + \text{Height} \times \tan \tau$

	Height	Grid	Hov	$\gamma$	$L_e$	Tan34	$C_i$	Pullout	Load	$FS_{po}$
4)	8.67'	SG200	1.33	120	2.16	.674	0.90	418	182	2.30
4)	6.67'	SG200	3.33	120	3.28	.674	0.90	1590	260	6.12
3)	4.67'	SG200	5.33	120	4.39	.674	0.90	3406	354	9.62
2)	2.67'	SG200	7.33	120	5.51	.674	0.90	5880	450	13.07
1)	0.67'	SG200	9.33	120	6.63	.674	0.90	9006	449	20.05

OK - All pullout safety factors are greater than 1.5.





## NCMA 3RD EDITION - COULOMB METHODOLOGY LEVEL SURCHARGE - 250 PSF

### 13) Connection Strength

The last major item to check is the geogrid connection strength. KeyWallPRO incorporates the laboratory connection test data for all Keystone unit types connected to different geogrid types. The following chart is applicable for Regal Stone Pro® units and Stratagrid SG200 geogrid in this example:

$$\text{Connection} = \text{cs1} + N \times S1 \text{ up to } N = \text{IP-1}$$

where:

$$S1 = (\text{cs2} - \text{cs1}) / \text{IP-1}$$

$$N > \text{IP-1} = \text{cs2} + (N - \text{IP-1}) \times S2 < \text{csMax}$$

where:

$$S2 = (\text{csMax} - \text{cs2}) / (\text{IP-2} - \text{IP-1})$$

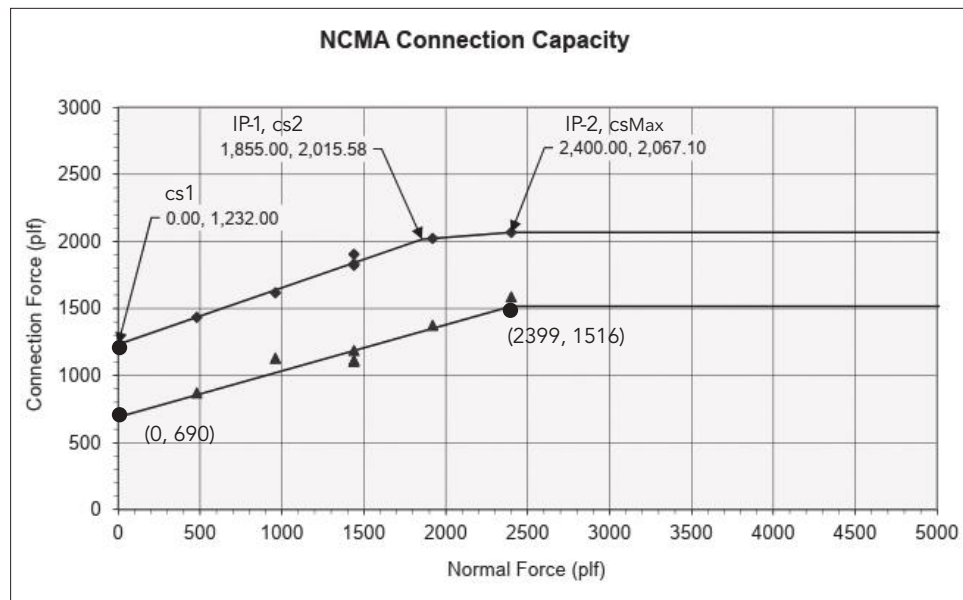

The equations for these connection curves are:

$$\text{Peak Connection} = 1232 \text{ plf} + N \times 0.422 \text{ up to } N = 1855 \text{ plf}$$

$$N > 1855 \text{ plf} = 2015.6 + (N - 1855) \times 0.095 < 2067 \text{ plf max}$$

$$\frac{3}{4}'' \text{ Serviceability} = 690 \text{ plf} + N \times 0.344 < 1516 \text{ plf max}$$

	Height	Grid	Depth	N	Tpeak	TServ	Load	FScorr
5)	8.67'	SG200	1.33'	160	1300	745	182	7.14
4)	6.67'	SG200	3.33'	400	1401	828	260	5.39
3)	4.67'	SG200	5.33'	640	1502	910	354	4.24
2)	2.67'	SG200	7.33'	880	1604	993	450	3.56
1)	0.67'	SG200	9.33'	1120	1705	1076	449	3.80

OK - Connection factor of safety is above 1.50.



## **NCMA 3RD EDITION - COULOMB METHODOLOGY LEVEL SURCHARGE - 250 PSF**

### **14) Crest Toppling**

The KeyWallPRO program also checks the spacing between geogrid levels and the cantilever at the top of wall against the stability of the facing units. Regal Stone Pro units are typically spaced no greater than 3 blocks between geogrid levels to remain stable during construction and eliminate concerns over local stability. The cantilever at the top of wall is also checked against the final loading condition as a small gravity wall. By inspection, the two-unit 1-inch setback cantilever is ok with the 250 psf surcharge, and the three-block maximum spacing between geogrids will be stable during construction and in the final design condition.

### **15) Internal Compound Stability**

Consult the NCMA 3rd Edition example calculation for internal compound stability calculation procedures.

#### **Summary**

The hand calculations verify the attached computer output. The data and methods conform to the NCMA 3rd Edition design method.



**PART SIX**  
Appendix B

**NCMA 3RD EDITION -  
COULOMB METHODOLOGY LEVEL SURCHARGE - 250 PSF**

Project: Keystone Design Manual - Appendix B [Rev. 1] NA Wall: Soil Reinforced Wall, Level Surcharge, NCMA 3rd Edition

**Section** Soil Reinforced Wall, Level Surcharge, NCMA 3rd Edition  
**Report Date** October 24, 2019  
**Designer** JLG  
**Design Standard** National Concrete Masonry Association 3rd Edition  
**Design** Static  
**Unit of Measure** U.S./Imperial  
**Selected Facing Unit** Product Line: Keystone Lip/Lug Systems  
 Name: Regal Stone Pro  
**Seismic As** N/A

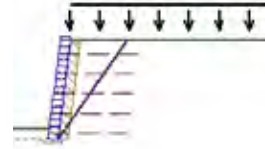

Soil Parameters	Phi Angle [degrees]	Cohesion [lb/ft <sup>2</sup> ]	Unit Weight [lb/ft <sup>3</sup> ]	Description
Reinforced	34	n/a	120.00	
Retained	30	0.00	120.00	
Foundation	30	0.00	120.00	
Leveling Pad	40	n/a	n/a	
Drainage	38	n/a	0.70	

**Section Details**

Section Height	10.33	Back Slope	0.00°	LL Surcharge	250	DL Surcharge	0
Design Height	10.00 ft	Crest Offset	0.00 ft	LL Offset	0.00 ft	DL Offset	0.00 ft
Embedment	1.00 ft	Wall Batter	7.10°	Toe Slope	0.00°	Toe Offset	0.00 ft

**Minimum Factors of Safety**

External	Value	Internal	Value	Facing	Value
FSsl Base Sliding	1.50	FSsl Internal Sliding	1.50	FSCs Connection Strength	1.50
FSbc Bearing Capacity	2.00	FSpO Pullout	1.50	FSSc Facing Shear	1.50
FSct Crest Toppling	1.50	FSto Tensile Overstress	1.50		
FSot Overturning	2.00				

**Reinforcements**

**SG200 - StrataGrid 200** Supplier: Strata Systems - Stratagrid, Fill Type: Sands

Tult	3,600.00 lb/ft	RFcr	1.55	RFd	1.10	LTDS	1,919.49 lb/ft
RFid	1.10	Cds	0.90	Ci	0.90		

**Connection/Shear Properties**

acs1	1,232.00 lb/ft	IP-1	1,855.00 lb/ft	acs2	2,015.58 lb/ft	IP-2	2,400.00 lb/ft
acs max	2,067.10 lb/ft	au	1,260.00 lb/ft	lu	37.00 lb/ft	Vu(max)	3,973.00 lb/ft

**Analysis Results**

- \* Analysis does not include Vertical Forces
- \* Uses External Horiz. Accel Coeff in Seismic Crest Toppling
- \* Embedment is included in Bearing Capacity

**External Static** **FS**

Bearing Capacity	8.37	Bearing Pressure	1487.97 lb/ft <sup>2</sup>
Overturning	5.97	Max Eccentricity	0.19 ft
Base Sliding	2.88		
Crest Toppling	2.09		
Internal Sliding	4.01		

**Internal Static**

Layer	Elevation	Rein	Length	Load	Tensile Resist.	Tensile FS	Pullout Resist.	Pullout FS	Conn. Resist.	Conn. FS
5	8.67	SG200	8.00	182	1,919	10.56	419	2.31	1,300	7.15
4	6.67	SG200	8.00	260	1,919	7.39	1,590	6.12	1,401	5.40
3	4.67	SG200	8.00	356	1,919	5.40	3,413	9.60	1,502	4.23
2	2.67	SG200	8.00	451	1,919	4.25	5,887	13.04	1,604	3.55
1	0.67	SG200	8.00	449	1,919	4.27	9,012	20.05	1,705	3.79

NOTE: THESE CALCULATIONS, QUANTITIES, AND LAYOUTS ARE FOR PRELIMINARY DESIGN ONLY AND SHOULD NOT BE USED FOR CONSTRUCTION WITHOUT REVIEW BY A QUALIFIED ENGINEER



Powered by KeyWallPRO

Page 2

Printed 10/24/2019  
Version: 1.40.12.1050

# PART SIX



## APPENDIX C

*Rockland Ridge Phase II, Baltimore, Maryland; Keystone Standard® - Tri-plane*

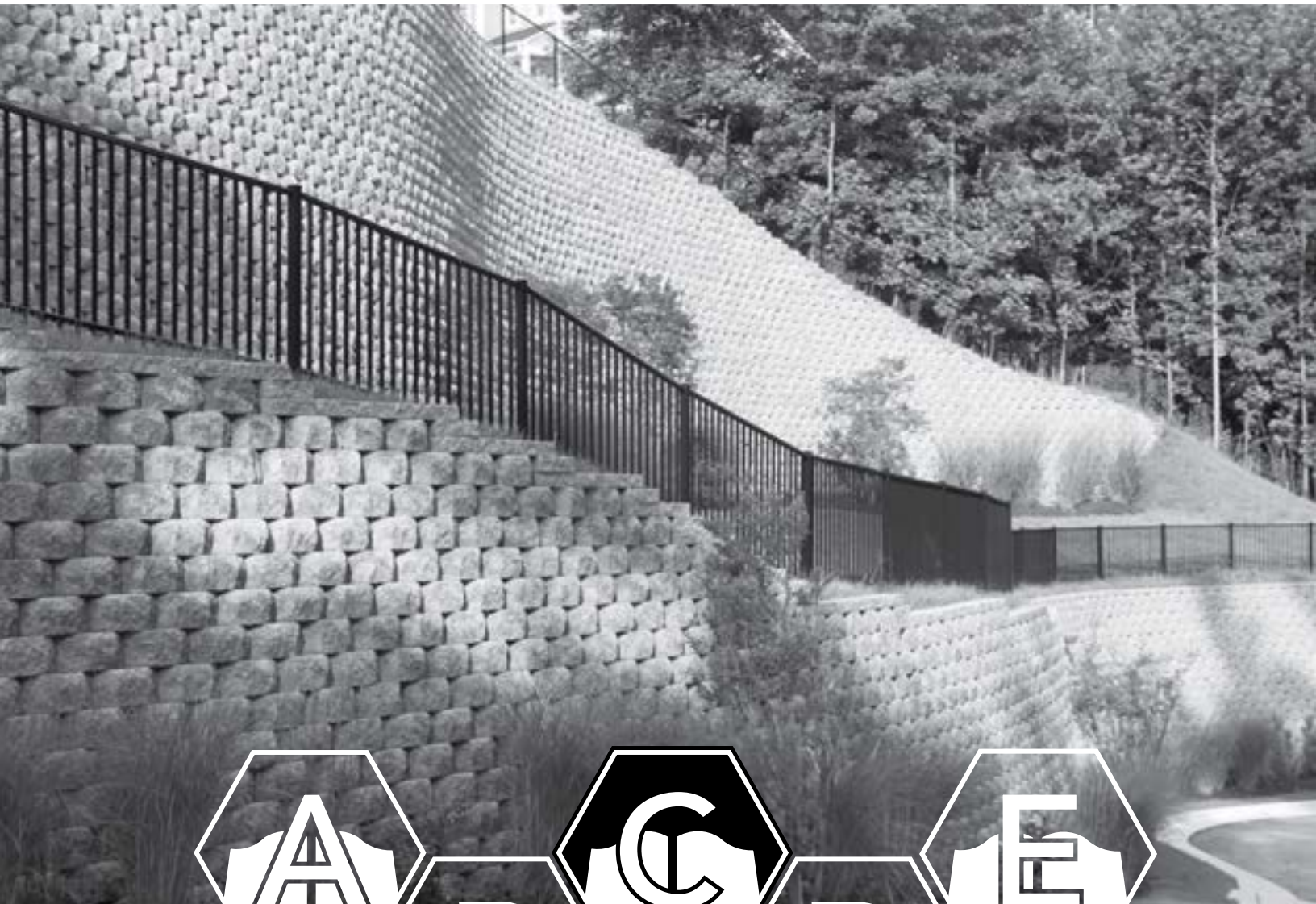



## RANKINE METHODOLOGY LEVEL SURCHARGE - 250 PSF

This set of calculations is intended to verify the KeyWallPRO program output of a typical reinforced soil wall design section. The design follows the Rankine procedure outlined previously in the Keystone Design Manual. The pertinent design information is summarized below:

### 1) General Design Data

Keystone Standard III Units (120 pcf with drainage fill and  $W_u = 1.75'$ )

Stratagrid SG200 Polyester Geogrid

Wall Batter(t) =  $0^\circ$ , near-vertical orientation

Design Height = 10' (9' exposed + 1' embedment)

Base Length, B = 8.5' (uniform lengths chosen for simplicity)

Backslope,  $\beta = 0$ , level backslope

Surcharge = 250 psf (typical roadway surcharge)

### 2) Soil Parameters (*degrees, psf, pcf*)

SOIL PARAMETERS	$\phi$	c	$\gamma$
Reinforced Soil	34	0	120
Retained Soil	30	0	120
Foundation Soil	30	0	120

### 3) Geogrid Design Parameters (*plf*)

Geogrid	$T_{ult}$	$RF_{cr}$	$RF_d$	$RF_{id}$	LTDS	FS	$T_{al}$
Strata SG200	3600	1.55	1.10	1.10	1919	1.5	1280plf

( $C_i$  &  $C_d = 0.90$  for select backfill )

### 4) Geometric Parameters - Rankine

#### Internal

$\phi = 34$  degrees  
 $\delta = \beta = 0$  degrees (no backslope)  
 $\alpha = 90$  degrees (90° + no batter)  
 $\beta = 0$  degrees (level)

#### External

$\phi = 30$  degrees  
 $\delta = \beta = 0$  degrees (no backslope)  
 $\alpha = 90$  degrees (90° + no batter)  
 $\beta = 0$  degrees (level)



## RANKINE METHODOLOGY LEVEL SURCHARGE - 250 PSF

### 5) Rankine Earth Pressure Calculation

#### Internal

##### Equation (3g)

$$k_a = \tan^2(45 - \phi/2)$$

$$k_a = 0.283 \text{ for above parameters - Rankine}$$

##### Equation (3h)

$$\rho = 45 + \phi/2$$

$$\rho = 62.0^\circ \text{ for above parameters - Rankine}$$

#### External

##### Equation (3g)

$$k_a = \tan^2(45 - \phi/2)$$

$$k_a = 0.333 \text{ for above parameters - Rankine}$$

#### External Forces

##### Equation. (3e)

$$P_a = \frac{1}{2} \gamma H^2 k_a$$

$$P_{ah} = \frac{1}{2} \gamma H^2 k_a \cos(\beta) - \text{Horizontal Component}$$

$$P_{ah} = (0.5)(120 \text{ pcf})(10')^2 (0.333) \cos(0)$$

$$P_{ah} = 2000 \text{ lbs/lf}$$

##### Equation. (3f)

$$P_q = qH k_a$$

$$P_{qh} = qH k_a \cos(\beta) - \text{Horizontal Component}$$

$$P_{qh} = (250 \text{ psf})(10')(0.333) \cos(0)$$

$$P_{qh} = 833 \text{ lbs/lf}$$

#### External Masses

$$W_f = W_u H \gamma = (1.75')(10')(120 \text{ pcf}) = 2100 \text{ lbs/lf}$$

$$W_l = (B - W_u) H \gamma = (8.5' - 1.75')(10')(120 \text{ pcf}) = 8100 \text{ lbs/lf}$$

$$W_q = q (B - W_u) = (250 \text{ psf})(8.5' - 1.75') = 1688 \text{ lbs/lf}$$



## RANKINE METHODOLOGY LEVEL SURCHARGE - 250 PSF

External Stability Diagram

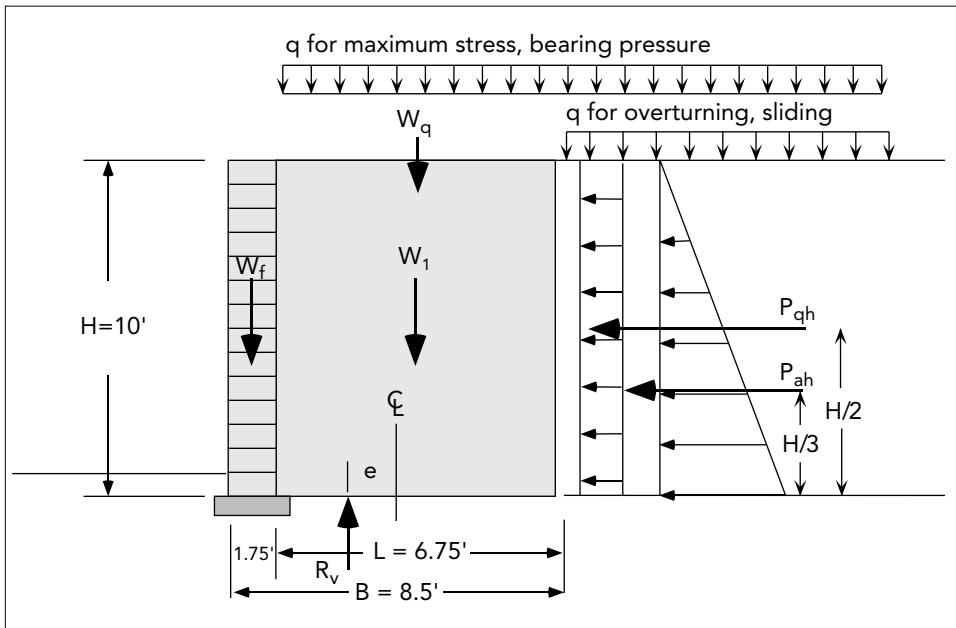

### 6) Overturning

#### Overturning Moment

$$\begin{aligned} M_o &= P_{ah} (H/3) + P_{qh} (H/2) \\ &= 2000 \text{ lbs} (10/3) + 833 \text{ lbs} (10/2) \\ &= 10832 \text{ ft-lbs} \end{aligned}$$

#### Resisting Moment

$$\begin{aligned} M_r &= W_f \times W_u / 2 + W_1 \times (W_u + L / 2) \\ &= (2100 \times 1.75 / 2) + 8100(1.75' + 6.75' / 2) \\ &= 43350 \text{ ft-lbs} \end{aligned}$$

$$FS_{ot} = M_r / M_o = 43350 / 10832 = 4.00 > 1.5 \text{ OK}$$



## RANKINE METHODOLOGY LEVEL SURCHARGE - 250 PSF

### 7) Base Sliding

#### Lateral Driving Forces

$$\begin{aligned} R_d &= P_{ah} + P_{qh} \\ &= 2000 \text{ lbs} + 833 \text{ lbs} \\ &= 2833 \text{ lbs/ft} \end{aligned}$$

#### Lateral Resisting Forces

$$\begin{aligned} R_r &= (W_f + W_i) \times \tan \phi \text{ of foundation} \\ &= (2100 + 8100) \times 0.577 \\ &= 5885 \text{ lbs/ft} \\ FS_{sl} &= R_r / R_d = 5885 / 2833 = 2.08 > 1.5 \text{ OK} \end{aligned}$$

### 8) Sliding at Lowest Reinforcement Level

#### Lateral Driving Forces (at depth of 9.33')

$$\begin{aligned} R_d &= P_{ah} + P_{qh} \\ &= 1741 \text{ lbs} + 777 \text{ lbs} \\ &= 2518 \text{ lbs/ft} \end{aligned}$$

#### Lateral Resisting Forces (at depth of 9.33')

$$\begin{aligned} \tau_{unit} &= 1500 + N \tan 32 \\ &= 1500 \text{ plf} + (9.33' \times 1.75' \times 120 \text{ pcf}) \tan 32 \\ &= 2724 \text{ plf} \\ \tau_{soil} &= (\gamma H (B - W_u)) \times \tan \phi \text{ (of reinforced material)} \times C_{ds} \\ &= 120 \text{ pcf} \times 9.33' \times 6.75' \times 0.675 \times 0.90 \\ &= 4591 \text{ lbs/ft} \\ FS_{sl} &= R_r / R_d = (2724 + 4591) / 2518 = 2.91 > 1.5 \text{ OK} \end{aligned}$$





## RANKINE METHODOLOGY LEVEL SURCHARGE - 250 PSF

### 9) Bearing Pressure *(Note: Live load is added for Applied Bearing Pressure)*

#### Eccentricity

##### Equation (3i)

$$\begin{aligned}
 e &= B / 2 - (M_r - M_o) / R_v \\
 M_r &= 43350 \text{ ft-lbs (from overturning calculation)} \\
 R_v &= W_f + W_1 \\
 &= (2100 + 8100) = 10200 \text{ lbs/ft} \\
 e &= 8.5' / 2 - (43350 - 10832) / 10200 \\
 &= 1.06'
 \end{aligned}$$

#### Applied Bearing Pressure

##### Equation (3j)

$$\begin{aligned}
 \sigma_v &= R_v / (L - 2e) \\
 R_v &= W_f + W_1 + W_q \\
 &= (2100 + 8100 + 1688) = 11888 \text{ lbs/ft} \\
 \sigma_v &= (11888) / (8.5' - 2 \times 1.06') \\
 &= 1863 \text{ lbs/sf}
 \end{aligned}$$

### 10) Bearing Capacity

#### Equation (3k)

$$\begin{aligned}
 Q_{ult} &= cN_c + \gamma DN_q + 0.5\gamma(B - 2)N_\gamma \\
 \text{where:} \\
 N_c &= 30.14, N_q = 18.4, N_\gamma = 22.40 \\
 B &= (B - 2e) = (8.5' - 2 \times 1.06) = 6.38' \\
 D &= 1.0' \text{ level embedment} \\
 c &= 0 \\
 Q_{ult} &= 0 + (120)(1)(18.4) + (0.5)(120)(6.38)(22.40) \\
 &= 10783 \text{ psf} \\
 FS_{br} &= 10738 / 1863 = 5.79 > 2.0 \text{ OK}
 \end{aligned}$$

#### Note:

*The external analysis is limited to simple overturning, sliding, applied bearing pressure and bearing capacity for the reinforced mass based on a level toe. No attempt has been made to evaluate the more complicated geotechnical concerns of settlement and global stability. Geotechnical site and soils evaluation is a site-specific art and cannot be programmed.*



## RANKINE METHODOLOGY LEVEL SURCHARGE - 250 PSF

**Internal Stability** - The internal analysis must look at the maximum loads at each grid level, connection strength, pullout resistance, and local stability concerns:

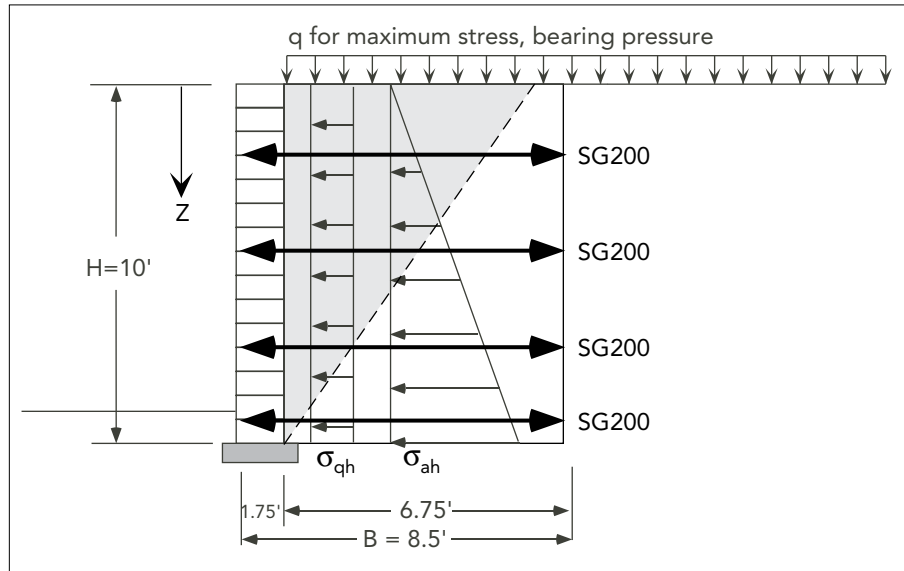

The internal earth pressure at any level is calculated as follows:

$$\begin{aligned}\sigma_{ah} &= \gamma Z k_a \cos(\beta) \\ &= (120\text{pcf})(Z)(0.283) \cos(0) \\ &= \mathbf{34.0 (Z) \text{ plf}} \\ \sigma_{qh} &= qk_a \cos(\beta) \\ &= (250\text{psf})(0.283) \cos(0) \\ &= \mathbf{70.8 \text{ plf}}\end{aligned}$$

The calculated pressure is applied to the tributary area of each reinforcement level which determines the tensile load in the geogrid reinforcement.



**RANKINE METHODOLOGY LEVEL SURCHARGE - 250 PSF**

11) Maximum Grid Tension

The calculated grid tensions (plf) are tabulated below:

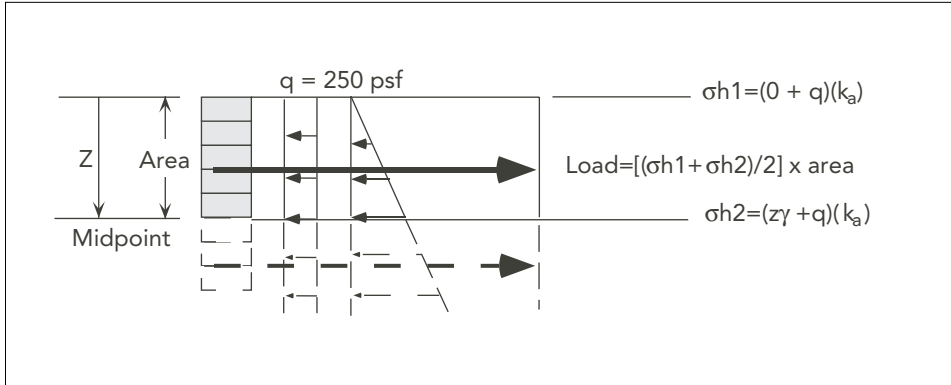

	GRID	DEPTH	z	$\sigma_{ah}$	$\sigma_{qh}$	$\sigma_{tot}$	Ave	Area	Load
		TOP	0.0	0.0	70.8	71			
4)	SG200	2.00'					127	3.33	425
		MID	3.33	113	70.8	184			
3)	SG200	4.67'					229	2.67	611
		MID	6.00	204	70.8	275			
2)	SG200	7.33'					314	2.33	732
		MID	8.33	283	70.8	354			
1)	SG200	9.33'					382	1.67	637
		BOTTOM	10.00	340	70.8	411			

Strata SG200 has an allowable design capacity of 1280 plf from the first page which is greater than the calculated value at each level. Therefore, Strata SG200 is OK for all four levels in tension.



## RANKINE METHODOLOGY LEVEL SURCHARGE - 250 PSF

### 12) Pullout Resistance

Pullout safety factors are determined on a level-by-level basis. The effective lengths and calculated pullout is determined at each level and compared to a safety factor of 1.5.

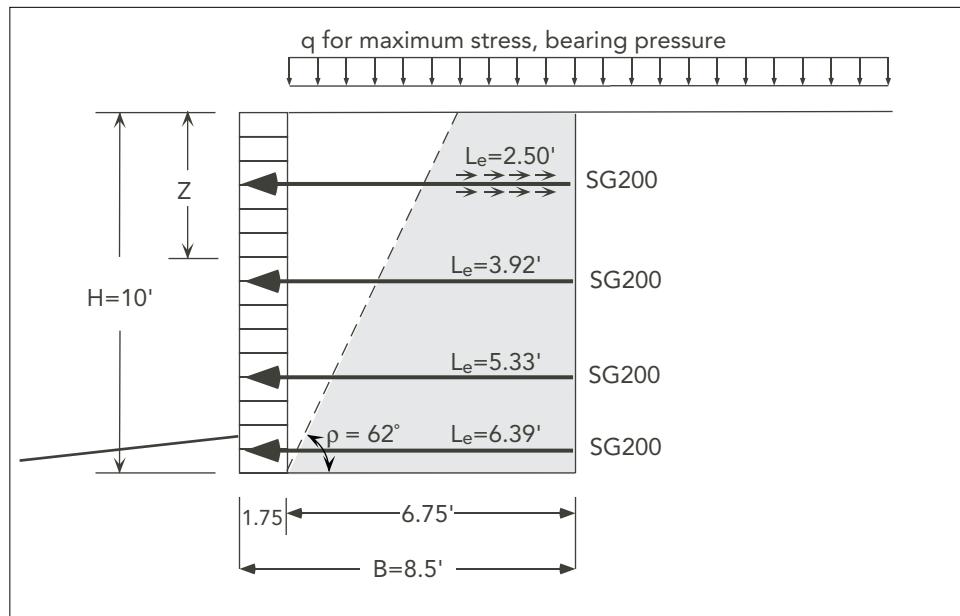

Check each grid level for available pullout resistance against previously calculated tensile loads. A live load surcharge is not considered as a resisting force:

**Pullout Resistance** =  $(\gamma H_{ov}) (2L_e) (\tan(\phi)C_i)$  with  $H_{ov}$  = average height of overburden.

$L_e = (L - \text{Height} / \tan \rho)$

	Height	Grid	$H_{ov}$	$\gamma$	$L_e$	Tan34	$C_i$	Pullout Load	$FS_{po}$
4)	8.00'	SG200	2.00	120	2.50	.674	0.90	728 425	1.71
3)	5.33'	SG200	4.67	120	3.93	.674	0.90	2665 611	4.36
2)	2.67'	SG200	7.33	120	5.33	.674	0.90	5688 732	7.77
1)	0.67'	SG200	9.33	120	6.39	.674	0.90	8680 637	13.63

OK - All pullout safety factors are greater than 1.5



## RANKINE METHODOLOGY LEVEL SURCHARGE - 250 PSF

### 13) Connection Strength

The last major item to check is the geogrid connection strength. KeyWallPRO incorporates the laboratory connection test data for all Keystone unit types connected to different geogrid types. The following chart is applicable for Keystone Standard III units and Stratagrid SG200 geogrid in this example:

$$\text{Connection} = cs1 + N \times S1 < csMax$$

where:

$$S1 = (csMax - cs1) / IP-1$$

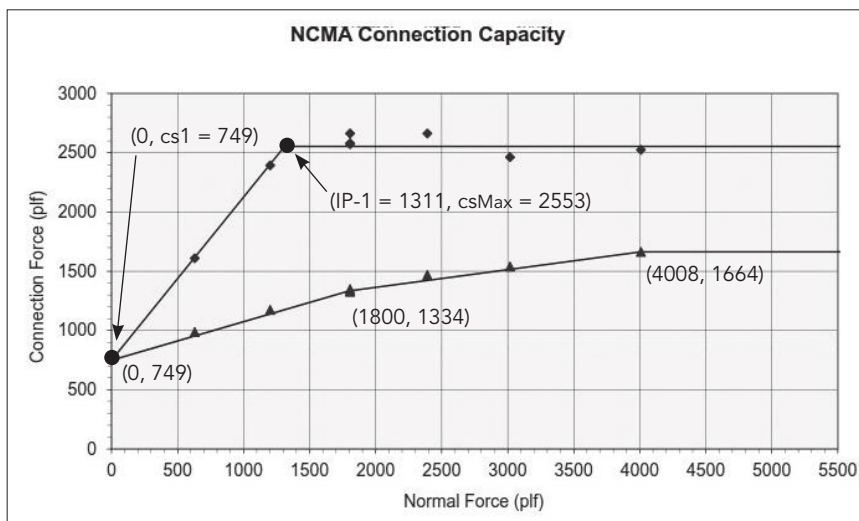

The equations for these connection curves are:

$$\text{Peak Connection} = 749 \text{ plf} + N \times 1.376 < 2553 \text{ plf}$$

$$\text{3/4" Serviceability} = 749 \text{ plf} + N \times 0.325 \text{ up to } N = 1800 \text{ plf}$$

$$N > 1800 \text{ plf} = 1334 + N \times 0.149 < 1664 \text{ plf max}$$

	Height	Grid	Depth	N	Tpeak	TServ	Load	FSconn
4)	8.00'	SG200	2.00'	420	758	885	425	3.12
3)	5.33'	SG200	4.67'	981	1027	1067	611	3.44
2)	2.67'	SG200	7.33'	1539	1045	1249	732	3.49
1)	0.67'	SG200	9.33'	1959	1045	1362	637	4.01

OK - Connection Factor of Safety is above 1.50.

(Rankine method does not check serviceability as the default setting.)



## **RANKINE METHODOLOGY LEVEL SURCHARGE - 250 PSF**

### 14) Other Design Checks

The KeyWallPRO program also checks the spacing between geogrid levels and the cantilever at the top of wall against the stability of the facing units. Standard Keystone III units are typically spaced no greater than 4 blocks between geogrid levels to remain stable during construction and eliminate concerns over local stability. The cantilever at the top of wall is also checked against the final loading condition as a small gravity wall. By inspection, the three-unit vertical cantilever is ok with the 250 psf surcharge and the four-block maximum spacing between geogrids will be stable during construction and in the final design condition.

#### **Summary**

The hand calculations verify the attached computer output. The data and methods conform to the Rankine design method as outlined in the Keystone Design Manual.



## RANKINE METHODOLOGY LEVEL SURCHARGE - 250 PSF

Project: Keystone Design Manual - Appendix C [Rev. 1] NA				Wall: Soil Reinforced Wall, Level Surcharge, Rankine			
<b>Section</b>	Soil Reinforced Wall, Level Surcharge, Rankine						
<b>Report Date</b>	October 24, 2019						
<b>Designer</b>	JLG						
<b>Design Standard</b>	Rankine Theory Analysis						
<b>Design</b>	Static						
<b>Unit of Measure</b>	U.S./Imperial						
<b>Selected Facing Unit</b>	Product Line: Keystone Pinned Systems Name: Standard III 21						
<b>Seismic As</b>	N/A						

Soil Parameters	Phi Angle [degrees]	Cohesion [lb/ft <sup>2</sup> ]	Unit Weight [lb/ft <sup>3</sup> ]	Description
Reinforced	34	n/a	120.00	
Retained	30	0.00	120.00	
Foundation	30	0.00	120.00	
Leveling Pad	40	n/a	n/a	
Drainage	38	n/a	0.70	

Section Details							
Section Height	10.33	Back Slope	0.00°	LL Surcharge	250	DL Surcharge	0
Design Height	10.00 ft	Crest Offset	0.00 ft	LL Offset	0.00 ft	DL Offset	0.00 ft
Embedment	1.00 ft	Wall Batter	0.00°	Toe Slope	0.00°	Toe Offset	0.00 ft

Minimum Factors of Safety								
Reinforced								
External	Value	Internal	Value	Facing	Value	Value		
FSl	Base Sliding	1.50	FSl	Internal Sliding	1.50	FScs	Connection Strength	1.50
FSbc	Bearing Capacity	2.00	FSpO	Pullout	1.50	FSSc	Facing Shear	1.50
FSct	Crest Toppling	1.50	FSto	Tensile Overstress	1.50			
FSot	Overturning	2.00						

Reinforcements							
SG200 - StrataGrid 200				Supplier: Strata Systems - Stratagrid, Fill Type: Sands			
Tult	3,600.00 lb/ft	RFcr	1.55	RFd	1.10	LTDS	1,919.49 lb/ft
RFid	1.10	Cds	0.90	Cl	0.90		

Connection/Shear Properties							
acs1	749.00 lb/ft	IP-1	1,311.00 lb/ft	acs2	2,553.44 lb/ft	IP-2	6,000.00 lb/ft
acs max	2,553.44 lb/ft	au	1,500.00 lb/ft	au	32.00 lb/ft	Vu(max)	3,984.00 lb/ft

Analysis Results			
* Embedment is included in Bearing Capacity			
External Static		FS	
Bearing Capacity	5.78	Bearing Pressure	1864.47 lb/ft <sup>2</sup>
Overturning	4.00	Max Eccentricity	1.06 ft
Base Sliding	2.08		
Crest Toppling	2.30		
Internal Sliding	2.90		

Internal Static										
Layer	Elevation	Rein	Length	Load	Tensile Resist.	Tensile FS	Pullout Resist.	Pullout FS	Conn. Resist.	Conn. FS
4	8.00	SG200	8.50	424	1,919	4.53	727	1.72	1,327	3.13
3	5.33	SG200	8.50	611	1,919	3.14	2,661	4.36	2,098	3.44
2	2.67	SG200	8.50	732	1,919	2.62	5,697	7.78	2,553	3.49
1	0.67	SG200	8.50	636	1,919	3.02	8,697	13.67	2,553	4.01

# PART SIX



## APPENDIX D

*Bristol Green, Baltimore County, Maryland; Keystone Compac® - Straight Split*

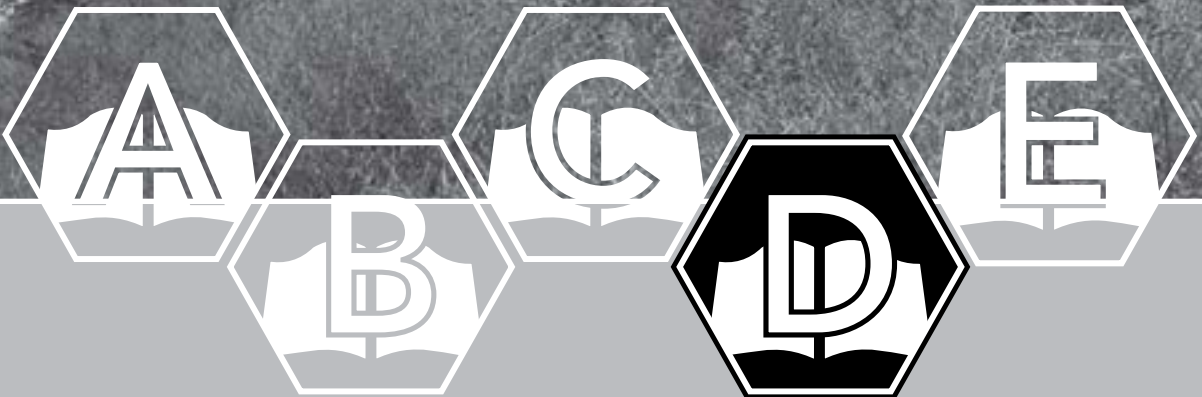
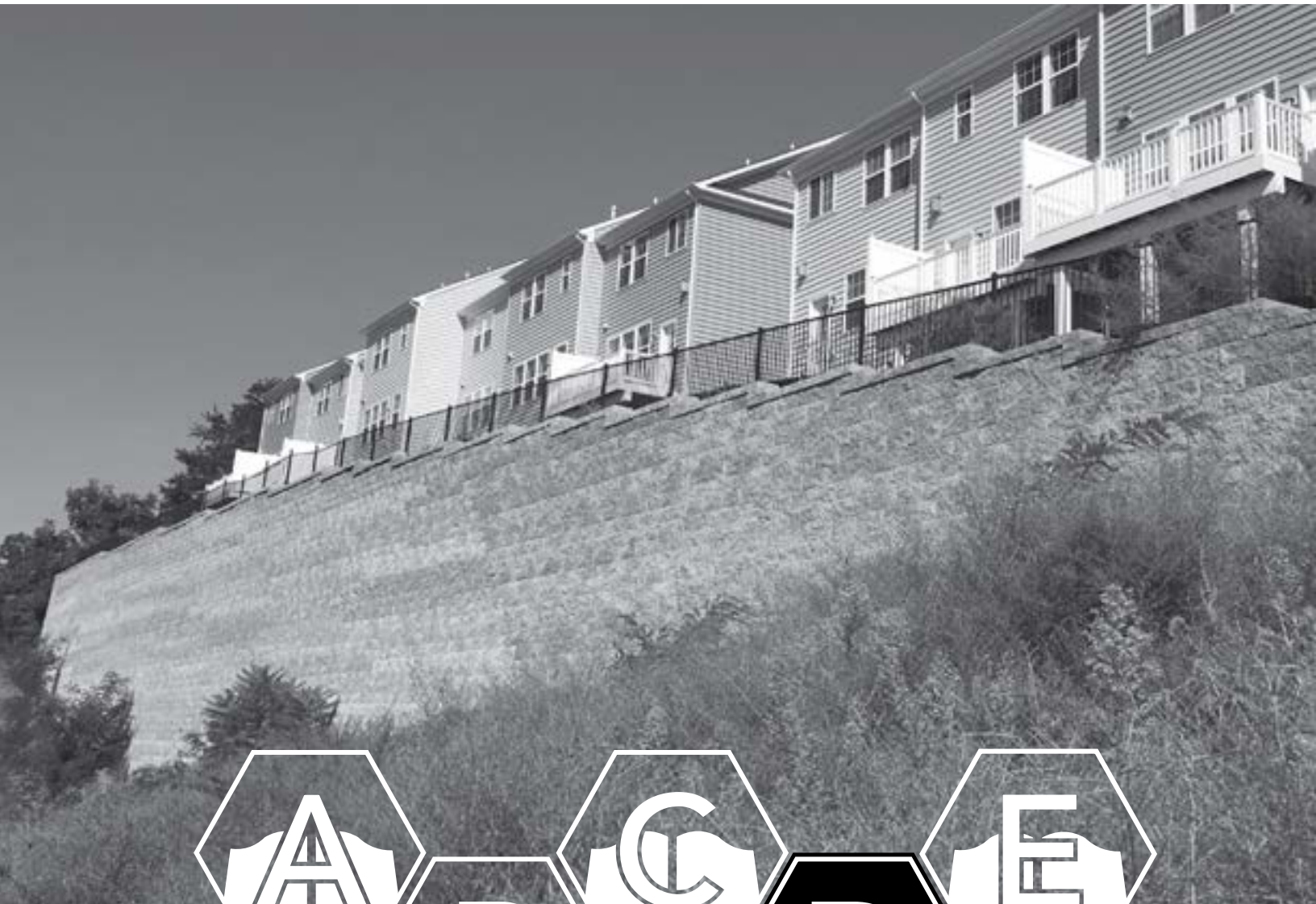





### 3H:1V SLOPING SURCHARGE AASHTO LRFD METHODOLOGY

This set of calculations is intended to verify the KeyWallPRO program output of a typical reinforced soil wall design section. The design follows the basic AASHTO LRFD procedure. The pertinent design information is summarized below:

1) **General Design Data**

Keystone Compac II Units (120 pcf with drainage fill and  $W_u = 1.00'$ )  
 Mirafi 3XT Polyester Geogrid  
 Wall Batter ( $t$ ) =  $0^\circ$ , near-vertical orientation  
 Design Height =  $10'$  ( $8'$  exposed +  $2'$  embedment)  
 Base Length,  $B$  =  $9.0'$  (70% min B/H or  $8'$  minimum)  
 Backslope,  $\beta$  =  $18.4^\circ$ , 3H:1V backslope  
 Surcharge = slope only

2) **Soil Parameters** (*degrees, psf, pcf*)

SOIL PARAMETERS	$\phi$	c	$\gamma$
Reinforced Soil	34	0	120
Retained Soil	30	0	120
Foundation Soil	30	0	120

3) **Geogrid Design Parameters** (*plf*)

Geogrid	$T_{ult}$	$FS_{cr}$	$RF_d$	$RF_{id}$	LTDS	$\phi_{GEO}$	$T_{al}$
Mirafi 3XT	3500	1.60	1.15	1.15	1654	0.90	<b>1489plf</b>

$C_i$  &  $C_d$ s = 0.90 for select backfill  
 $RF_{cn-d} = 1.15$   
 $RF_{cn-cr} = 1.15$

4) **Load and Resistance Factors - Strength 1**

Driving Load Factors	Resisting Load Factors	Resistance Factors
$EH_c = 1.50$	$EH_r = 0.90$	Sliding $RF_{sl} = 1.00$
$EV_d = 1.35$	$EV_r = 1.00$	Bearing $RF_b = 0.65$
$ES_d = 1.50$	$ES_r = 0.75$	Tension $RF_t = 0.90$
$LL_d = 1.75$		Pullout $RF_{po} = 0.90$

5) **Geometric Parameters - AASHTO LRFD**

Internal	External
$\phi$ = 34 degrees	$\phi$ = 30 degrees
$\delta$ = 0 degrees (using equivalent slope)	$\delta$ = $\beta$ = 18.4 degrees
$\alpha$ = 90 degrees ( $90^\circ$ + no batter)	$\alpha$ = 90 degrees ( $90^\circ$ + no batter)
$\beta$ = 0 degrees (using equivalent slope)	$\beta$ = 18.4 degrees (Infinite slope)



### 3H:1V SLOPING SURCHARGE AASHTO LRFD METHODOLOGY

#### 6) Rankine Earth Pressure Calculation

##### Internal

###### Equation (3g)

$$k_a = \tan^2(45 - \phi/2)$$

$$k_a = 0.283 \text{ for above parameters - Rankine}$$

###### Equation (3h)

$$\rho = 45 + \phi/2$$

$$\rho = 62.0^\circ \text{ for above parameters - Rankine}$$

##### External

###### Equation (3g)

$$k_a = \cos \beta \frac{\cos \beta - \sqrt{\cos^2 \beta - \cos^2 \phi}}{\cos \beta + \sqrt{\cos^2 \beta - \cos^2 \phi}}$$

$$k_a = 0.398 \text{ for above parameters - Rankine}$$

##### External Forces

###### Equation (3e)

$$P_a = \frac{1}{2} \gamma HS^2 k_a$$

$$HS = H + (B - W_u) \tan \beta$$

$$HS = 10' + (9' - 1.0') \tan 18.4^\circ$$

$$HS = 12.66'$$

$$P_{ah} = \frac{1}{2} \gamma HS^2 k_a \cos(\beta) - \text{Horizontal Component}$$

$$P_{ah} = (0.5)(120 \text{pcf})(12.66')^2(0.398) \cos(18.4)$$

$$P_{ah} = 3632 \text{ lbs/lf}$$

$$P_{av} = \frac{1}{2} \gamma HS^2 k_a \sin(\beta) - \text{Vertical Component}$$

$$P_{av} = (0.5)(120 \text{pcf})(12.66')^2(0.398) \sin(18.4)$$

$$P_{av} = 1208 \text{ lbs/lf}$$

##### External Masses

$$W_f = W_u H \gamma = (1.00')(10')(120 \text{ pcf}) = 1200 \text{ lbs/lf}$$

$$W_1 = (B - W_u) H \gamma = (9.0' - 1.0')(10')(120 \text{ pcf}) = 9600 \text{ lbs/lf}$$

$$W_2 = \frac{1}{2}(B - W_u)(HS - H) \gamma = \frac{1}{2}(9' - 1.0')(12.66' - 10') 120 \text{ pcf} = 1277 \text{ lbs/lf}$$



### 3H:1V SLOPING SURCHARGE AASHTO LRFD METHODOLOGY

External Stability Diagram

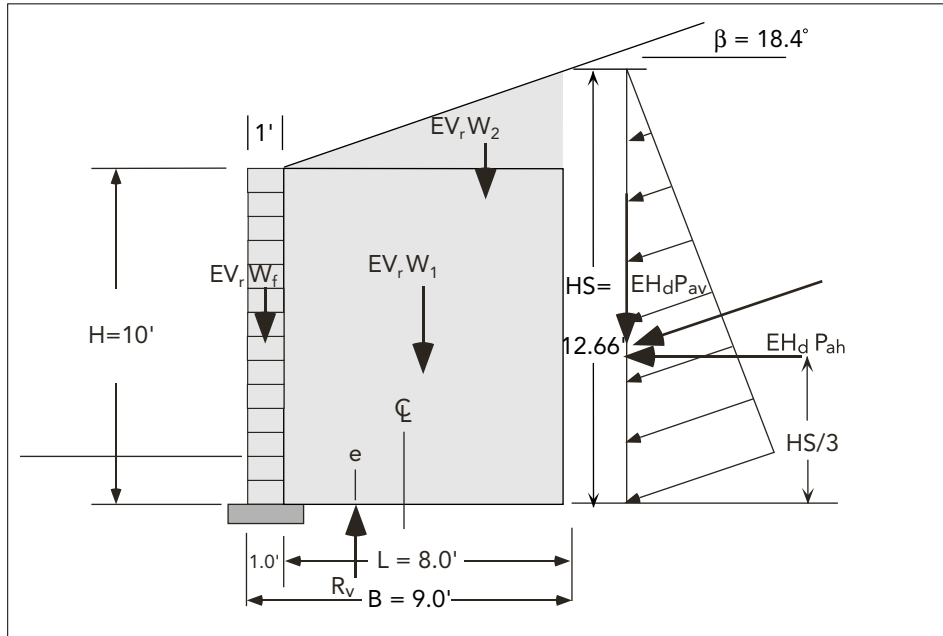

#### 7) Overturning

##### Overturning Moment

$$\begin{aligned} M_o &= E H_d \times P_{ah} (HS/3) \\ &= 1.50 \times 3632 \text{ lbs} (12.66'/3) \\ &= 23003 \text{ ft-lbs} \end{aligned}$$

##### Resisting Moment

$$\begin{aligned} M_r &= E V_r \times W_f \times W_u / 2 + E V_r \times W_1 \times (W_u + L / 2) + E V_r \times W_2 \times (W_u + 2/3L) + E H_d \times P_{av} \times B \\ &= 1.00 \times (1200 \times 1.0'/2) + 1.00 \times 9600(1.0' + 8.0'/2) + 1.00 \times 1277(1.0'+5.33') + 1.50 \times 1208 \times 9' \\ &= 72991 \text{ ft-lbs} \end{aligned}$$

$$CDR_{Ot} = M_r / M_o = 72991/23003 = 3.17 > 1.0 \text{ OK}$$



### 3H:1V SLOPING SURCHARGE AASHTO LRFD METHODOLOGY

#### 8) Base Sliding

##### Lateral Driving Forces

$$\begin{aligned} R_d &= E_{Hd} \times P_{ah} \\ &= 1.50 \times 3632 \text{ lbs} \\ &= \mathbf{5448 \text{ lbs/ft}} \end{aligned}$$

##### Lateral Resisting Forces

$$\begin{aligned} R_r &= [E_{Vr} \times (W_f + W_1 + W_2) + E_{Hd} \times P_{av}] \times \tan \phi \text{ of foundation} \\ &= [1.00 \times (1200 + 9600 + 1277) + 1.50 \times 1208] \times 0.577 \\ &= \mathbf{8014 \text{ lbs/ft}} \\ CDR_{sl} &= R_{fs} \times (R_r / R_d) = 1.00 \times (8014 / 5448) = \mathbf{1.47} > 1.00 \text{ OK} \end{aligned}$$

#### 9) Sliding at Lowest Reinforcement Level

##### Lateral Driving Forces (at depth of 9.33')

$$\begin{aligned} R_d &= E_{Hdx} \times P_{ah} @ 9.33' \\ &= 1.50 \times \frac{1}{2}(120)(9.33' + 2.66')^2 (0.398) \cos 18.4 \\ &= \mathbf{4886 \text{ lbs/ft}} \end{aligned}$$

##### Lateral Resisting Forces (at depth of 9.33')

$$\begin{aligned} \tau_{unit} &= a_u + N \tan \lambda_u < V_u (\max) = 3129 \text{ lbs/ft.} \\ \tau_{unit} &= E_{Vr} \times (1250 + N \tan 29^\circ) \\ &= 1.00 \times [1250 \text{ plf} + (9.33' \times 1.00' \times 120 \text{ pcf}) \tan 29^\circ] \\ &= \mathbf{1871 \text{ plf}} \\ \tau_{soil} &= [E_{Vr} \times (\gamma H (B - W_u)) + E_{Vr} \times W_2 + E_{Hd} \times P_{av}] \times \tan \phi \text{ (of reinforced material)} \times C_{ds} \\ &= [1.00 \times (120 \text{ pcf} \times 9.33' \times 8.0') + 1.00 \times 1277 + 1.50 \times 1208] \times 0.675 \times 0.90 \\ &= \mathbf{7318 \text{ lbs/ft}} \\ CDR_{sl} &= R_{fs} \times (R_r / R_d) = 1.00 \times (1871 + 7318) / 4886 = \mathbf{1.88} > 1.0 \text{ OK} \end{aligned}$$



### 3H:1V SLOPING SURCHARGE AASHTO LRFD METHODOLOGY

#### 10) Bearing Pressure (*Note: Live load is added for e and Max Bearing Pressure*)

Eccentricity - Strength 1 ( $M_r$ ,  $M_o$ , and  $R_v$  use driving load factors for min e)

Equation (3i)

$$\begin{aligned}
 e &= B/2 - (M_r - M_o) / R_v \\
 M_r &= EV_d \times W_f (W_u / 2) + EV_d \times W_1 (W_u + L/2) + EV_d \times W_2 (W_u + 2/3L) + EH_d \times (P_{av} \times B) \\
 &= 1.35 \times 1200(1.00' / 2) + 1.35 \times 9600(1.0' + 8' / 2) + 1.35 \times 1277(1.0 + 5.33') + 1.50 \times (1208 \times 9.0') \\
 &= 92831 \text{ ft-lbs} \\
 M_o &= 23003 \text{ ft-lbs (from overturning calculation)} \\
 R_v &= EV_d \times (W_f + W_1 + W_2) + EV_d \times P_{av} \\
 &= 1.35 \times (1200 + 9600 + 1277) + 1.50 \times 1208 = 18116 \text{ lbs/ft} \\
 e &= 9.0' / 2 - (92831 - 23003) / 18116 \\
 &= 0.65'
 \end{aligned}$$

Max Applied Bearing Pressure - Strength 1 ( $R_v$  uses driving load factors)

Equation (3j)

$$\begin{aligned}
 \sigma_v &= R_v / (B - 2e) \\
 &= 18116 / (9.0' - 2 \times 0.65') \\
 &= 2353 \text{ lbs/sf}
 \end{aligned}$$

Eccentricity - Strength 1 (*from overturning calculation*)

Equation (3i)

$$\begin{aligned}
 e &= B/2 - (M_r - M_o) / R_v \\
 M_r &= 72991 \text{ ft-lbs (from overturning calculation)} \\
 M_o &= 23003 \text{ ft-lbs (from overturning calculation)} \\
 R_v &= EV_r \times (W_f + W_1 + W_2) + EH_d \times P_{av} \\
 &= 1.00 \times (1200 + 9600 + 1277) + 1.50 \times 1208 = 13889 \text{ lbs/ft} \\
 e &= 9.0'/2 - (72991 - 23003) / 13889 \\
 &= 0.90' < B/4 = 9.0' / 4 = 2.25' \text{ OK}
 \end{aligned}$$

**Note:**

Earth pressure  $P_a$  uses EH load factor for both force components  $P_{ah}$  and  $P_{av}$  per the AASHTO LRFD code.

**Note:**

The external analysis is limited to simple overturning, sliding, applied bearing pressure and bearing capacity for the reinforced mass based on a level toe. No attempt has been made to evaluate the more complicated geotechnical concerns of settlement and global stability. Geotechnical site and soils evaluation is a site-specific art and cannot be programmed.



### 3H:1V SLOPING SURCHARGE AASHTO LRFD METHODOLOGY

#### 10) Bearing Pressure (*continued*)

Eccentricity - Service 1 (*no load factors*)

Equation (3i)

$$\begin{aligned} e &= B/2 - (M_r - M_o) / R_v \\ M_r &= W_f (W_u / 2) + W_1 (W_u + L/2) + W_2 (W_u + 2/3L) + P_{av} \times B \\ &= 1200 (1.00'/2) + 9600 (1.0' + 8'/2) + 1277 (1.0 + 5.33) + 1208 \times 9' \\ &= 67555 \text{ ft-lbs} \\ M_o &= P_{ah} (HS/3) \\ &= 3632 \text{ lbs} (12.66'/3) \\ &= 15327 \text{ ft-lbs} \\ R_v &= W_f + W_1 + W_2 + P_{av} \\ &= 1200 + 9600 + 1277 + 1208 = 13285 \text{ lbs/ft} \\ e &= 9.0'/2 - (67555 - 15327) / 13285 \\ &= 0.57' \end{aligned}$$

Applied Bearing Pressure - Service 1 (*no load factor*)

Equation (3j)

$$\begin{aligned} \sigma_v &= R_v / (B - 2e) \\ &= 13285 / (9.0' - 2 \times 0.57') \\ &= 1690 \text{ lbs/sf} \end{aligned}$$

#### 11) Bearing Capacity

$$\text{Equation (3k)} \quad Q_{ult} = cN_c + \gamma DN_q + 0.5\gamma BN\gamma$$

where:

$$\begin{aligned} N_c &= 30.14, N_q = 18.4, N\gamma = 22.40 \\ B &= (B - 2e) = (9.0' - 2 \times 0.57') = 7.86' \\ D &= 2.0' \text{ level embedment} \\ c &= 0 \\ Q_{ult} &= 0 + (120)(2)(18.4) + (0.5)(120)(7.86)(22.40) \\ &= 14980 \text{ psf} \\ CDR_{br} &= RF_{br} (Q_{ult} / \sigma_v) \quad (\text{uses strength I } \sigma_v) \\ &= 0.65 (14980 / 2353) = \mathbf{4.14} > 1.0 \text{ OK} \end{aligned}$$



### 3H:1V SLOPING SURCHARGE AASHTO LRFD METHODOLOGY

**Internal Stability** - The internal analysis must look at the maximum loads at each grid level, connection strength, pullout resistance, and local stability concerns:

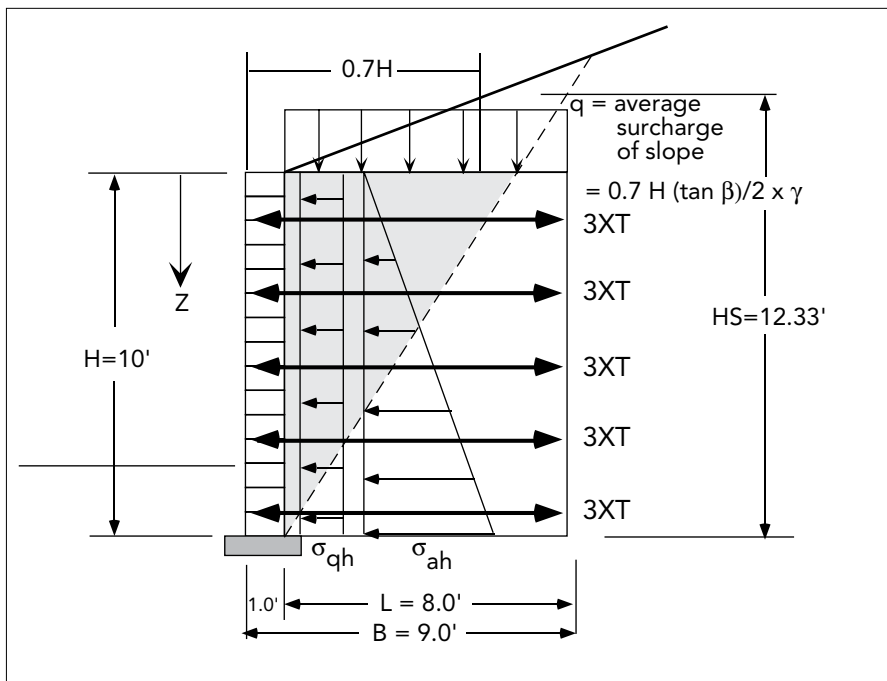

The internal earth pressure at any level is calculated as follows:

$$\begin{aligned} \sigma_{ah} &= E V_d \times \gamma Z k_a \\ &= 1.35 \times (120 \text{ pcf})(Z)(0.283) \\ &= 45.8 (Z) \text{ plf} \\ \sigma_{qh} &= E V_d \times q k_a \\ &= 1.35 \times 0.7 \times 10' \times \tan 18.4^\circ / 2 \times 120 \text{ pcf} (0.283) \\ &= 53.4 \text{ plf} \end{aligned}$$

The calculated pressure is applied to the tributary area of each reinforcement level which determines the tensile load in the geogrid reinforcement.

The AASHTO LRFD method calculates the internal active earth pressure coefficient based on a level backfill in accordance with the Rankine earth pressure formula and applies the slope as an average surcharge on a level backfill.



### 3H:1V SLOPING SURCHARGE AASHTO LRFD METHODOLOGY

#### 12) Maximum Grid Tension

The calculated grid tensions (plf) are tabulated below:

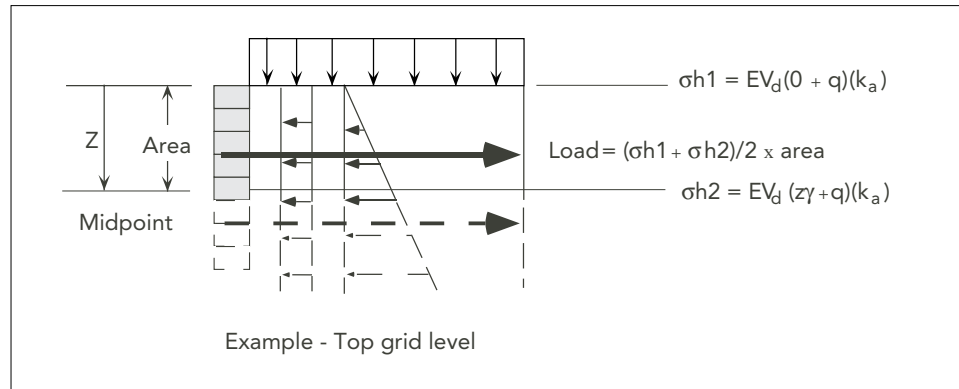

Mirafi 3XT has an allowable design capacity of 1717 plf (LRFD) from the first page which is greater than the calculated tension value at each level.

	GRID	DEPTH	z	$\sigma_{ah}$	$\sigma_{qh}$	$\sigma_{tot}$	Ave	Area	Load
		TOP	0.0	0.0	53.4	53.4			
5)	3XT	1.33'					107	2.33	249
		MID	2.33'	106.7	53.4	160.1			
4)	3XT	3.33'					206	2.00	412
		MID	4.33'	198.3	53.4	251.7			
3)	3XT	5.33'					298	2.00	596
		MID	6.33'	289.9	53.4	343.3			
2)	3XT	7.33'					389	2.00	778
		MID	8.33'	381.5	53.4	434.9			
1)	3XT	9.33'					473	1.67	790
		BOTTOM	10.00	458.0	53.4	511.4			

Therefore, Mirafi 3XT is OK for all five levels in tension.

The connection capacity, pullout calculations, and local stability are checked in a similar manner based on this load distribution. The "simplified" equivalent surcharge method distributes the loads differently and is weighted towards the upper wall section. A drawback of this method is that the calculated internal loads increase as the reinforcement lengths increase, which is not consistent with earth pressure theory.





### 3H:1V SLOPING SURCHARGE AASHTO LRFD METHODOLOGY

#### 13) Pullout Resistance

Pullout safety factors are determined on a level-by-level basis. The effective lengths and calculated pullout is determined at each level and compared to a capacity demand ratio of 1.0.

$$CDR_{po} = RF_{po} (\text{Pullout Resistance} / \text{Grid Tension})$$

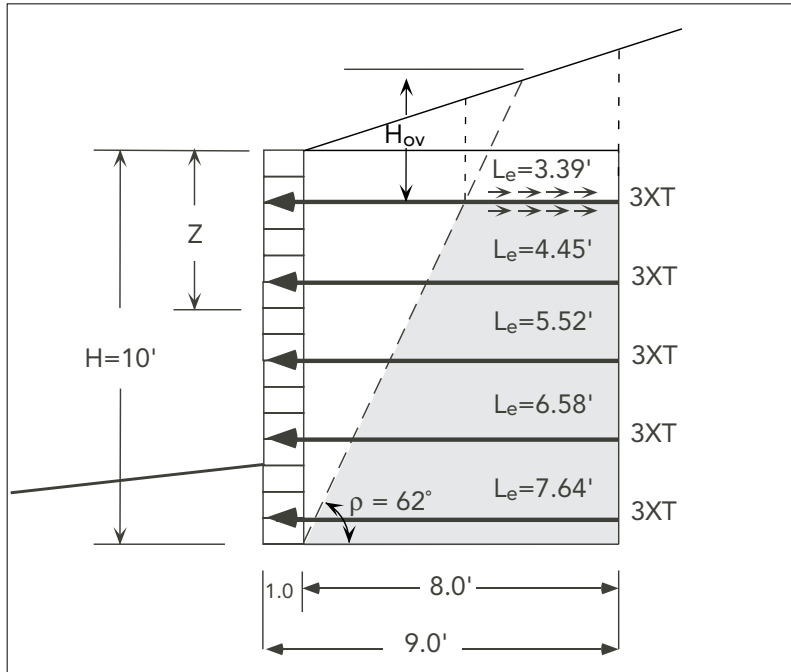

Check each grid level for available pullout resistance against previously calculated tensile loads.

Pullout Resistance =  $(\alpha EV_r)(\gamma H_{ov}) (2L_e) (\text{Tan}(\phi)C_i)$  with  $H_{ov}$  = average height of overburden and default scale effect correction factor  $\alpha = 0.80$ .

$$L_e = (L - \text{Height} / \text{Tan}\rho)$$

$$H_{ov} = z + [\text{Height} / \text{Tan}\rho + 0.5 L_e] \text{Tan}\beta$$

$$\alpha = 0.80$$

$$EV_r = 1.00$$

	Height	Grid	z	H <sub>ov</sub>	γ	L <sub>e</sub>	Tan34	C <sub>i</sub>	RF <sub>po</sub>	Pullout	Load	CDR <sub>po</sub>
5)	8.67'	3XT	1.33	3.43	120	3.39	.674	0.90	0.9	1354	249	4.90
4)	6.67'	3XT	3.33	5.25	120	4.45	.674	0.90	0.9	2721	412	5.94
3)	4.67'	3XT	5.33	7.07	120	5.52	.674	0.90	0.9	4546	596	6.86
2)	2.67'	3XT	7.33	8.90	120	6.58	.674	0.90	0.9	6821	778	7.89
1)	0.67'	3XT	9.33	10.71	120	7.64	.674	0.90	0.9	9530	790	10.86

OK - All capacity demand ratios are greater than 1.0.



### 3H:1V SLOPING SURCHARGE AASHTO LRFD METHODOLOGY

#### 14) Connection Strength

The last major item to check is the geogrid connection strength. KeyWallPRO incorporates the laboratory connection test data for all Keystone unit types connected to different geogrid types. The following chart is applicable for Keystone Compac II units and Mirafi 3XT geogrid in this example. The equations for these connection curves are:

**Two Stage Curve:**

$$\text{Connection} = cs1 + N \times S1 \text{ up to } N = IP-1$$

where:

$$S1 = (cs2 - cs1) / IP-1$$

$$N > IP-1 = cs2 + (N - IP-1) \times S2 < csMax$$

where:

$$S2 = (csMax - cs2) / (IP-2 - IP-1)$$

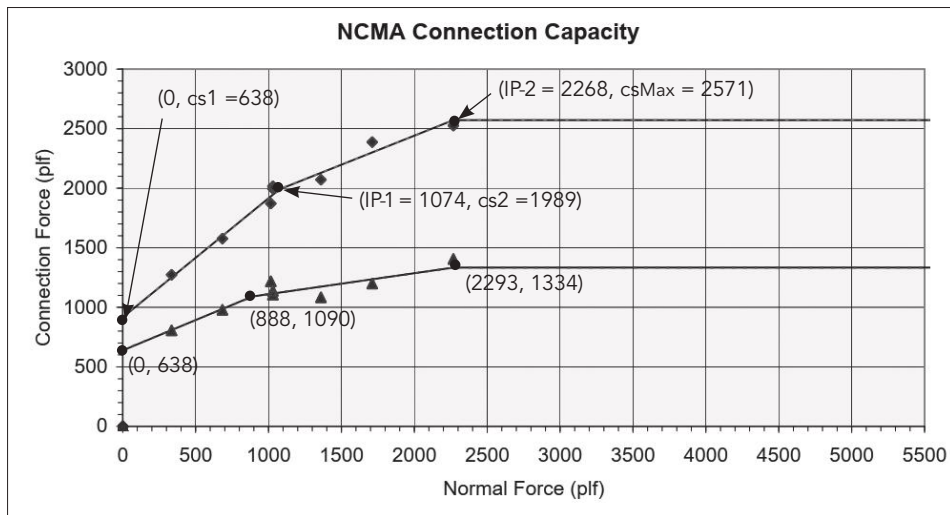

$$\text{Peak Connection} = 915 + N \times 1.0 \text{ up to } N = 1074 \text{ plf}$$

$$N > 1074 \text{ plf} = 1989 + (N - 1074) \times 0.488 < 2571 \text{ plf max}$$

	Height	Grid	Depth	N	$[\phi_{GEO} / (RF_{cn-d} \times RF_{cn-cr})] \times T_{peak}$	Conn. Resist.	Load			
5)	8.67'	3XT	1.33	160	0.90	1.15	1.15	1075	732	249
4)	6.67'	3XT	3.33	400	0.90	1.15	1.15	1315	895	412
3)	4.67'	3XT	5.33	640	0.90	1.15	1.15	1555	1058	596
2)	2.67'	3XT	7.33	880	0.90	1.15	1.15	1795	1222	778
1)	0.67'	3XT	9.33	1120	0.90	1.15	1.15	2011	1369	790

OK - Calculated loads are less than the maximum allowable for Peak and Serviceability connection criteria (AASHTO LRFD method does not check serviceability as the default setting).



## **3H:1V SLOPING SURCHARGE AASHTO LRFD METHODOLOGY**

### **15) Crest Toppling**

The KeyWallPRO program also checks the spacing between geogrid levels and the cantilever at the top of wall against the stability of the facing units. Keystone Compac II units are typically spaced no greater than 3 blocks between geogrid levels to remain stable during construction and eliminate concerns over local stability. The cantilever at the top of wall is also checked against the final loading condition as a small gravity wall. By inspection, the two-unit vertical cantilever is ok with the 3:1 sloping surcharge and the three-block maximum spacing between geogrids will be stable during construction and in the final design condition.

### **Summary**

The hand calculations verify the attached computer output. The data and methods conform to the AASHTO LRFD design methods as outlined in this manual.

The internal stresses are calculated using a level earth pressure coefficient and the sloping fill as an equivalent uniform surcharge.



**PART SIX**  
Appendix D

### 3H:1V SLOPING SURCHARGE AASHTO LRFD METHODOLOGY

Project: Keystone Design Manual - Appendix D [Rev. 1] NA

Wall: Soil Reinforced Wall, 3 to 1 Backslope, AASHTO LRFD

**Section** Soil Reinforced Wall, 3 to 1 Backslope, AASHTO LRFD  
**Report Date** November 18, 2019  
**Designer** JLG  
**Design Standard** AASHTO 2015 (LRFD)  
**Design** Static  
**Unit of Measure** U.S./Imperial  
**Selected Facing Unit** Product Line: Keystone Pinned Systems  
 Name: Compac II  
**Seismic As** N/A

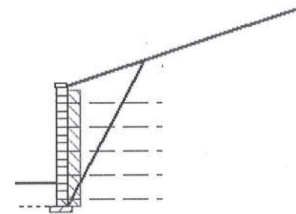

Soil Parameters	Phi Angle	Cohesion	Unit Weight	Description
Soil Zone	[degrees]	[lb/ft²]	[lb/ft³]	
Reinforced	34	n/a	120.00	
Retained	30	0.00	120.00	
Foundation	30	0.00	120.00	
Leveling Pad	40	n/a	n/a	
Drainage	38	n/a	0.70	

**Section Details**

Section Height	10.33	Back Slope	18.40°	LL Surcharge	0	DL Surcharge	0
Design Height	10.00 ft	Crest Offset	0.00 ft	LL Offset	0.00 ft	DL Offset	0.00 ft
Embedment	2.00 ft	Wall Batter	0.00°	Toe Slope	0.00°	Toe Offset	0.00 ft

**Reinforced Load and Resistance Factors - Static**

Term	Description	Minimum (as appl.)	Maximum (as appl.)
LFDC	Load - Dead Load (Structure)	0.90	1.25
LFES	Load - Earth Surcharge Load	0.75	1.50
LFEH	Load - Horz. Pressure of earth fill	0.90	1.50
LFCT	Load - Vehicular Collision Force	0.00	1.00
LFLL	Load - Vehicular Live Load	0.00	1.75
LFEV	Load - Vert. Pressure of earth fill	1.00	1.35
BEARING	Resistance - Bearing	0.65	0.00
TCONN	Resistance - Connection	0.90	0.00
PULLOUT	Resistance - Pullout	0.90	0.00
SLIDING	Resistance - Sliding	1.00	0.00
TAL	Resistance - Tensile	0.90	0.00

**Reinforcements**

**3XT - Miragrid 3XT Supplier: TenCate Mirafi - Miragrid XT HITEC, Fill Type: Sands**

Tult	3,500.00 lb/ft	RFcr	1.60	RFid	1.15	RFd	1.15
LTDS	1,654.06 lb/ft	Cds	0.90	Ci	0.90	α Correction	0.80

**Connection/Shear Properties**

acs1	915.00 lb/ft	IP-1	1,074.00 lb/ft	acs2	1,989.00 lb/ft	IP-2	2,268.00 lb/ft
acs max	2,571.35 lb/ft	au	1,250.00 lb/ft	au	29.00 lb/ft	Vu(max)	3,129.00 lb/ft
TLot Reduct.	1.00	cn RFcr	1.15	cn RFd	1.15		

**Analysis Results**

- \* Embedment is included in Bearing Capacity
- \* Analysis uses Vertical Earth Pressure Factor, EV, for internal tension

External Static	CDR		
Bearing Capacity	4.09	Bearing Pressure - Strength	2350.12 lb/ft²
Overturning	3.17	Bearing Pressure - Service	1689.96 lb/ft²
Base Sliding	1.47	Eccentricity for Overturning	0.90 ft
Crest Toppling	3.77	Max Eccentricity	2.25 ft
Internal Sliding	2.00		

Internal Static					Tensile Resist.	Tensile CDR	Pullout Resist.	Pullout CDR	Conn. Resist.	Conn. CDR
Layer	Elevation	Rein	Length	Load						
5	8.67	3XT	9.00	249	1,489	5.98	1,221	4.90	732	2.94
4	6.67	3XT	9.00	412	1,489	3.61	2,455	5.96	895	2.17
3	4.67	3XT	9.00	595	1,489	2.50	4,097	6.88	1,058	1.78
2	2.67	3XT	9.00	778	1,489	1.91	6,145	7.89	1,222	1.57
1	0.67	3XT	9.00	789	1,489	1.89	8,600	10.91	1,369	1.74

# PART SIX



## APPENDIX E

*The Falls Event Center, Littleton, Colorado; Regal Stone Pro RockFace 3-pc*

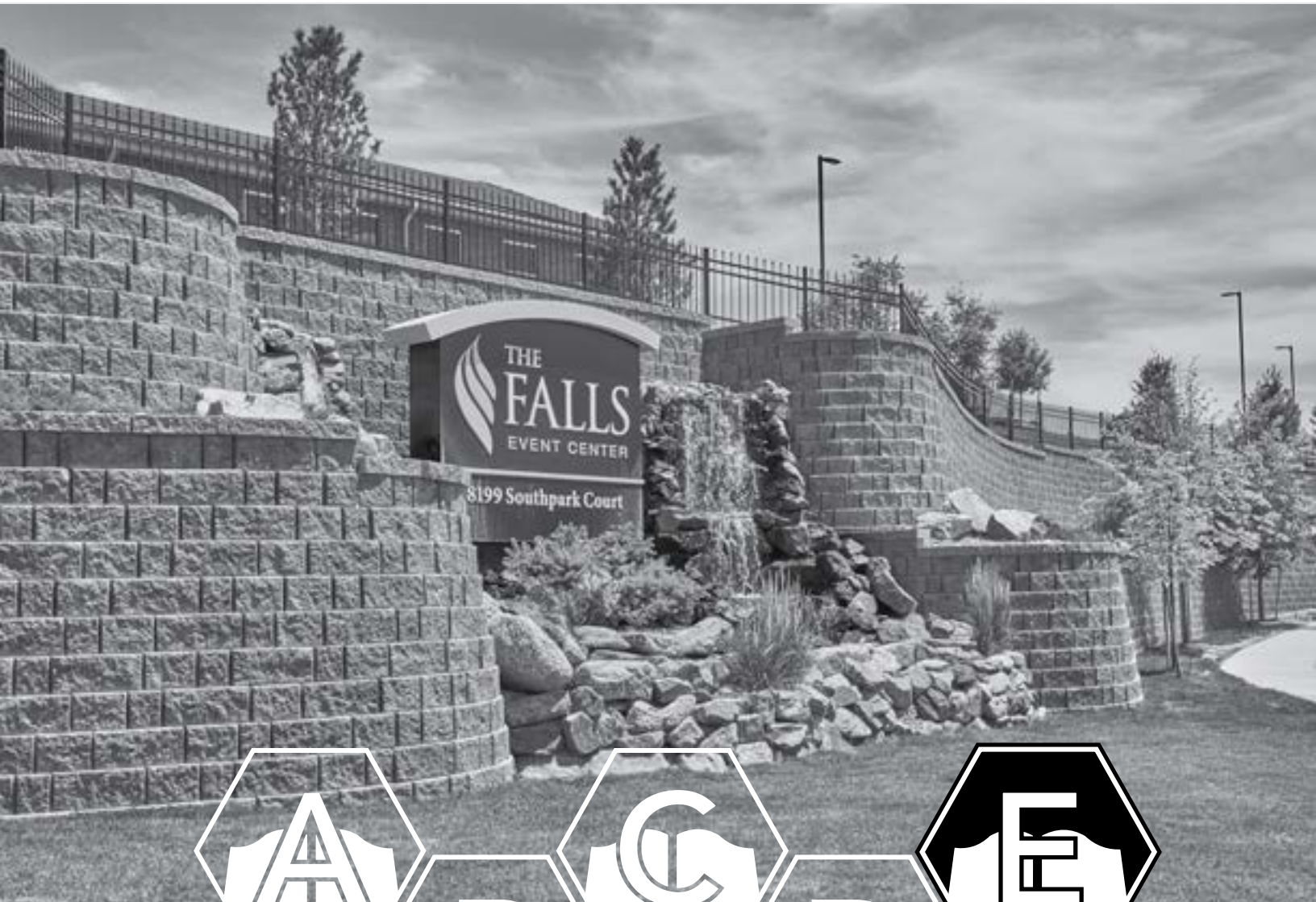



## AASHTO LRFD METHODOLOGY LEVEL SURCHARGE - 250 PSF

This set of calculations is intended to verify the KeyWallPRO program output of a typical reinforced soil wall design section. The design follows the AASHTO LRFD procedure outlined previously in the Keystone Design Manual. The pertinent design information is summarized below:

### 1) General Design Data

Keystone Compac III Units (120 pcf with drainage fill and  $W_u = 1.00'$ )

Mirafi 3XT Polyester Geogrid

Wall Batter(t) =  $0^\circ$ , near-vertical orientation

Design Height = 10' (8' exposed + 2' embedment)

Base Length, B = 9' (uniform lengths chosen for simplicity)

Backslope,  $\beta = 0$ , level backslope

Surcharge = 250 psf (typical roadway surcharge)

### 2) Soil Parameters (*degrees, psf, pcf*)

SOIL PARAMETERS	$\phi$	c	$\gamma$
Reinforced Soil	34	0	120
Retained Soil	30	0	120
Foundation Soil	30	0	120

### 3) Geogrid Design Parameters (*plf*)

Geogrid	$T_{ult}$	$RF_{cr}$	$RF_d$	$RF_{id}$	LTDS	$\phi_{GEO}$	$T_{al}$
Mirafi 3XT	3500	1.45	1.15	1.10	1908	0.90	<b>1717plf</b>

$C_i$  &  $C_d$ s = 0.90 for select backfill

$RF_{cn-d} = 1.15$

$RF_{cn-cr} = 1.20$

### 4) Load and Resistance Factors - Strength I

Driving Load Factors	Resisting Load Factors
$EH_d = 1.50$	$EH_r = 0.90$
$EV_d = 1.35$	$EV_r = 1.00$
$ES_d = 1.50$	$ES_r = 0.75$
$LL_d = 1.75$	

AASHTO LRFD Load Factors

Resistance Factors
Sliding $RF_{sl} = 1.00$
Bearing $RF_b = 0.65$
Tension $RF_t = 0.90$
Pullout $RF_{po} = 0.90$

AASHTO LRFD Resistance Factors



## AASHTO LRFD METHODOLOGY LEVEL SURCHARGE - 250 PSF

### 5) Geometric Parameters - AASHTO LRFD

Internal	External
$\phi = 34$ degrees	$\phi = 30$ degrees
$\delta = \beta = 0$ degrees (no backslope)	$\delta = \beta = 0$ degrees (no backslope)
$\alpha = 90$ degrees (90° + no batter)	$\alpha = 90$ degrees (90° + no batter)
$\beta = 0$ degrees (level)	$\beta = 0$ degrees (level)

### 6) Rankine Earth Pressure Calculation

#### Internal

##### Equation (3g)

$$k_a = \tan^2(45 - \phi/2)$$
$$k_a = 0.283 \text{ for above parameters - Rankine}$$

##### Equation (3h)

$$\rho = 45 + \phi/2$$
$$\rho = 62.0^\circ \text{ for above parameters - Rankine}$$

#### External

##### Equation (3g)

$$k_a = \tan^2(45 - \phi/2)$$
$$k_a = 0.333 \text{ for above parameters - Rankine}$$

#### External Forces

##### Equation. (3e)

$$P_a = \frac{1}{2} \gamma H^2 k_a$$
$$P_{ah} = \frac{1}{2} \gamma H^2 k_a \cos(\beta) - \text{Horizontal Component}$$
$$P_{ah} = (0.5)(120 \text{ pcf})(10')^2 (0.333) \cos(0)$$
$$P_{ah} = 2000 \text{ lbs/lf}$$

##### Equation. (3f)

$$P_q = q H k_a$$
$$P_{qh} = q H k_a \cos(\beta) - \text{Horizontal Component}$$
$$P_{qh} = (250 \text{ psf})(10')(0.333) \cos(0)$$
$$P_{qh} = 833 \text{ lbs/lf}$$

#### External Masses

$$W_f = W_u H \gamma = (1.00')(10')(120 \text{ pcf}) = 1200 \text{ lbs/lf}$$
$$W_1 = (B - W_u) H \gamma = (9' - 1.0')(10')(120 \text{ pcf}) = 9600 \text{ lbs/lf}$$
$$W_q = q (B - W_u) = (250 \text{ psf})(9' - 1.0') = 2000 \text{ lbs/lf}$$



## AASHTO LRFD METHODOLOGY LEVEL SURCHARGE - 250 PSF

### External Stability Diagram

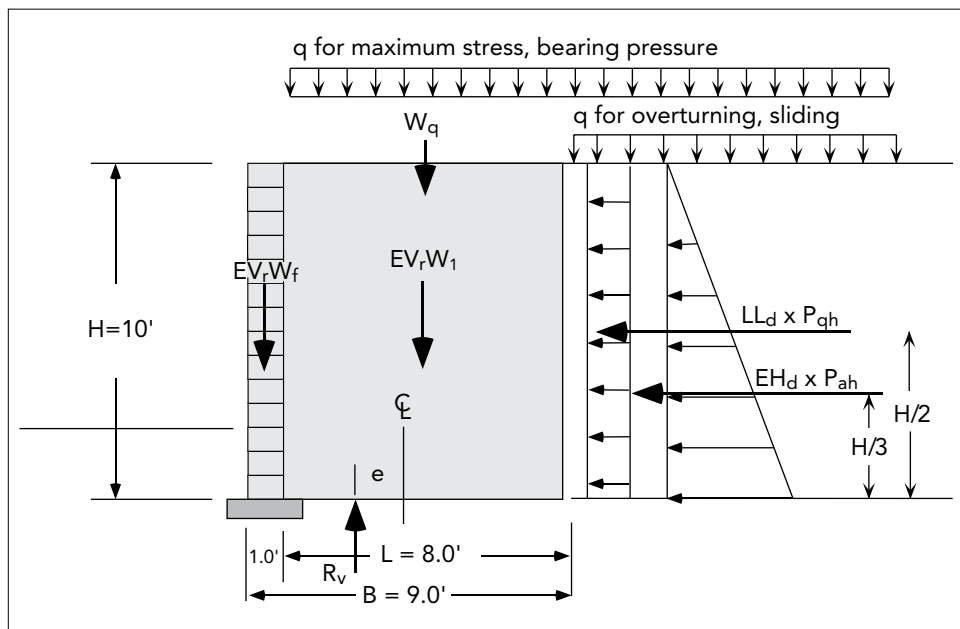

### 7) Overturning

#### Overturning Moment

$$\begin{aligned}
 M_o &= E H_d \times P_{ah} (H/3) + LL_d \times P_{qh} (H/2) \\
 &= 1.50 \times 2000 \text{ lbs} (10'/3) + 1.75 \times 833 \text{ lbs} (10'/2) \\
 &= \mathbf{17289 \text{ ft-lbs}}
 \end{aligned}$$

#### Resisting Moment *(live load $W_q$ does not contribute to resisting moment)*

$$\begin{aligned}
 M_r &= E V_r \times W_f (W_u/2) + E V_r \times W_1 (W_u + L/2) \\
 &= 1.00 \times 1200 (1.00' / 2) + 1.00 \times 9600 (1.0' + 8.0' / 2) \\
 &= \mathbf{48600 \text{ ft-lbs}}
 \end{aligned}$$

$$CDR_{ot} = M_r / M_o = 48600 / 17289 = \mathbf{2.81 > 1.0 \text{ OK}}$$





## AASHTO LRFD METHODOLOGY LEVEL SURCHARGE - 250 PSF

### 8) Base Sliding

#### Lateral Driving Forces

$$\begin{aligned} R_d &= E H_d \times P_{ah} + L L_d \times P_{qh} \\ &= 1.50 \times 2000 \text{ lbs} + 1.75 \times 833 \text{ lbs} \\ &= 4458 \text{ lbs/ft} \end{aligned}$$

#### Lateral Resisting Forces

$$\begin{aligned} R_r &= E V_r (W_f + W_1) \times \tan \phi \text{ of foundation} \\ &= 1.00(1200 + 9600) \times 0.577 \\ &= 6232 \text{ lbs/ft} \\ CDR_{sl} &= R_{fsl} (R_r/R_d) = 1.00(6232/4458) = 1.40 > 1.0 \text{ OK} \end{aligned}$$

### 9) Sliding at Lowest Reinforcement Level

#### Lateral Driving Forces (at depth of 9.33')

$$\begin{aligned} R_d &= E H_d \times P_{ah} + L L_d \times P_{qh} \\ &= 1.50 \times 1739 \text{ lbs} + 1.75 \times 777 \text{ lbs} \\ &= 3968 \text{ lbs/ft} \end{aligned}$$

#### Lateral Resisting Forces (at depth of 9.33')

$$\begin{aligned} \tau_{unit} &= a_u + N \tan \lambda_u < V_{u(max)} = 2762 \text{ lbs/ft} \\ \tau_{unit} &= E V_r [900 + N \tan (34^\circ)] \\ &= 1.00 [900 \text{ plf} + (9.33' \times 1.00' \times 120 \text{ pcf}) \tan (34^\circ)] \\ &= 1655 \text{ plf} \\ \tau_{soil} &= E V_r (\gamma H (B - W_u)) \times \tan \phi \text{ (of reinforced material)} \times C_{ds} \\ &= 1.00 (120 \text{ pcf} \times 9.33' \times 8') \times 0.675 \times 0.90 \\ &= 5441 \text{ lbs/ft} \\ CDR_{sl} &= R_{fsl} (R_r/R_d) = 1.00 [(1655+5441)/3968] = 1.79 > 1.0 \text{ OK} \end{aligned}$$

### 10) Bearing Pressure ( $M_r$ and $R_v$ do not use live load, $M_o$ uses live load, driving load factors used for min e)

#### Eccentricity - Strength 1

##### Equation (3i)

$$\begin{aligned} e &= B/2 - (M_r - M_o) / R_v \\ M_r &= E V_d \times W_f (W_u / 2) + E V_d \times W_1 (W_u + L/2) \\ &= 1.35 \times 1200 (1.00'/2) + 1.35 \times 9600 (1.0' + 8.0'/2) \\ &= 65610 \text{ ft-lbs} \\ M_o &= 17289 \text{ ft-lbs (from overturning calculation)} \\ R_v &= E V_d (W_f + W_1) \\ &= 1.35(1200 + 9600) = 14580 \text{ lbs/ft} \\ e &= 9.0'/2 - (65610 - 17289) / 14580 \\ &= 1.19' \end{aligned}$$



## AASHTO LRFD METHODOLOGY LEVEL SURCHARGE - 250 PSF

**Max. Applied Bearing Pressure - Strength 1** (*R<sub>v</sub> uses live load and driving load factors*)

**Equation (3j)**

$$\begin{aligned}\sigma_v &= R_v / (L-2e) \\ R_v &= EV_d (W_f + W_1) + LL_d \times W_q \\ &= 1.35(1200 + 9600) + 1.75 \times 2000 = 18080 \text{ lbs/ft} \\ \sigma_v &= 18080 / (9.0' - 2 \times 1.19') \\ &= 2731 \text{ psf}\end{aligned}$$

**Eccentricity - Strength 1** (*from overturning calculation, R<sub>v</sub> does not use live load, R<sub>v</sub> uses resisting load factors*)

**Equation (3i)**

$$\begin{aligned}e &= B/2 - (M_r - M_o) / R_v \\ M_r &= 48600 \text{ ft-lbs (from overturning calculation)} \\ M_o &= 17289 \text{ ft-lbs (from overturning calculation)} \\ R_v &= EV_r \times (W_f + W_1) \\ &= 1.00 \times (1200 + 9600) = 10800 \text{ lbs/ft} \\ e &= 9.0'/2 - (48600 - 17289) / 10800 \\ &= 1.60' < B/4 = 9.0'/4 = 2.25' \text{ Ok}\end{aligned}$$

**Eccentricity - Service 1** (*M<sub>r</sub> and R<sub>v</sub> do not use live load, M<sub>o</sub> uses live load, no load factors*)

**Equation (3i)**

$$\begin{aligned}e &= B/2 - (M_r - M_o) / R_v \\ M_r &= W_f (W_u/2) + W_1 (W_u + L/2) \\ &= 1200 (1.00'/2) + 9600 (1.0' + 8.0'/2) \\ &= 48600 \text{ ft-lbs} \\ M_o &= P_{ah} (H/3) + P_{ah} (H/2) \\ &= 2000 (10'/3) + 833 (10'/2) \\ &= 10832 \text{ ft-lbs} \\ R_v &= W_f + W_1 \\ &= 1200 + 9600 = 10800 \text{ lbs/ft} \\ e &= 9.0'/2 - (48600 - 10832) / 10800 \\ &= 1.00'\end{aligned}$$

**Applied Bearing Pressure - Service 1** (*R<sub>v</sub> uses live load, no load factors*)

**Equation (3j)**

$$\begin{aligned}\sigma_v &= R_v / (L-2e) \\ R_v &= W_f + W_1 + W_q \\ R_v &= 1200 + 9600 + 2000 = 12800 \\ \sigma_v &= 12800 / (9.0' - 2 \times 1.00') \\ &= 1829 \text{ lbs/sf}\end{aligned}$$

**Note:**

*The external analysis is limited to simple overturning, sliding, applied bearing pressure and bearing capacity for the reinforced mass based on a level toe. No attempt has been made to evaluate the more complicated geotechnical concerns of settlement and global stability. Geotechnical site and soils evaluation is a site-specific art and cannot be programmed.*



## AASHTO LRFD METHODOLOGY LEVEL SURCHARGE - 250 PSF

### 11) Bearing Capacity

Equation (3k)

$$Q_{ult} = cN_c + \gamma DN_q + 0.5\gamma (B-2) N_\gamma$$

where:

$$N_c = 30.14, N_q = 18.4, N_\gamma = 22.40$$

$$B = (B-2e) = (9.0' - 2 \times 1.19') = 6.62'$$

$$D = 2.0' \text{ level embedment}$$

$$c = 0$$

$$Q_{ult} = 0 + (120)(2)(18.4) + (0.5)(120)(6.62)(22.40)$$

$$= 13313 \text{ psf}$$

$$CDR_{br} = RF_{br} (Q_{ult}/\sigma_v)$$

$$CDR_{dr} = 0.65 (13313/2731) = 3.17 > 1.0 \text{ OK}$$

**Note:**

*Eccentricity and max bearing pressure from Strength 1 calculation used.*

**Internal Stability** - The internal analysis must look at the maximum loads at each grid level, connection strength, pullout resistance, and local stability concerns:

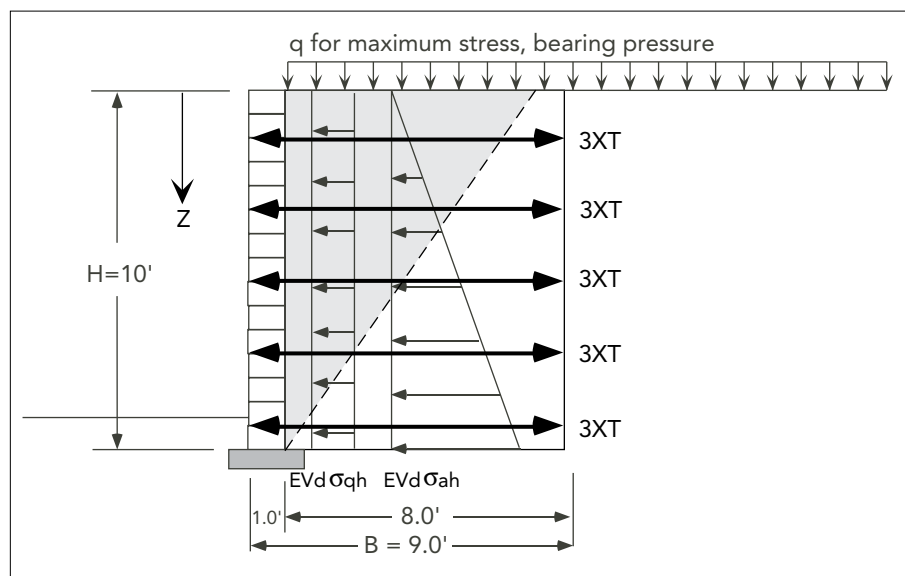

**Note:**

*AASHTO LRFD uses vertical earth pressure load factor  $EV_d$  for the live load surcharge versus using  $LL_d$ .*

The internal earth pressure at any level is calculated as follows:

$$\begin{aligned} \sigma_{ah} &= EV_d \gamma Z k_a \cos(\beta) \\ &= 1.35 \times (120 \text{ pcf}) (Z) (0.283) \cos(0) \\ &= 45.8 (Z) \text{ plf} \end{aligned}$$

$$\begin{aligned} \sigma_{qh} &= EV_d q k_a \cos(\beta) \\ &= 1.35 \times (250 \text{ psf}) (0.283) \cos(0) \\ &= 95.5 \text{ plf} \end{aligned}$$

The calculated pressure is applied to the tributary area of each reinforcement level which determines the tensile load in the geogrid reinforcement.



**AASHTO LRFD METHODOLOGY LEVEL SURCHARGE - 250 PSF**

12) Maximum Grid Tension

The calculated grid tensions (plf) are tabulated below:

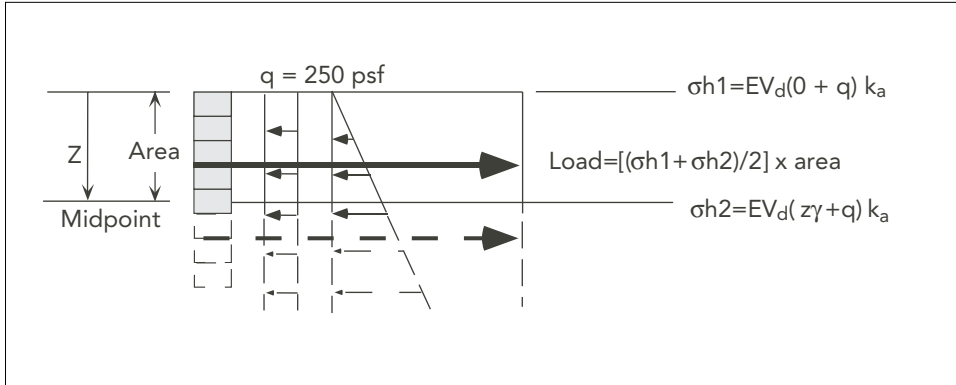

	GRID	DEPTH	z	$\sigma_{ah}$	$\sigma_{qh}$	$\sigma_{tot}$	Ave	Area	Load
		TOP	0.0	0.0	95.5	95.5			
5)	3XT	1.33'					149	2.33	347
		MID	2.33'	106.7	95.5	202.2			
4)	3XT	3.33'					248	2.00	496
		MID	4.33'	198.3	95.5	293.8			
3)	3XT	5.33'					340	2.00	680
		MID	6.33'	289.9	95.5	385.4			
2)	3XT	7.33'					431	2.00	862
		MID	8.33'	381.5	95.5	477.0			
1)	3XT	9.33'					515	1.67	860
		BOTTOM	10.00	458.0	95.5	553.5			

Mirafi 3XT has an allowable design capacity of 1717 plf from the first page which is greater than the calculated value at each level. Therefore, Mirafi 3XT is OK for all five levels in tension.



## AASHTO LRFD METHODOLOGY LEVEL SURCHARGE - 250 PSF

### 13) Pullout Resistance

Pullout safety factors are determined on a level-by-level basis. The effective lengths and calculated pullout is determined at each level and compared to a capacity demand ratio of 1.0.

$$CDR_{po} = RF_{po} (\text{Pullout Resistance} / \text{Grid Tension})$$

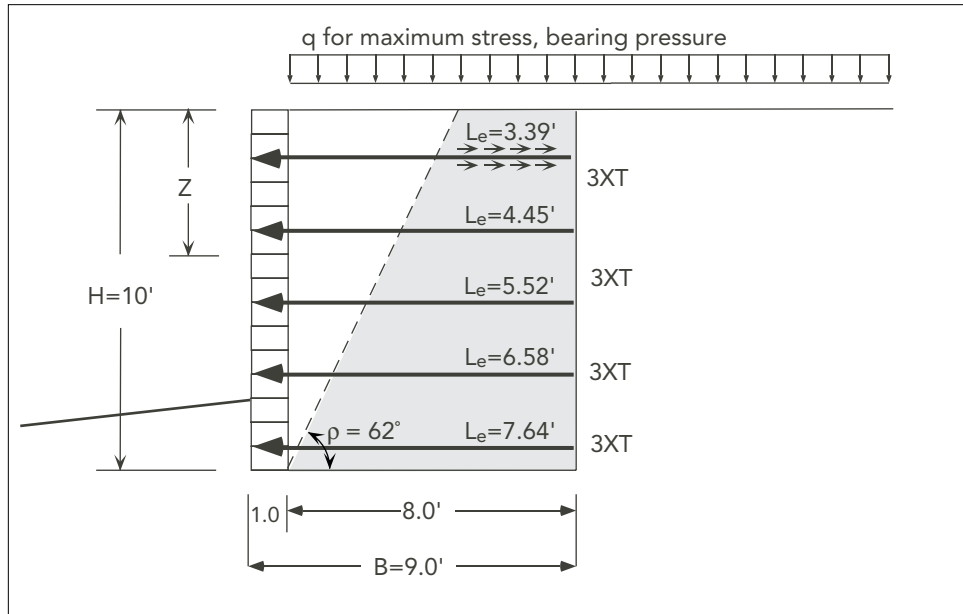

Check each grid level for available pullout resistance against previously calculated tensile loads. A live load surcharge is not considered as a resisting force:

**Pullout Resistance** =  $(\alpha EV_r)(\gamma H_{ov}) (2L_e) (\text{Tan}(\phi)C_i)$  with  $H_{ov}$  = average height of overburden and default scale effect correction factor  $\alpha = 0.80$

$$L_e = (L - \text{Height} / \text{Tan } \rho)$$

$$\alpha = 0.80, EV_r = 1.00$$

	Height	Grid	Hov	$\gamma$	$L_e$	Tan34	$C_i$	$RF_{po}$	Pullout/Load	$CDR_{po}$
5)	8.67'	3XT	1.33	120	3.39	.674	0.90	0.90	525 347	1.36
4)	6.67'	3XT	3.33	120	4.45	.674	0.90	0.90	1726 496	3.13
3)	4.67'	3XT	5.33	120	5.52	.674	0.90	0.90	3407 680	4.51
2)	2.67'	3XT	7.33	120	6.58	.674	0.90	0.90	5617 862	5.86
1)	0.67'	3XT	9.33	120	7.64	.674	0.90	0.90	8302 860	8.69

OK - All capacity demands ratios are greater than 1.0



## AASHTO LRFD METHODOLOGY LEVEL SURCHARGE - 250 PSF

### 14) Connection Strength

The last major item to check is the geogrid connection strength. KeyWallPRO incorporates the laboratory connection test data for all Keystone unit types connected to different geogrid types. The following chart is applicable for Keystone Compac III units and Mirafi 3XT geogrid in this example:

#### Two Stage Curve:

$$\text{Connection} = cs1 + N \times S1 \text{ up to } N = IP-1$$

where:

$$S1 = (cs2 - cs1) / IP-1$$

$$N > IP-1 = cs2 + (N - IP-1) \times S2 < csMax$$

where:

$$S2 = (csMax - cs2) / (IP-2 - IP-1)$$

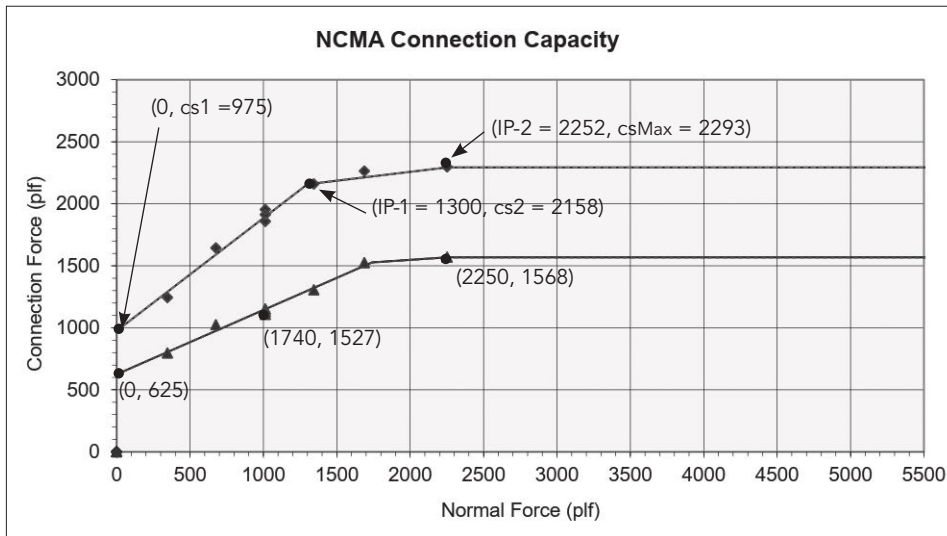

$$\text{Peak Connection} = 975 + 0.91 \times N \text{ up to } N = 1300 \text{ plf}$$

$$N > 1300 \text{ plf} = 2158 + (N - 1300) \times 0.142 < 2293 \text{ plf max}$$

	Height	Grid	Depth	N	$[\phi_{GEO} / (RF_{cn-d} \times RF_{cn-cr})] \times T_{peak} = T_{cl}$	Load
5)	8.67'	3XT	1.33'	160	0.90 1.15 1.20 1121 731	347
4)	6.67'	3XT	3.33'	400	0.90 1.15 1.20 1339 873	496
3)	4.67'	3XT	5.33'	640	0.90 1.15 1.20 1557 1015	680
2)	2.67'	3XT	7.33'	880	0.90 1.15 1.20 1776 1158	862
1)	0.67'	3XT	9.33'	1120	0.90 1.15 1.20 1994 1300	860

OK - Calculated loads are less than the maximum allowable for Peak connection criteria.

(AASHTO LRFD method does not check serviceability as the default setting)



## **AASHTO LRFD METHODOLOGY LEVEL SURCHARGE - 250 PSF**

### 15) Crest Toppling

The KeyWallPRO program also checks the spacing between geogrid levels and the cantilever at the top of wall against the stability of the facing units. Keystone Compac III units are typically spaced no greater than 3 blocks between geogrid levels to remain stable during construction and eliminate concerns over local stability. The cantilever at the top of wall is also checked against the final loading condition as a small gravity wall. By inspection, the two-unit vertical cantilever is ok with the 250 psf surcharge and the three-block maximum spacing between geogrids will be stable during construction and in the final design condition.

#### **Summary**

The hand calculations verify the attached computer output. The data and methods conform to the AASHTO LRFD design method as outlined in the Keystone Design Manual.



## AASHTO LRFD METHODOLOGY LEVEL SURCHARGE - 250 PSF

Project: Keystone Design Manual - Appendix E [Rev. 1] NA

Wall: Soil Reinforced Wall, Level Surcharge, AASHTO LRFD

**Section** Soil Reinforced Wall, Level Surcharge, AASHTO LRFD  
**Report Date** November 18, 2019  
**Designer** JLG  
**Design Standard** AASHTO 2015 (LRFD)  
**Design** Static  
**Unit of Measure** U.S./Imperial  
**Selected Facing Unit** Product Line: Keystone Pinned Systems  
 Name: Compac III  
**Seismic As** N/A

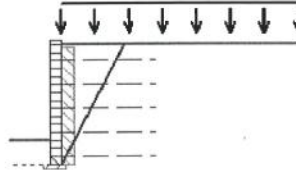

Soil Parameters	Phi Angle	Cohesion	Unit Weight	Description
Soil Zone	[degrees]	[lb/ft <sup>2</sup> ]	[lb/ft <sup>3</sup> ]	
Reinforced	34	n/a	120.00	
Retained	30	0.00	120.00	
Foundation	30	0.00	120.00	
Leveling Pad	40	n/a	n/a	
Drainage	38	n/a	0.70	

**Section Details**

Section Height	10.33	Back Slope	0.00°	LL Surcharge	250	DL Surcharge	0
Design Height	10.00 ft	Crest Offset	0.00 ft	LL Offset	0.00 ft	DL Offset	0.00 ft
Embedment	2.00 ft	Wall Batter	0.00°	Toe Slope	0.00°	Toe Offset	0.00 ft

**Reinforced Load and Resistance Factors - Static**

Term	Description	Minimum (as appl.)	Maximum (as appl.)
LFDC	Load - Dead Load (Structure)	0.90	1.25
LFES	Load - Earth Surcharge Load	0.75	1.50
LFEH	Load - Horz. Pressure of earth fill	0.90	1.50
LFCT	Load - Vehicular Collision Force	0.00	1.00
LFLL	Load - Vehicular Live Load	0.00	1.75
LFEV	Load - Vert. Pressure of earth fill	1.00	1.35
BEARING	Resistance - Bearing	0.65	0.00
TCONN	Resistance - Connection	0.90	0.00
PULLOUT	Resistance - Pullout	0.90	0.00
SLIDING	Resistance - Sliding	1.00	0.00
TAL	Resistance - Tensile	0.90	0.00

**Reinforcements**

3XT - Miragrid 3XT      Supplier: TenCate Mirafi - Miragrid XT, Fill Type: Sands

Tult	3,500.00 lb/ft	RFcr	1.45	RFd	1.10	RFd	1.15
LTDS	1,908.14 lb/ft	Cds	0.90	Ci	0.90	α Correction	0.80

**Connection/Shear Properties**

acs1	975.00 lb/ft	IP-1	1,300.00 lb/ft	acs2	2,157.91 lb/ft	IP-2	2,252.00 lb/ft
acs max	2,293.40 lb/ft	au	900.00 lb/ft	lu	34.00 lb/ft	Vu(max)	2,762.00 lb/ft
TLot Reduct.	1.00	cn RFcr	1.20	cn RFd	1.15		

**Analysis Results**

- \* Embedment is included in Bearing Capacity
- \* Analysis uses Vertical Earth Pressure Factor, EV, for internal tension

External Static	CDR		
Bearing Capacity	3.18	Bearing Pressure - Strength	2727.82 lb/ft <sup>2</sup>
Overturning	2.81	Bearing Pressure - Service	1830.19 lb/ft <sup>2</sup>
Base Sliding	1.40	Eccentricity for Overturning	1.60 ft
Crest Toppling	0.55	Max Eccentricity	2.25 ft
Internal Sliding	2.07		

Internal Static										
Layer	Elevation	Rein	Length	Load	Tensile Resist.	Tensile CDR	Pullout Resist.	Pullout CDR	Conn. Resist.	Conn. CDR
5	8.67	3XT	9.00	347	1,717	4.94	474	1.37	731	2.10
4	6.67	3XT	9.00	496	1,717	3.46	1,558	3.14	873	1.76
3	4.67	3XT	9.00	679	1,717	2.53	3,088	4.54	1,016	1.50
2	2.67	3XT	9.00	863	1,717	1.99	5,063	5.87	1,158	1.34
1	0.67	3XT	9.00	859	1,717	2.00	7,485	8.72	1,301	1.51





Distributed By:

We reserve the right to improve our products and make changes in the specifications and design without notice. The information contained herein has been compiled by KEYSTONE and to the best of our knowledge, accurately represents the KEYSTONE product use in the applications which are illustrated. Final determination of the suitability for the use contemplated and its manner of use are the sole responsibility of the user.



Keystone Retaining Wall Systems LLC  
4444 West 78th Street • Minneapolis, MN 55435  
(952) 897-1040 • [www.kestonewalls.com](http://www.kestonewalls.com)