

SECTION E

COMMON WALL CONSTRUCTION DETAILS

Since its inception in 1986, Keystone has been the segmental retaining wall design leader. This section covers a variety of the most common wall application details that may be confronted when constructing a Keystone wall. Some of the wall application details presented in this section have been developed specifically based on industry design standards. Other wall application details have been developed through our years of experience in the segmental retaining wall industry.

Items that are covered in this section:

- Water applications
- Utilities
- Retaining wall drainage
- Storm drain outlet
- Barriers
- Terraced wall applications
- Tree planting guidelines

Water Applications

When considering a water application for the Keystone wall system, the following areas need to be analyzed and designed to maintain structural integrity of the wall under normal, high-water conditions, and rapid draw-down conditions:

- Start by analyzing the wall under normal design criteria (i.e. wall height, base conditions, surcharge loads, soils data, reinforcement requirements, drainage, etc.)
- Determine the water level on the wall under normal and high-water conditions.
- Determine flow rate for streams, channels, etc.
- Determine degree of wave action: minor, major or boat wake.
- Determine the potential for flooding and inundation of the wall.
- The above conditions should be taken into account in the design of the wall.

Always contact a professional engineer to assist you in your water application design. At minimum, the wall reinforced zone soils, to 1 foot above the high-water elevation, should be a free-draining sand or gravel, wrapped in an appropriate filter fabric (see *Figure E:1, below*).

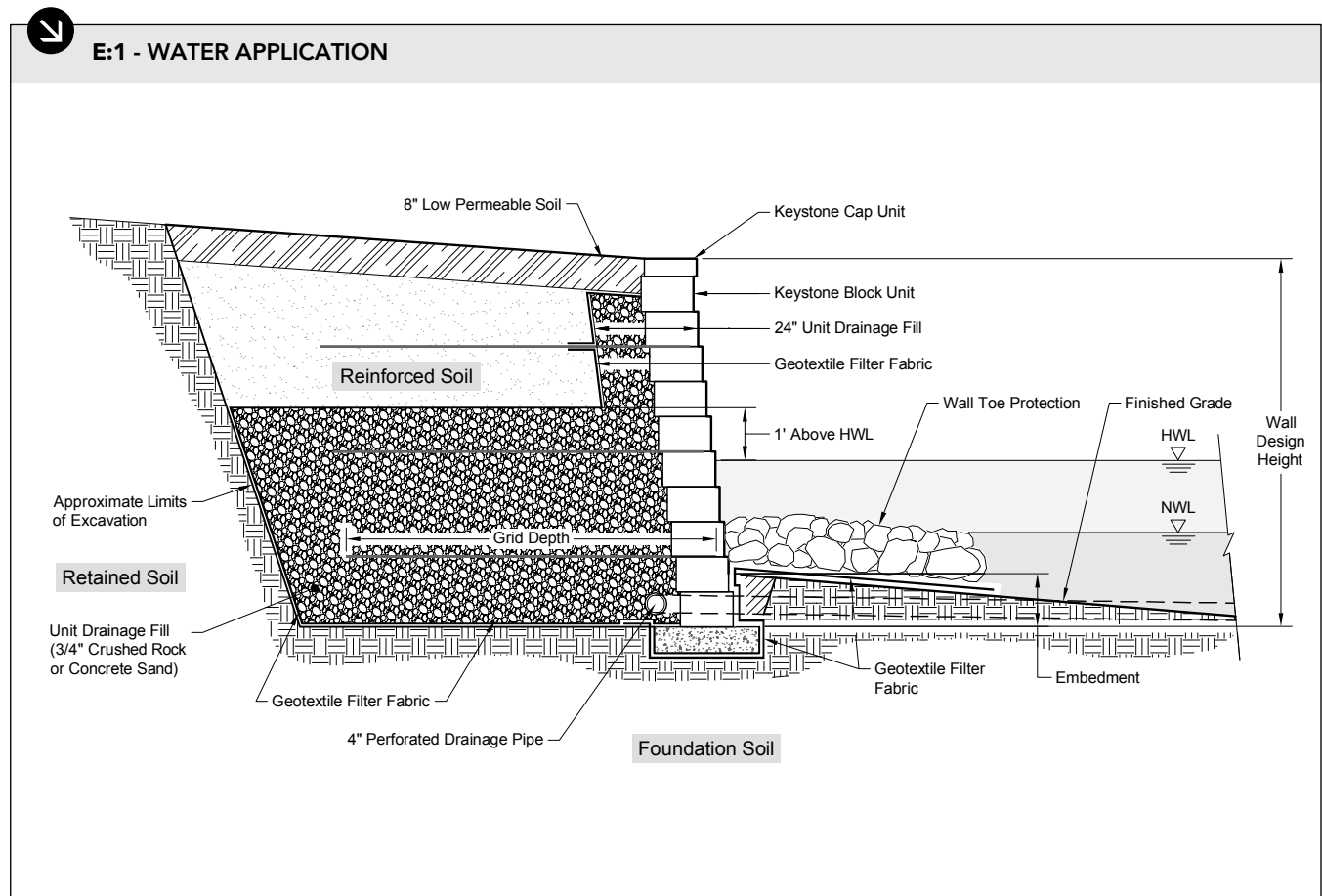

NOTE:

- Drains should be at the bottom of walls when possible. Utilize a raised drain location when bottom of wall drainage is not possible (see page 51).

Utilities

In general, the placement of utilities parallel to the wall, within the reinforced soil zone, **SHOULD BE AVOIDED**. Any maintenance to utilities in the reinforced soil zone will require deconstruction of the wall down to the pipe elevation so fully intact geogrid can be re-installed during backfilling. Also, coordination of the utility and wall contractors will be necessary during initial construction of the wall to avoid excavation through the geogrid.

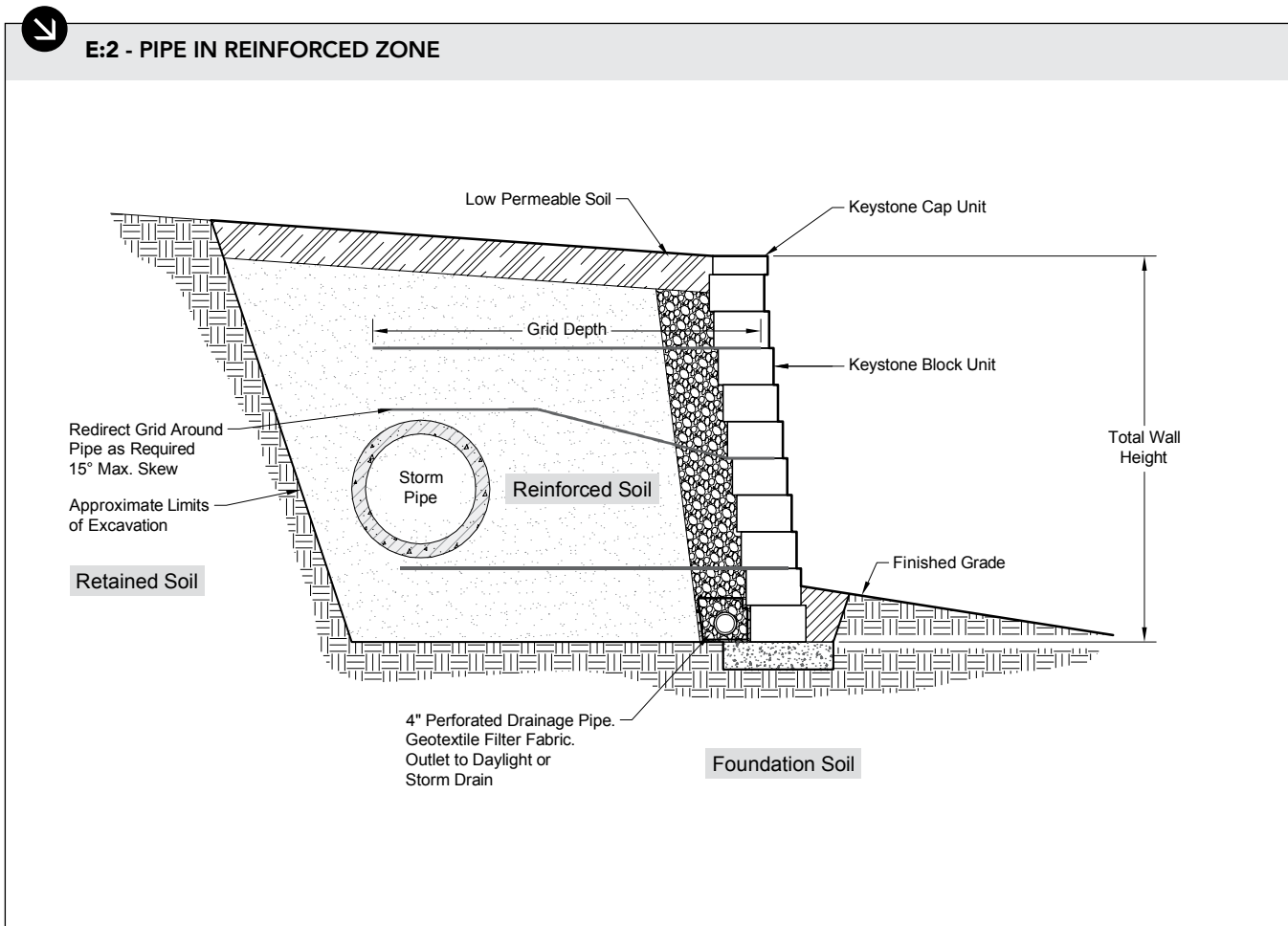

NOTE:

- Drain should be at bottom of wall when possible. Utilize raised drain location when bottom of wall drainage is not possible (see page 51).

Retaining Wall Drainage Options

Poor drainage is a leading cause of retaining wall performance issues. Hydrostatic pressure can accumulate behind a wall and add an increased load on the wall if drainage provisions are not installed or not adequate for the conditions. The Keystone system has superior drainage features. The techniques below should be considered where the project drainage issues are present.

- 1. Basic drainage/unit drainage fill:** Keystone's mortarless, interlocking system, with specific free-draining gravel drainage zone and corefill (see *Figure E:3, below*) allows proper drainage under most circumstances. Drain tiles should be routed to a storm drainage system or daylighted below or through the wall at every low point and/or 30 to 50-feet on center.
- 2. Surface run-off:** To reduce infiltration of surface drainage at the top of the retaining wall, place an 8-inch low permeable soil cap (i.e. clay) above the reinforced soil and drainage fill areas. The upper 8-inch low impermeable soil should be graded to flush with the top of cap elevation (see *Figure E:3, below*).
- 3. Drainage swale:** Some engineers and DOTs prefer a drainage swale at the top of the wall. To allow drainage down the swale, drainage swales can only be installed on walls that have one high point and the wall tapers down in elevation from that high point to the ends of the wall. SRWs tend to move slightly with time. To accommodate some movement, drainage swales should be constructed with relatively impermeable soil (clay) or asphalt. Drainage swales constructed with concrete tend to crack over time, either at the joints or elsewhere, or become separated from the expansion material between the swale and cap units. If a concrete swale must be installed, regular maintenance of any separations, cracks or joints should be anticipated (see *Figure E:4, page 51*).
- 4. Embankment flow:** When embankment ground water flow behind the wall is likely, place a drainage composite or chimney drain vertically against cut soil (see product suppliers for recommended coverage and installation instructions or drainage composite). The drainage composite or chimney drain should drain to an outflow pipe (i.e. drain tile) to remove water. Numerous cost-effective products are available to serve this purpose (see *Figure E:3, below*).
- 5. Ground water flow:** The effects of seasonally fluctuating ground water at the base of the retaining wall can be offset by placing a blanket drain along the base of the reinforced zone (see *Figure E:3, below*).

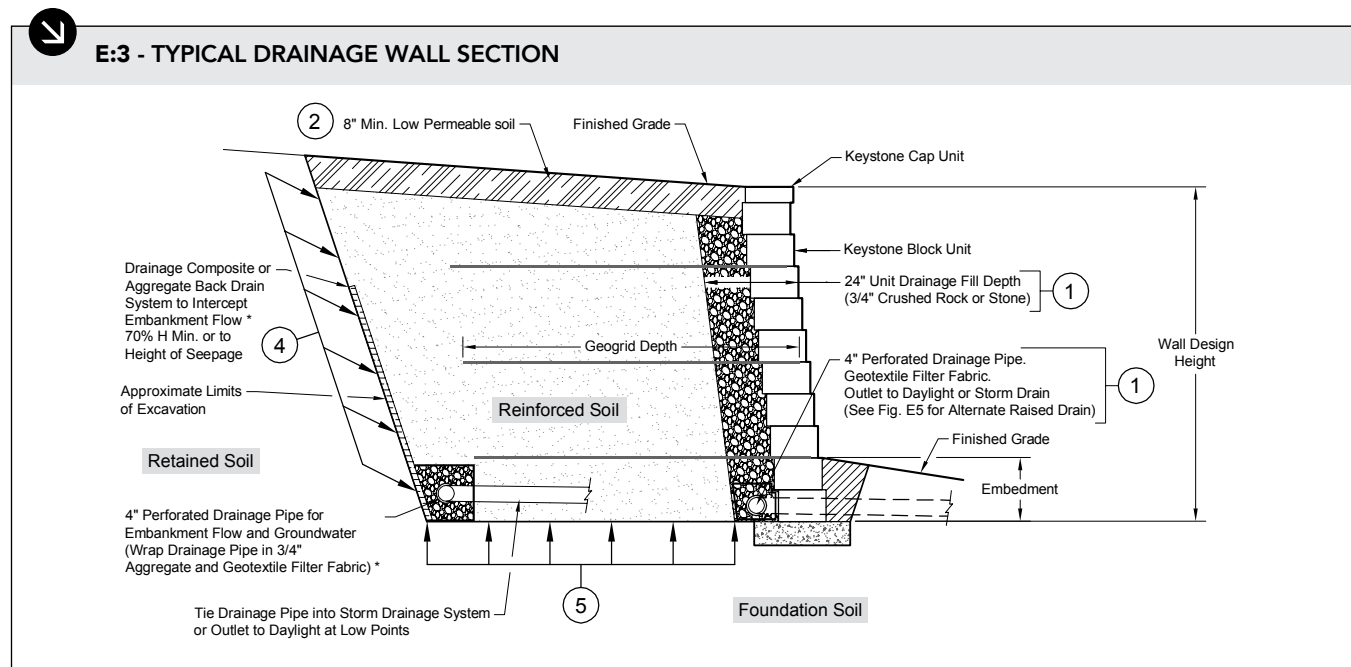

NOTES:

- Rear drainage pipe should be included when: groundwater or seepage is present in retained soils; springs or seasonal seepage potential is noted in geotechnical report; reinforced soil is of lower permeability than retained soils.
- Generally, additional drainage material such as aggregate drains and fabrics and/or drainage composite boards are used in conjunction with a rear drainage pipe, as directed. When above conditions are not present or groundwater conditions are not a factor, the rear drainage pipe may be omitted.
- When required, size, location and specific drainage materials should be completed as directed by the site geotechnical engineer.

The information contained herein has been compiled by Keystone Retaining Wall Systems® LLC and to the best of our knowledge, accurately represents the Keystone product used in the applications which are illustrated. Final determination of the suitability for the use contemplated and its manner of use are the sole responsibility of the user. Design and analysis shall be performed by a qualified engineer.

Retaining Wall Drainage Options



E:4 - TYPICAL DRAINAGE/SWALE WALL SECTION

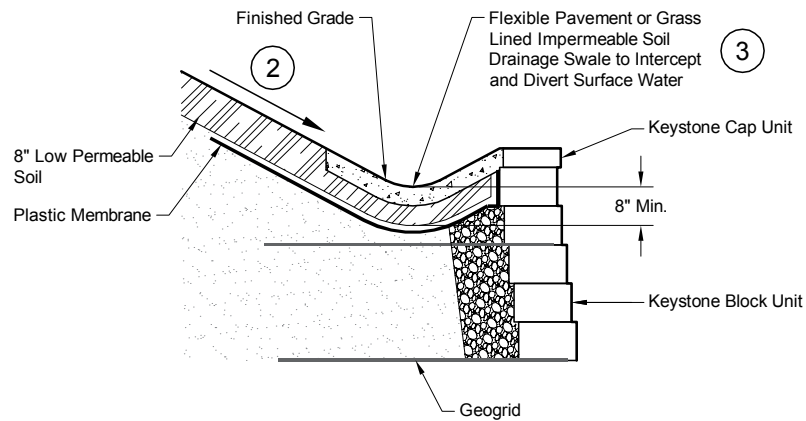

E:5 - ALTERNATE RAISED DRAINAGE PIPE LOCATIONS

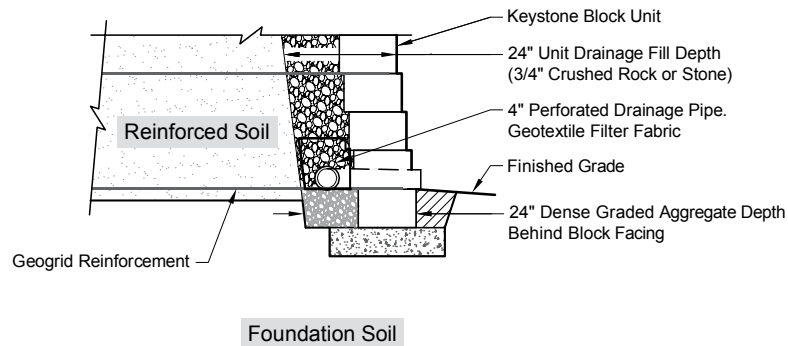

NOTES:

- Alternate raised drain pipe locations may only be used when (see Figure E:5, above):
 - The grade in front of the wall is flat and does not allow for gravity outlet of a pipe below the wall or through the base course of block.
 - There is no storm sewer system to outlet pipe directly into.
- Alternate locations are only used when site geometry requires drain pipe to be raised in order to outlet at face.

Storm Drain Outlet

Placement of storm drain outlets through the wall face are a common application. Since it is not possible to cut the block in a curve to fit tightly around the pipe, it is recommended that a cast-in-place collar be built around the pipe. The wall units can then be cut to the appropriate length and butted closely to the sides of the collar. Care should be taken to position the top of the collar within $\frac{1}{2}$ - 1-inch (13mm to 25mm) below the horizontal joint of the block above. This action will allow placement of the next course of units onto a wet set mortar bed to achieve horizontal wall alignment.

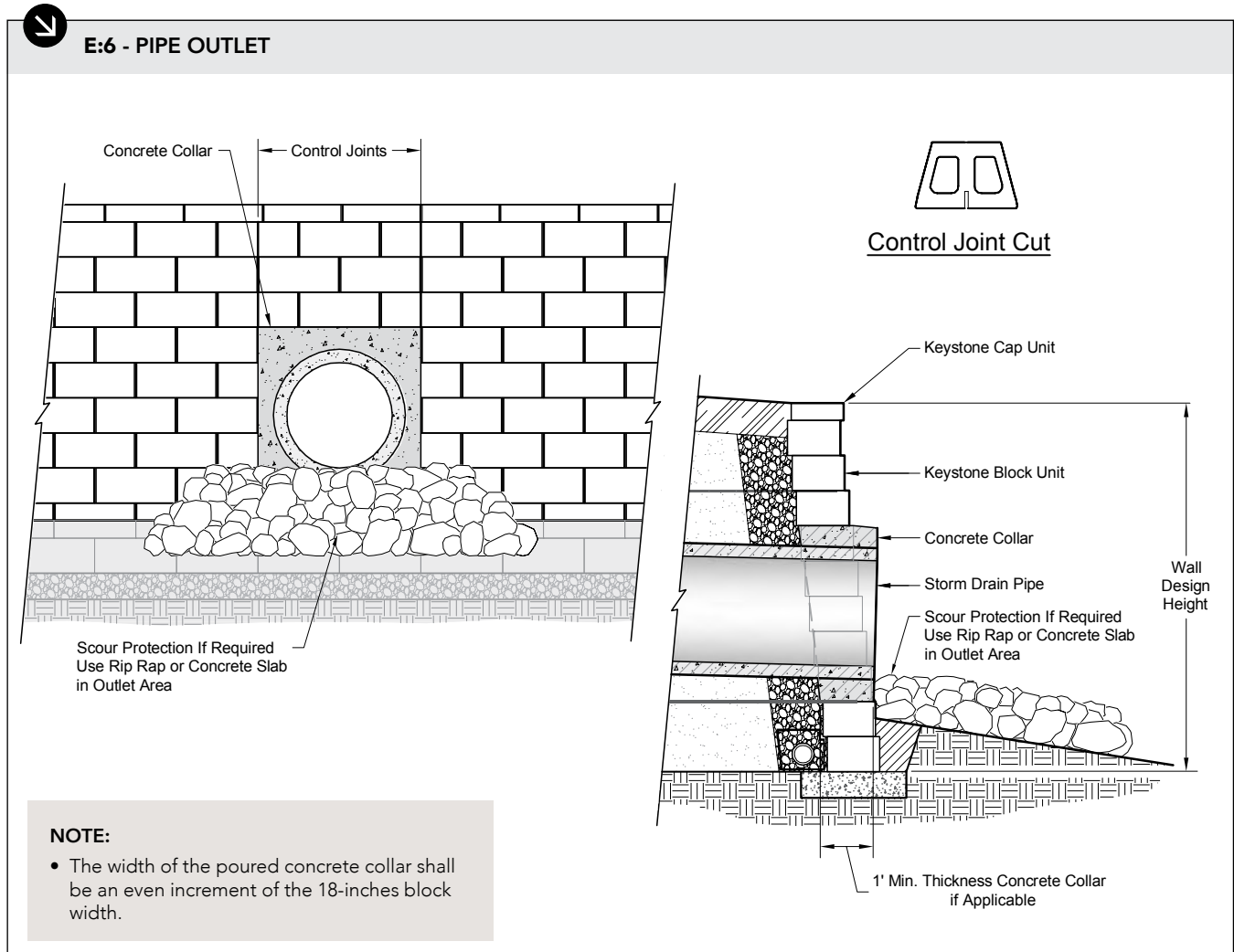

NOTES:

- A "control joint" should be constructed from the top of a concrete collar to the top of the wall. This control joint consists of saw-cutting a joint, from the face of the block back 3.5-inches minimum at the midpoint of the units on every other course.
- Provide splash block, concrete gutter or rip-rap for storm drain pipe outlet for scour protection, as required.

The information contained herein has been compiled by Keystone Retaining Wall Systems® LLC and to the best of our knowledge, accurately represents the Keystone product used in the applications which are illustrated. Final determination of the suitability for the use contemplated and its manner of use are the sole responsibility of the user. Design and analysis shall be performed by a qualified engineer.

Barriers: Introduction

Keystone walls can readily be installed with many types of barrier systems. There are two main types of barriers: pedestrian fall protection devices and vehicular barriers.

Pedestrian fall protection devices come in various forms such as railings and fences. Most public design codes require some form of fall protection when a retaining wall reaches a specified height. Please contact your local building officials for code requirements in your area to determine if and when a fall protection device is required for your retaining wall. Keystone recommends fall protection be installed for all walls over 3-feet in height.

In general, vehicular barrier systems typically fall into two categories, flexible guide rails and rigid impact barriers. Flexible guide rails are the most common traffic device due to the simplicity of installation and the fact that they are typically more cost effective than a rigid option.

When a flexible guide rail is not an option, typically due to traffic type or insufficient room, often times a rigid cast-in-place (CIP) concrete traffic barrier is the next best solution. CIP concrete traffic barriers are most commonly used in DOT applications, but can also be specified in private application roadways with heavy traffic areas. CIP concrete traffic barriers can vary greatly by the application type, location, or design codes. Refer to state DOT agencies for specific details related to traffic barriers and MSE walls.

Guide Rails

When installing a guide rail with a Keystone wall, there are three important guidelines that must be met as mandated by The American Association of State Highway Transportation Officials (AASHTO).

1. The guide rail must be located a minimum of 3-feet from wall face.
2. The guide rail post shall be placed a minimum 5-feet into the ground.
3. The guide rail shall extend through a minimum of 2 geogrid layers.

There are a number of installation methods for a guide rail with a Keystone wall. Always reference the project-engineered drawings for the preferred installation method.

1. Preferred method: sleeves can be installed during construction to allow for the placement of guiderail foundation posts after wall construction.
2. Steel posts can be driven into the ground after wall construction. Care should be taken to ensure that a sufficient depth of compacted soil is in place above the upper layer of geogrid prior to driving any post systems. Displaced wall units or geogrid reinforcement should be repaired.

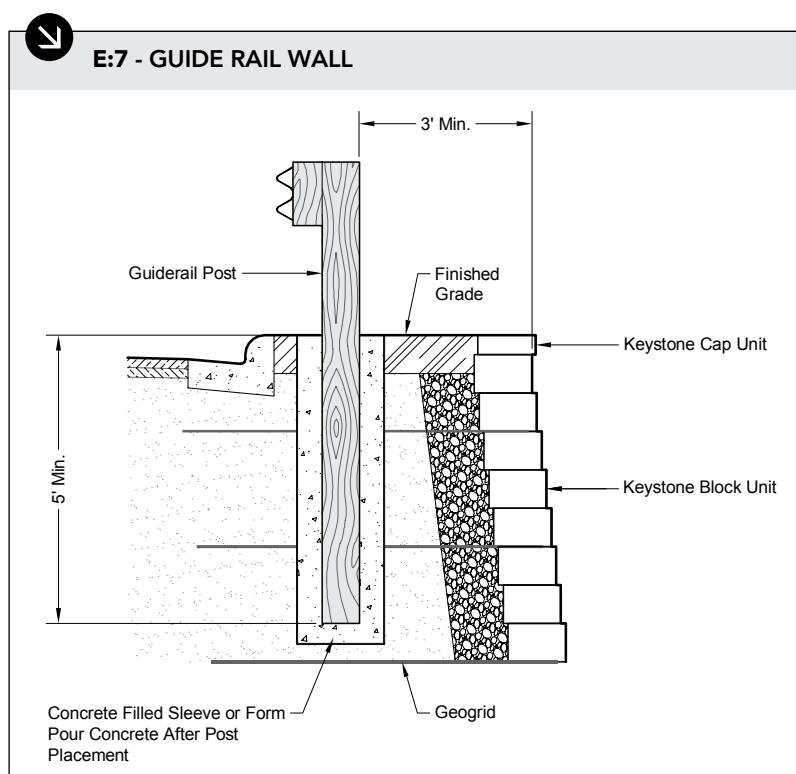

Barriers: Fencing Options

Fences can be placed at the top of a Keystone wall with fence posts placed behind the Keystone units. The choice, location, and compliance with local codes of the appropriate fall protection system, is the responsibility of the owner and site engineer. Follow these procedures for proper installation of fence posts with Keystone walls.

1. Install the Keystone wall per general installation instructions.
2. Fence posts positioned behind the Keystone units may be installed and anchored using a variety of installation methods.

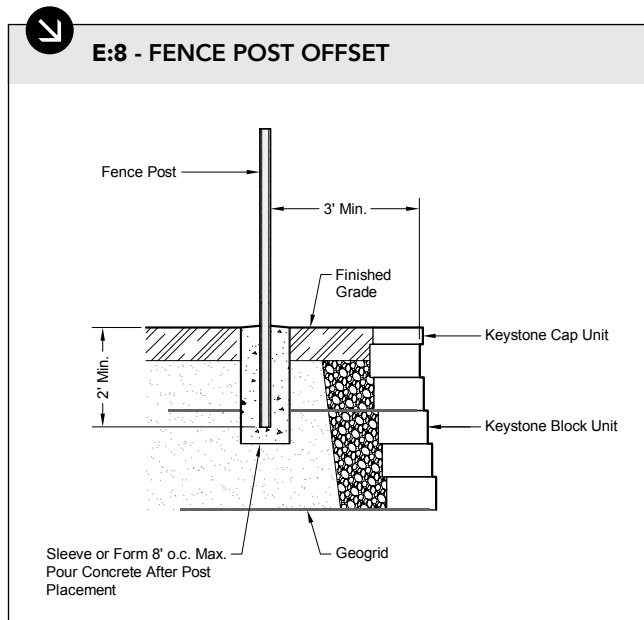

E:8

- Fence post placed at least 3-feet behind wall face shall extend a minimum 2-feet in the ground.

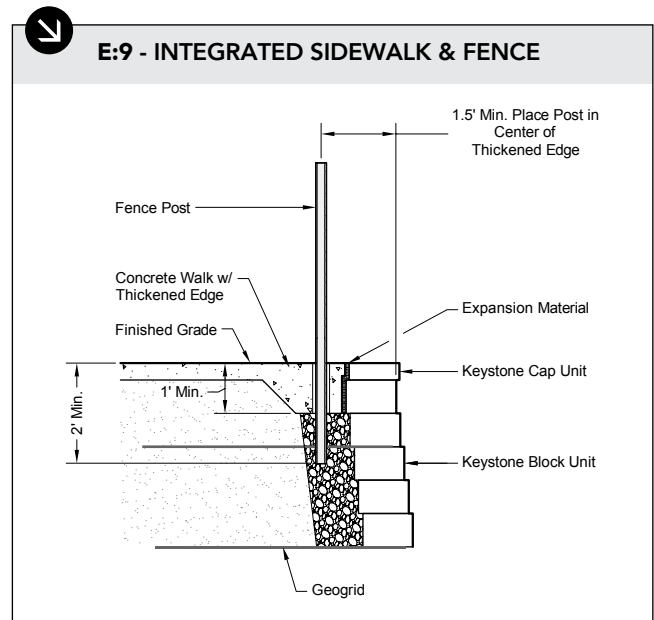

E:10 - FENCE MINIMUM OFFSET

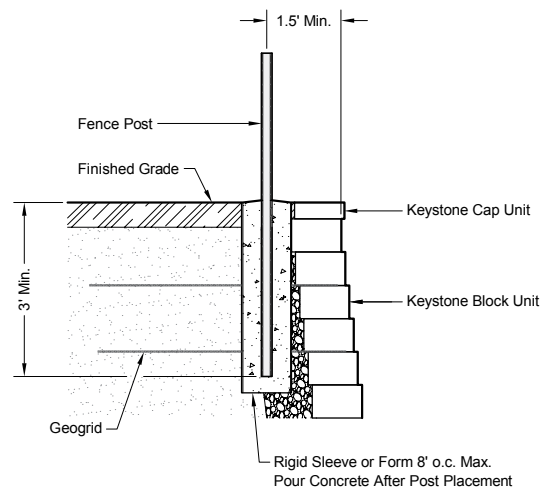

Terraced Wall Application

Terraced Keystone walls can provide a visually appealing solution to grade change. Slope conditions below, between and above the walls, soil conditions, and the horizontal distance between the walls will impact terraced wall design. In many cases, the geogrid lengths of the lower wall will be longer than typical to satisfy stability requirements. Always consult a qualified design professional for assistance with terraced walls.

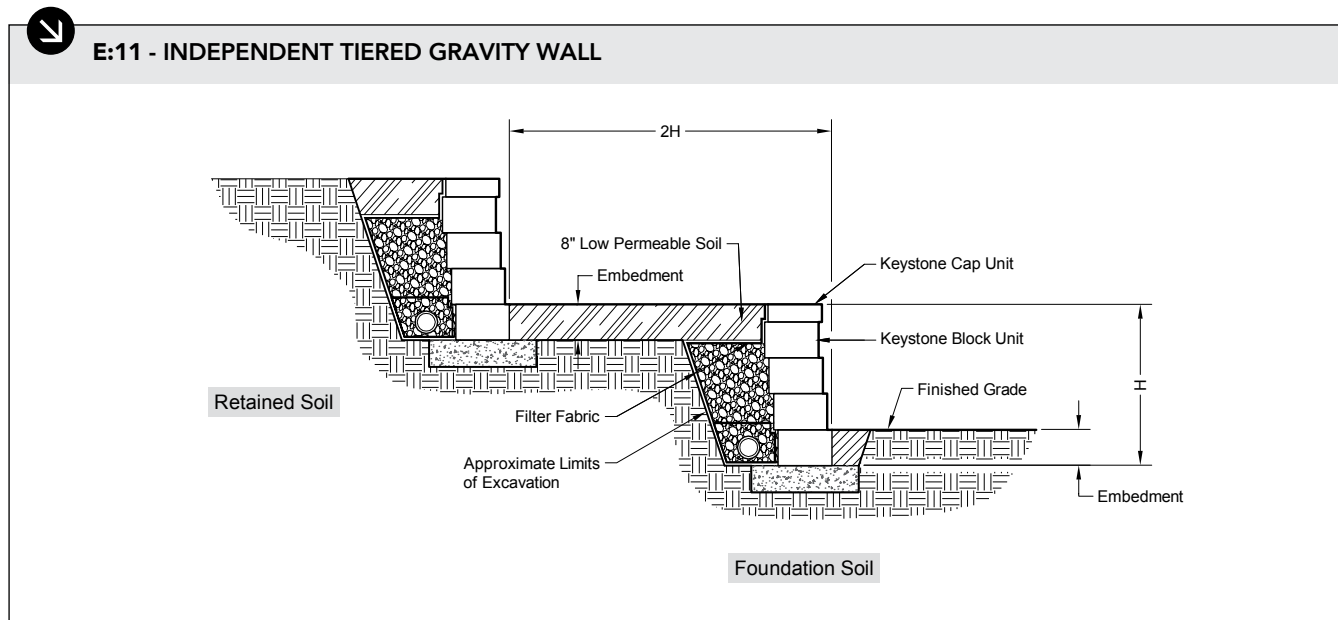

NOTES:

- For gravity wall designs and for individual walls to behave independently of each other, the horizontal distance between walls must be at least $(2H)$, 2 x design height of the lower wall. If the distance between the walls is less than 2 x design height of the lower wall, the lower wall must be designed with upper wall loading consideration. Always consult with a qualified engineer for geogrid reinforced and tiered wall designs. Lower wall height must be greater than upper wall height. All grades around all walls must be level. If the $2H$ rule does not apply, the walls dependent on each other and geogrid reinforcement will be required. (see *Figure E:12, below*)
- Railing or fall protection, as per local codes.

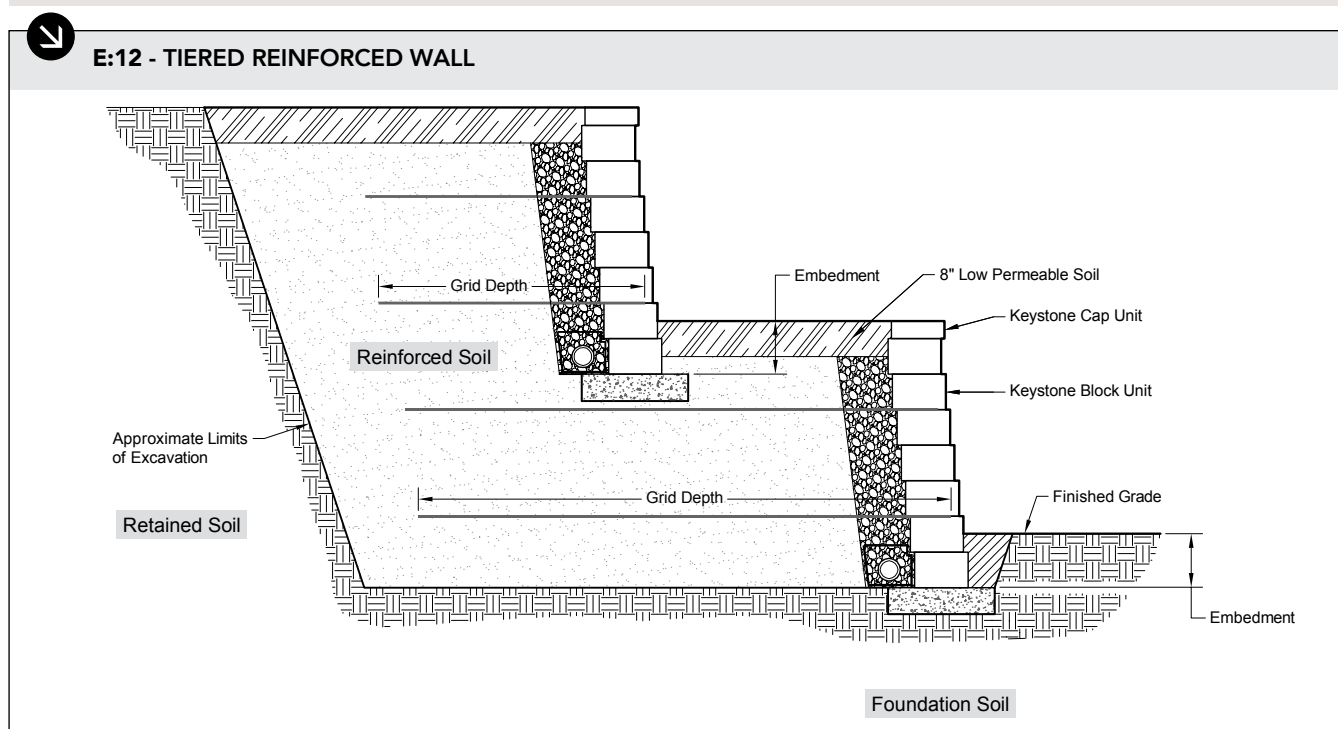

The information contained herein has been compiled by Keystone Retaining Wall Systems® LLC and to the best of our knowledge, accurately represents the Keystone product used in the applications which are illustrated. Final determination of the suitability for the use contemplated and its manner of use are the sole responsibility of the user. Design and analysis shall be performed by a qualified engineer.

Planting Guidelines



E:13 - PLANTING LIMITS BEHIND WALL

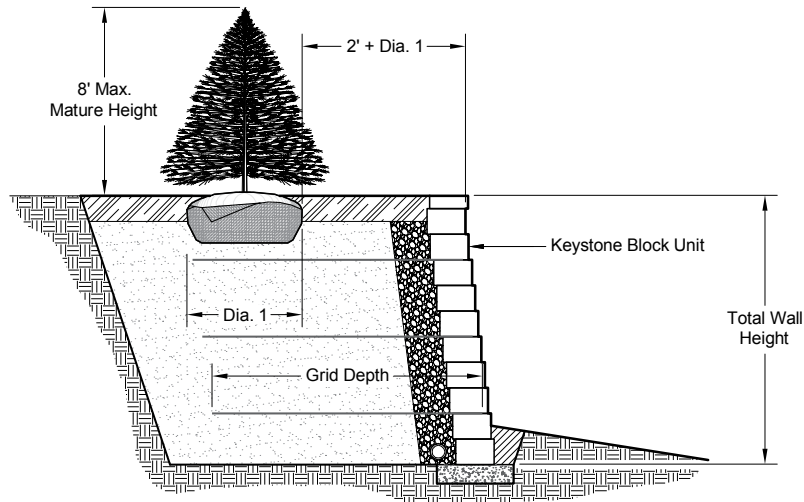

Planting

1. Only the top layer of the geogrid may be cut to allow planting of tree ball. Avoid disturbance of adjacent reinforcement. Mature tree height should not exceed 8 feet.
2. Extreme care should be taken if installing irrigation systems directly behind the wall so as to not damage the soil reinforcement during installation or have potential leakage into the retaining wall system. Leaking irrigation lines can saturate the backfill and create hydrostatic pressure and wall movement.
3. Utilize a root control barrier as required to avoid pressures or growth through the Keystone block units.
4. Numbers in parenthesis are for example only.



E:14 - PLANTING LIMITS BEHIND WALL

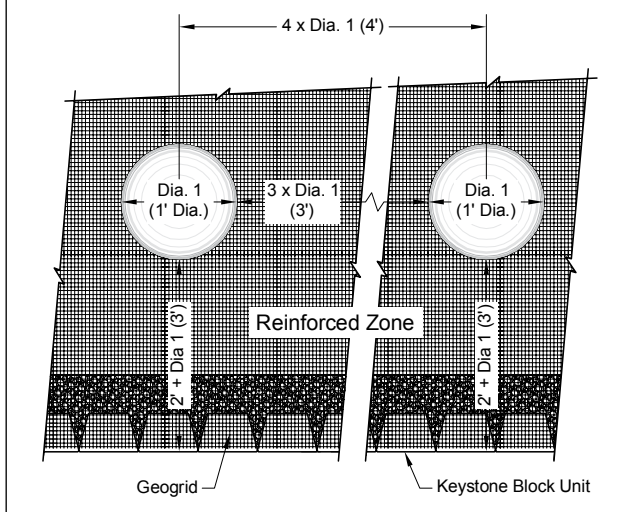

NOTES:

- All planting offsets shall be a minimum of 2-feet plus the root ball opening diameter as measured from the face of the wall.
- Lateral spacing between the openings shall be a minimum of 3 x the largest opening diameter.
- If trees are placed closely together and cutting of geogrid becomes excessive, consult with your wall design engineer or Keystone representative.

The information contained herein has been compiled by Keystone Retaining Wall Systems® LLC and to the best of our knowledge, accurately represents the Keystone product used in the applications which are illustrated. Final determination of the suitability for the use contemplated and its manner of use are the sole responsibility of the user. Design and analysis shall be performed by a qualified engineer.